

# SCS

# PTC-IIpro

**The New Dimension in Data Transmission Technology**

Manual for Version 3.6

© Copyright 2001-2005 **SCS** GmbH & Co. KG

---

## Disclaimer

**SCS** makes no representation of warranties with respect to the contents hereof and specifically disclaims any implied warranties of merchantability or fitness for any particular purpose. Further, **SCS** reserves the right to revise this publication, hardware, and software, and to make changes from time to time in the content thereof without the obligation of **SCS** to notify any persons of such revisions or changes.

## Foreword

The information contained in this handbook has been carefully put together. It is, however, still possible that errors have crept in. If any errors are found, we ask your forgiveness, and request you send us a short note pointing them out.

Your **SCS**-Team

## Attention, Very Important:

You should connect the power supply plug to the PTC-IIpro only when the power supply is switched off. First connect the plug to the PTC-IIpro, and then to the power supply.

The DC plug of the PTC-IIpro should never be plugged into its socket with the power connected. This applies especially when the PTC-IIpro and the radio equipment are connected by means of the AF and the PTT cables, and use the same power supply.

The case of the PTC-IIpro is at earth potential, and, in event of a short circuit, very serious internal damage to the PTC-IIpro can occur if this advice is not followed.

Manual rev. F

PACTOR™ is a registered trademark of **SCS** GmbH & Co. KG, Hanau, GERMANY.

---

**Special Communications Systems Model PTC-IIpro**  
**Federal Communications Commission (FCC) Statement**

This equipment has been tested by a FCC accredited testing facility and found to comply with the limits for Class B Digital Device, pursuant to Part 15 of the FCC rules. These rules are designed to provide reasonable protection against harmful interference in a residential installation.

Operation is subject to the following two conditions: 1) This device may not cause harmful interference, and 2) this device must accept any interference received including interference that may cause undesired operation.

This device is exempt from these rules in any transportation vehicle including motor vehicle and aircraft as per Part 15.103 (a).

Any changes or modifications to this equipment may void the users authority to operate this equipment.

For further information, please contact:

Farallon Electronics  
2346 B Marinship Way  
Sausalito, CA 94965 U.S.A.  
+415 331 1924  
+415 331 2063 fax  
[pactor@farallon.us](mailto:pactor@farallon.us)  
<http://www.farallon.us/>

## Table of Contents

<b>1</b>	<b>Introduction.....</b>	<b>1</b>
1.1	SCS-PTC, the Original.....	1
1.2	Requirements .....	1
1.3	About this manual.....	1
1.3.1	Typography .....	2
1.4	HF-email.....	2
1.5	The SCS CD-ROM .....	2
1.5.1	The programs .....	3
1.5.2	Version numbering .....	5
1.5.3	File types .....	5
1.6	Professional solutions.....	5
1.6.1	PACTOR-III .....	6
1.6.2	PACTOR-IP-Bridge .....	7
1.6.3	EasyTransfer .....	7
<b>2</b>	<b>Customer Support .....</b>	<b>9</b>
2.1	If you have a problem .....	10
<b>3</b>	<b>Installation .....</b>	<b>11</b>
3.1	Power supply .....	11
3.2	The serial interface (RS232/V24) .....	11
3.3	Connections to the transceiver .....	12
3.3.1	Connection to ICOM transceivers:.....	15
3.3.2	Connection to Kenwood transceivers: .....	15
3.3.3	Connection to Yaesu transceivers:.....	16
3.3.4	Amplitude Adjustment.....	17
3.4	Transceiver Remote Control.....	18
3.4.1	Connections PTC - KENWOOD .....	20
3.4.2	Connections PTC - ICOM.....	21
3.4.3	Connections PTC - YAESU .....	21
3.5	The Packet-Radio Modules .....	23
3.5.1	Installation .....	23
3.5.2	The DSP-Module-II.....	23
3.5.3	The DSP-Module .....	25
3.5.4	The AFSK Module .....	28
3.5.5	The 9k6-Module.....	29
3.5.6	The Packet-Radio connectors .....	31
<b>4</b>	<b>LED's .....</b>	<b>33</b>
<b>5</b>	<b>PTC-Firmware .....</b>	<b>37</b>
5.1	General.....	37
5.2	Command structure .....	38
5.3	Menus.....	38

## Table of Contents

---

5.4	Simultaneous STBY mode .....	39
5.5	Remote commands .....	39
5.6	PTC-Mailbox .....	40
5.6.1	Multiple file operations .....	42
5.6.2	Special features when reading files.....	42
5.6.3	The PTC mailbox for Packet-Radio.....	42
5.6.4	Practical operation using the PR mailbox.....	43
5.6.5	Passing PR connects to the mailbox.....	45
5.6.6	Properties of mailbox-commands.....	45
5.7	The NAVTEX-Processor .....	45
5.7.1	NAVTEX General.....	45
5.7.2	The NAVTEX System in Detail.....	46
5.7.3	Operating the NAVTEX Processor.....	47
5.7.4	Notes about NAVTEX practice .....	48
5.7.5	AMTEX.....	48
5.8	GPS .....	49
5.8.1	Connecting the GPS receiver.....	49
5.8.2	GPS position request .....	49
5.9	APRS .....	50
5.10	Robust HF-Packet.....	50
5.11	The PR →PACTOR Gateway .....	51
5.11.1	TRX command .....	52
5.11.2	Gate command.....	52
5.11.3	CHANGEOVER problems.....	54
5.12	PACTOR Duplex and PACTOR data transparency.....	55
5.12.1	Application for PACTOR Duplex .....	56
5.12.2	How to avoid incompatibility?.....	56
5.12.3	PACTOR data transparency .....	57
5.13	Audio Functions .....	57
5.14	The hostmode .....	58
<b>6</b>	<b>Commands.....</b>	<b>61</b>
6.1	ACheck (AMTOR Check) .....	61
6.2	ADdlf .....	61
6.3	Amtor .....	61
6.4	APower .....	62
6.5	AQrg.....	63
6.6	ARX.....	63
6.7	AUdio .....	64
6.8	BAKup.....	64
6.9	BAUdot.....	65
6.10	BC .....	66
6.11	BEll <small>Remote</small> .....	66
6.12	BKchr .....	66
6.13	BMsg.....	67
6.14	BOOT .....	67
6.15	Box.....	67

## Table of Contents

---

6.16	BRightn.....	68
6.17	CHeck Remote .....	68
6.18	CHOBell .....	68
6.19	CHOchr .....	69
6.20	CLr Remote .....	69
6.21	CMsg .....	69
6.22	Connect .....	70
6.22.1	Longpath-connect.....	70
6.22.2	Robust-connect .....	70
6.22.3	AMTOR .....	71
6.22.4	Direct frequency entry .....	71
6.22.5	FlexNet-Style PACTOR→PACKET-Gateway .....	72
6.23	CONType .....	73
6.24	CSDelay Remote .....	73
6.25	CTExt .....	73
6.26	CTrlchr.....	74
6.27	CWid.....	74
6.28	CWMoni.....	75
6.29	CWSpeed.....	75
6.30	CWTerm .....	75
6.31	CWWeight .....	77
6.32	CYcle.....	78
6.33	DAte Remote .....	78
6.34	DD .....	78
6.35	DElete Remote .....	78
6.36	DIR Remote .....	79
6.37	Disconnect.....	80
6.38	EQualize.....	80
6.39	ESCchr .....	80
6.40	FAX .....	80
6.41	FEc.....	81
6.42	FSKAmpl .....	81
6.43	Gate Remote .....	82
6.44	HCr .....	83
6.45	Help Remote.....	83
6.46	LFignore .....	83
6.47	LICENSE .....	84
6.48	LIN.....	84
6.49	Llst Remote .....	84
6.50	Listen.....	85
6.50.1	PACTOR-III .....	85
6.51	LOCK .....	86
6.52	LOg Remote .....	86
6.53	LOGIn Remote.....	86
6.54	MAil .....	87
6.55	MARK.....	87
6.56	MAXDown .....	87

## Table of Contents

---

6.57	MAXErr .....	88
6.58	MAXSum .....	88
6.59	MAXTry .....	88
6.60	MAXUp .....	88
6.61	MOde .....	89
6.62	MONitor .....	90
6.63	MYcall .....	90
6.64	MYLevel .....	91
6.65	MYSelc .....	91
6.66	NAVtex .....	91
6.66.1	Activating the NAVTEX Processor .....	92
6.66.2	Setting the types of messages required .....	92
6.66.3	Choice of the message area codes .....	92
6.66.4	Choosing the message latency time .....	93
6.66.5	AMTEX .....	93
6.67	NULI .....	94
6.68	OFF .....	95
6.69	PACKet .....	95
6.70	PDTimer .....	96
6.71	PDuplex .....	96
6.72	Phase <small>Remote</small> .....	96
6.73	POSition <small>Remote</small> .....	97
6.74	PSKAmpI .....	97
6.75	PSKTerm .....	98
6.76	PT .....	98
6.77	PTChn .....	98
6.78	Qrt <small>Remote</small> .....	98
6.79	QRTChr .....	99
6.80	Read <small>Remote</small> .....	99
6.81	RELOad .....	99
6.82	REMote .....	100
6.83	RESEt <small>Remote</small> .....	100
6.84	RESTart .....	101
6.85	RLe .....	101
6.86	Send <small>Remote</small> .....	101
6.87	SERBaud .....	101
6.88	SFile .....	102
6.89	SHow <small>Remote</small> .....	102
6.90	SPAce .....	103
6.91	SQuelch .....	103
6.92	STatus .....	104
6.93	SYStest .....	106
6.94	Term .....	107
6.95	Tlme <small>Remote</small> .....	109
6.96	TNC .....	109
6.97	TOnes .....	110
6.98	TR .....	112

## Table of Contents

---

6.99	TRX <small>Remote</small> .....	112
6.100	TXDelay .....	112
6.101	Umlauts .....	113
6.102	Unproto .....	113
6.103	UPDATE .....	114
6.104	USer <small>Remote</small> .....	115
6.105	USOs (Unshift On Space) .....	115
6.106	VERIfy .....	115
6.107	Version <small>Remote</small> .....	115
6.108	Write <small>Remote</small> .....	115
6.109	XUser .....	116
<b>7</b>	<b>Audio .....</b>	<b>119</b>
7.1	Bandwidth .....	119
7.2	Center .....	119
7.3	CWfilter .....	119
7.4	DD .....	120
7.5	Delay .....	120
7.6	Help .....	120
7.7	Invert .....	120
7.8	Level .....	120
7.9	Notch .....	120
7.10	Peak .....	121
7.11	Quit .....	121
7.12	Through .....	121
7.13	TOne .....	121
<b>8</b>	<b>FAX .....</b>	<b>123</b>
8.1	General Information .....	123
8.2	Basic info concerning FAX and SSTV .....	123
8.2.1	AM-FAX .....	123
8.2.2	FM-FAX .....	124
8.2.3	SSTV .....	125
8.3	FAX and SSTV with JVComm32 .....	126
8.3.1	Specifications .....	126
8.3.2	Reference of databytes concerning the PTC .....	127
8.3.3	LED functions .....	127
8.4	Fax:-menu commands .....	128
8.5	The PTC-IIpro as COMPARATOR-MODEM .....	129
8.6	MODEM commands in detail .....	129
8.6.1	Amfax .....	129
8.6.2	Fmfax .....	130
8.6.3	Sstv .....	130
8.6.4	Jvfax .....	131
8.6.5	JVComm .....	132
8.6.6	FSK .....	132
8.6.7	Comparator .....	133
8.6.8	PTC-IIpro with 300 baud HF Packet .....	133

## Table of Contents

---

8.7	Transmission during MODEM operation .....	134
8.7.1	Transmission in AM-FAX-Modem mode .....	134
8.7.2	Transmission in FM-FAX/FSK/SSTV-Modem mode ..	134
8.7.3	Transmission in COMPARATOR mode .....	135
8.8	The Parameter commands in detail .....	135
8.8.1	AGain .....	135
8.8.2	AResolut .....	136
8.8.3	FResolut.....	136
8.8.4	SResolut .....	136
8.8.5	FSKBaud.....	136
8.8.6	Deviation .....	137
8.8.7	MBaud.....	137
8.8.8	HSynch .....	137
8.8.9	JSynch .....	138
8.8.10	SMode.....	138
8.8.11	TXcomp.....	139
8.9	LED functions and matrix-display.....	140
8.9.1	The LED's whilst receiving.....	140
8.9.2	The LED's whilst transmitting.....	140
8.9.3	Information in the Matrix Display .....	140
8.9.4	Tuning- and LED display in COMPARATOR mode...	140
8.9.5	LED's in PR300 operation .....	141
8.10	Tips and Tricks .....	141
8.10.1	IF-SHIFT .....	141
8.10.2	Tuning with SSTV .....	141
<b>9</b>	<b>Packet-Radio .....</b>	<b>143</b>
9.1	DAMA.....	143
9.2	Packet-Radio-modules.....	143
9.2.1	The SCS-DSP-Module-II .....	143
9.2.2	Additional-Modules.....	146
9.3	External modems .....	146
9.4	Port & Channel.....	149
9.5	Modern Times .....	150
9.6	Commands.....	150
9.6.1	Aprs.....	150
9.6.2	Baud.....	154
9.6.3	CBell .....	154
9.6.4	CHeck .....	155
9.6.5	CMsg.....	155
9.6.6	Connect.....	155
9.6.7	CONStamp.....	156
9.6.8	CONVerse.....	156
9.6.9	CStatus .....	156
9.6.10	CText .....	156
9.6.11	DIGIpeat.....	157
9.6.12	Disconnect .....	157

## Table of Contents

---

9.6.13	FRack .....	157
9.6.14	FSKFilter .....	158
9.6.15	FUlldup .....	158
9.6.16	Help .....	158
9.6.17	JHOST .....	158
9.6.18	MAXframe .....	159
9.6.19	MCon .....	159
9.6.20	MFilter .....	159
9.6.21	Monitor .....	160
9.6.22	MStamp .....	160
9.6.23	MText .....	160
9.6.24	MYAlias .....	161
9.6.25	MYcall .....	161
9.6.26	MYMail .....	162
9.6.27	PACLen .....	162
9.6.28	PErsist .....	162
9.6.29	Port .....	163
9.6.30	PRBox .....	163
9.6.31	Quit .....	163
9.6.32	RESptime .....	163
9.6.33	REtry .....	163
9.6.34	Setchn .....	164
9.6.35	SLottime .....	164
9.6.36	TRACE .....	164
9.6.37	TXdelay .....	164
9.6.38	TXLevel .....	165
9.6.39	Unproto .....	166
9.6.40	USers .....	166
<b>10</b>	<b>Hostmode .....</b>	<b>167</b>
10.1	The PTC-IIpro hostmode .....	167
10.2	Modern Times .....	168
10.3	DAMA .....	169
10.4	Commands .....	169
10.4.1	C .....	170
10.4.2	D .....	171
10.4.3	F .....	171
10.4.4	G .....	171
10.4.5	I .....	171
10.4.6	JHOST .....	172
10.4.7	K .....	172
10.4.8	L .....	172
10.4.9	M .....	172
10.4.10	N .....	173
10.4.11	O .....	173
10.4.12	P .....	173
10.4.13	PS .....	173

## Table of Contents

---

10.4.14	T.....	173
10.4.15	U.....	174
10.4.16	V.....	174
10.4.17	W.....	174
10.4.18	Y.....	174
10.4.19	@B.....	175
10.4.20	@D.....	175
10.4.21	@F.....	175
10.4.22	@S.....	177
10.4.23	@T2.....	177
10.4.24	@T3.....	177
10.4.25	%B.....	177
10.4.26	%C.....	178
10.4.27	%E.....	178
10.4.28	%F.....	178
10.4.29	%I.....	178
10.4.30	%L.....	179
10.4.31	%M.....	179
10.4.32	%O.....	179
10.4.33	%P.....	180
10.4.34	%T.....	180
10.4.35	%V.....	180
10.4.36	%W.....	180
10.5	Extended hostmode.....	182
10.6	Status output in hostmode.....	182
10.6.1	Auto status in hostmode.....	183
10.7	TRX Control Channel on Hostmode.....	183
10.8	NMEA-Channel.....	184
10.9	CRC hostmode.....	184
10.9.1	Basic principles.....	185
10.9.2	MASTER protocol.....	186
10.9.3	SLAVE-protocol.....	186
10.9.4	Stuffing errors or unexpected header sequences.....	187
10.9.5	Start of the CRC-hostmode.....	187
10.9.6	Recommended baudrate.....	188
10.9.7	Example source code for CCITT CRC16 (HDLC).....	188
<b>11</b>	<b>PSK31.....</b>	<b>191</b>
11.1	General.....	191
11.2	Activation and use of the PSK31 terminal.....	191
11.3	Carrier Frequencies.....	192
11.4	Level Setting.....	192
11.5	Prompt and Status.....	192
11.6	Hot-keys.....	192
11.7	Receiver Tuning.....	194
11.8	CW-Identification.....	194

## Table of Contents

---

<b>12</b>	<b>SYStest</b> .....	<b>195</b>
12.1	Audio .....	195
12.2	AUDPerm .....	195
12.3	BATtery .....	196
12.4	Beep .....	196
12.5	DD .....	196
12.6	Down .....	196
12.7	Fsk.....	196
12.8	Help.....	196
12.9	Kill.....	197
12.10	Led .....	197
12.11	MONitor .....	197
12.12	Ptt.....	197
12.13	PLI .....	197
12.14	Ram.....	198
12.15	SERNum .....	198
12.16	Up.....	198
12.17	Quit.....	198
12.18	Trxtest .....	198
<b>13</b>	<b>TRX</b> .....	<b>199</b>
13.1	Channel .....	199
13.2	DD .....	200
13.3	Down .....	201
13.4	DUmp .....	201
13.5	DWell.....	203
13.6	Frequency .....	203
13.7	Help.....	204
13.8	List (remotable as command TRX List) .....	204
13.9	Offset.....	204
13.10	Parity .....	204
13.11	Ptime .....	205
13.12	Quit.....	205
13.13	RType .....	205
13.14	Scan .....	205
13.15	Tlmer .....	206
13.16	Transfer .....	206
13.17	TType.....	207
13.18	Up.....	208
13.19	Wait .....	209
13.20	XGate .....	209
13.21	XScan.....	209
13.22	YType .....	210
13.23	External scan stop signal.....	210
13.24	Special Features.....	210
13.24.1	Direct Channel Selection for YAESU Transceivers ..	210
13.25	Channel attributes .....	211

## Table of Contents

---

13.25.1	Preamp switching at R&S XK-2000 Transceiver .....	211
13.25.2	Controlling the Antenna Switch .....	211
13.25.3	Timer Attributes .....	212
13.25.4	Hex Attribute .....	213
13.25.5	Level Attribute .....	213
13.26	TRX Control Channel on Hostmode .....	213
<b>14</b>	<b>The BIOS .....</b>	<b>215</b>
14.1	BIOS and Firmware .....	215
14.2	Activating the BIOS .....	216
14.3	BIOS commands .....	216
14.3.1	DAtE .....	216
14.3.2	FCall .....	217
14.3.3	FSelcall .....	217
14.3.4	Help .....	217
14.3.5	OFF .....	217
14.3.6	SERBaud .....	218
14.3.7	SYStest .....	218
14.3.8	Time .....	218
14.3.9	UPDATE .....	219
14.3.10	Version .....	219
14.4	BIOS SYStest commands .....	219
14.4.1	BATtery .....	219
14.4.2	Beep .....	219
14.4.3	CFg .....	219
14.4.4	CHKFlash .....	219
14.4.5	CHKRam .....	219
14.4.6	CLr .....	219
14.4.7	Help .....	219
14.4.8	Led .....	220
14.4.9	Quit .....	220
14.4.10	RAMCLR .....	220
14.4.11	RTCTrim .....	220
14.4.12	RUN .....	220
14.4.13	SERNum .....	220
14.4.14	Trxtest .....	220
<b>15</b>	<b>Circuit Description .....</b>	<b>221</b>
15.1	The Processor section .....	221
15.2	The shortwave modem with signal processor .....	223
15.3	The Power supply .....	225
15.4	The display and indicator unit .....	226
15.5	The Packet-Radio ports .....	226
15.6	The Construction .....	226
<b>16</b>	<b>Basics .....</b>	<b>229</b>
16.1	Why PACTOR? .....	229
16.2	Why PACTOR-II ? .....	230

## Table of Contents

---

16.3	Basics of the PACTOR-II protocol .....	231
16.3.1	General .....	231
16.3.2	The modulation system .....	232
16.3.3	Error control coding .....	235
16.3.4	Online data compression .....	236
16.4	PACTOR-II in practice .....	237
16.4.1	General points .....	237
16.4.2	The tuning indicator and tuning behavior .....	238
16.4.3	Speed and robustness .....	238
16.4.4	CQ calls and broadcasts .....	239
<b>17</b>	<b>Accessories .....</b>	<b>241</b>
<b>18</b>	<b>History .....</b>	<b>243</b>
<b>19</b>	<b>Technical Data .....</b>	<b>245</b>
<b>20</b>	<b>Layout .....</b>	<b>247</b>
<b>21</b>	<b>Circuits .....</b>	<b>251</b>
<b>22</b>	<b>Connector Pin-out .....</b>	<b>257</b>
<b>23</b>	<b>Glossary .....</b>	<b>261</b>

## Table of Contents

---

## List of Figures

Figure 1.1:	The <b>SCS</b> PTC-IIpro.....	8
Figure 3.1:	The PTC rear panel.....	11
Figure 3.2:	RS232 Connections.....	12
Figure 3.3:	Connection to the transceiver.....	14
Figure 3.4:	Connections to the transceiver (5 PIN DIN).....	14
Figure 3.5:	Transceiver remote-control.....	19
Figure 3.6:	ICOM plug .....	21
Figure 3.9:	The DSP-Module-II.....	24
Figure 3.7:	The DSP-Module.....	26
Figure 3.8:	Positioning of the Packet-Radio modules.....	27
Figure 3.9:	The 1k2/2k4 AFSK-Module.....	28
Figure 3.10:	The 9k6-Module.....	30
Figure 3.11:	Packet-Radio connector (5-PIN DIN).....	31
Figure 3.12:	View of the PTC-IIpro .....	32
Figure 4.1:	The PTC-IIpro front.....	33
Figure 4.2:	The PTC-IIpro front panel.....	36
Figure 9.1:	Pin connections for the modem connector .....	146
Figure 9.2:	Flatband cable PTC-IIpro - MODEM.....	148
Figure 9.3:	Position of the Packet modem connectors .....	148
Figure 15.1:	The serial interface.....	221
Figure 15.2:	Transceiver remote-control in detail .....	222
Figure 15.3:	Masses of memory .....	223
Figure 15.4:	Mathematical artist, the processor.....	224
Figure 15.5:	All digital, the signal processor with RAM.....	224
Figure 15.6:	The PTC-IIpro switch-mode power unit.....	225
Figure 15.7:	A good connection.....	226
Figure 16.1:	Raised-Cosine-Pulse, Sampling points marked X. ...	233
Figure 16.2:	PACTOR-II spectrum 300 Bd FSK (200 Hz Shift).....	233

## List of Figures

---

## List of Tables

Table 1.1: List of programs .....	4
Table 1.2: File Types.....	5
Table 3.1: Cable Colors: 8-pole DIN-cable.....	13
Table 3.2: ICOM 8 pin connection.....	15
Table 3.3: ICOM 13 pin connection.....	15
Table 3.4: Kenwood 13 pin connection .....	15
Table 3.5: Kenwood TS-50 connection .....	16
Table 3.6: KENWOOD 6 pin Mini-DIN.....	16
Table 3.6: Yaesu connection.....	16
Table 3.7: YAESU 6 pin Mini-DIN .....	16
Table 3.8: YAESU 6 pin Mini-DIN .....	17
Table 3.9: Cable Colors: 13-pole DIN-cable.....	19
Table 3.10: KENWOOD TTL.....	20
Table 3.11: KENWOOD V24.....	20
Table 3.12: ICOM   Figure 3.6: ICOM plug .....	21
Table 3.13: YAESU FT 890/990.....	21
Table 3.14: YAESU FT 757.....	21
Table 3.15: YAESU V24.....	22
Table 3.16: Technical Details of the DSP-Module.....	25
Table 3.16: Technical Details of the DSP-Module.....	26
Table 3.16: Technical Details of the DSP-Module.....	28
Table 3.17: Technical details of the 1k2/2k4-Modul .....	29
Table 3.18: Technical Details of the 9k6-Modul .....	30
Table 3.19: Cable Colors: 5-pole DIN-cable.....	31
Table 4.1: Examples for the matrix display. ....	35
Table 5.1: Command prompts.....	38
Table 5.2: Remote commands .....	40
Table 5.3: PACTOR mailbox commands .....	42
Table 5.4: Packet-Radio mailbox commands.....	44
Table 5.5: AMTEX message types.....	48
Table 6.1: AMTOR and NAVTEX reception .....	64
Table 6.2: Conversion of German special characters. ....	89
Table 6.3: PTC status information, Bit 0-2 .....	105
Table 6.4: PTC status information, Bit 4-6 .....	106
Table 6.5: Code byte description .....	108
Table 6.6: Prompt coding .....	108
Table 8.1: JVFAX Control Bytes .....	132
Table 8.2: STTV sub modes .....	139
Table 9.1: The modem signals and their function .....	147
Table 10.1: Commands: Terminal mode / hostmode .....	169
Table 13.1: Antenna Switch Conditions .....	212
Table 16.1: Total Bit Rate .....	234
Table 16.2: The four speed settings and coding. ....	236

## List of Tables

---

## Chapter 1

### 1 Introduction

#### 1.1 **SCS-PTC, the Original**

Thank you for having decided to purchase the **SCS-PTC-IIpro**. The **SCS-PTC-IIpro** is the original, developed by those people that created PACTOR and PACTOR-II. Only from **SCS** you receive the best possible support. The concentrated knowledge of the PACTOR- engineers is available to you.

The **SCS-PTC-IIpro** is the optimized device for modern, digital short wave communication as, additional to PACTOR, all the other HF modes like AMTOR, RTTY, CW and a lot of others are supported.

**The PTC-IIpro reacts on PACTOR- and AMTOR-calls and answers automatically in the correct mode.** Because of these outstanding features the **SCS-PTC-IIpro** is the best device for all of those people that do not only want to use PACTOR, but also AMTOR. Also in mailbox systems the features of the **SCS-PTC-IIpro** can be utilized for best performance.

#### 1.2 **Requirements**

To operate PACTOR, a transceiver capable of switching between transmit and receive within 20 ms is required. Therefore any transceiver capable of AMTOR can also be used for PACTOR.

To operate the **SCS-PTC-IIpro** you need a computer or a simple terminal that provides an serial interface compatible with the RS232 (V24) standard. If you use a computer you need a appropriate terminal program to operate the serial interface with the following parameters: 8 bit, no parity and 1 stopbit. The baud rate in the range between 2400 and 115200 Baud is automatically sensed by the PTC-IIpro (Autobaud operation).

Many modern computers (especially laptops) do not have a serial COM connector. For these computers a USB to RS232 converter can be purchased from most computer stores and **SCS** representatives. With the help of this adapter you can easily operate the PTC-IIpro with the USB interface of your computer.

#### 1.3 **About this manual**

This manual contains information on the installation and operation of the **SCS** PACTOR Controller. The shortform for PACTOR Controller is PTC and is used in this manual alternatively.

The manual may be used as a reference manual for the PTC commands and as a hardware reference.

The section 3 shows how to "quick start" the PTC-IIpro. Section 16 gives basic introduction about PACTOR and PACTOR-II. Section 5 shows the command structure and operation of the PTC.

**You should additionally read sections 6.42 and 6.74. Here it is explained how the audio output signal from the PTC-IIpro is adjusted for FSK and PSK operation.**

The circuit description is contained in chapter 15.

All descriptions in this manual refer to the default settings of the PTC-IIpro. This is very important especially with respect to the freely definable control characters (ESCAPE-character in section 6.39 on page 80, BREAKIN-character in section 6.12 on page 66 CHANGEOVER-character in section 6.19 on page 69 and QRT-character in section 6.79 on page 98.

### 1.3.1 Typography

To clarify various meanings contained in this manual, various types of fonts have been used. Hereby it is intended to use the same typography for equal or similar items:

`Typewritten` is for all outputs or messages FROM the PTC.

`Sanserif` shows Instructions or Inputs (Commands) TO the PTC.

Characters inside pointed brackets <> in the following text mean that the corresponding key or key combination should be pressed. <ESC> means that the ESCAPE key should be pressed.<RETURN> characterizes the <RETURN> or ENTER key, and <Ctrl-D> that the Ctrl key should be pressed together with the 'D' key. All commands are closed with <RETURN>. Commands may be input either in upper or lower case letters, or a mixture of the two.

### 1.4 HF-email

If you intend to use the PTC-IIpro for HF-email only and not for amateur-radio purposes then 95% of this manual are not necessary for you to read. HF-email is deeply associated with the email-client (PC-programm) you use and your service provider. The email-client (e.g. Airmail) automatically does most of the configurations needed and lets you successfully transfer email at a fraction of knowledge which this book presents. So don't feel bothered by the thickness of the book but have a look into the documentation of your email-client, which will provide a well tailored description of all you need for HF-email.

If you're still looking for an email service provider then refer to our homepage where you find actual links to the sites of many service providers. When you have chosen a service provider then follow his instructions on which software you need on your PC and how it needs to be configured.

### 1.5 The SCS CD-ROM

The **SCS** CD-ROM contains software to operate the PTC-IIpro in various modes.

### 1.5.1 The programs

The PTC-IIpro offers many modes of operation of which most are related to the exchange of text or data. In addition, picture modes like FAX and SSTV are supported. To access and operate your PTC-IIpro you must run a software program on your computer (PC). Although very simple terminal software (i.e. Windows HyperTerminal) will control a PTC-IIpro, it is much more convenient to use a program which has been specially created to operate the **SCS** PTC-II series.

Many of the programs have been written on a voluntary base and are available free of charge to all users and distributed via the Internet. With the permission of the authors we have included the programs on our **SCS** CD-ROM. Third party programs are **not** developed by **SCS** and **SCS** cannot provide support for them. If you have problems or questions concerning the programs, please contact the author directly. Table 1.1 below gives you an overview on the software available for specific applications.

Program	Modes		Special Support for									Operating-System
	Text/data	Picture modes	PACTOR	HF-email	Amateur-modes	Packet-Radio	Hostmode	TRX-control	Firmw.-Update	Audio-modes	NAVTEX	
Airmail	✓	○	✓	✓	●	●	✓	✓	✓	●	●	WIN
Alpha	✓	○	✓	○	✓	✓	○	●	✓	✓	●	WIN
Easyterm EZT3271	✓	○	✓	○	✓	○	○	●	○	●	●	WIN
EasyTransfer	✓	○	✓	○	○	○	✓	○	○	○	○	WIN
EasyUpdate	○	○	○	○	○	○	○	○	✓	○	○	WIN
GSH-PC	○	✓	○	○	○	○	○	○	○	○	○	DOS
JVComm32	○	✓	○	○	○	○	○	○	○	○	○	WIN
JVFAX	○	✓	○	○	○	○	○	○	○	○	○	DOS
Kptc	✓	○	✓	○	✓	●	○	●	✓	●	●	Linux
Mscan Meteo Fax	○	✓	○	○	○	○	○	○	○	○	○	WIN
Mscan Meteo Pro	✓	✓	●	○	✓	●	○	●	○	●	✓	WIN
Mscan SSTV	○	✓	○	○	○	○	○	○	○	○	○	WIN
Mscan for DOS	○	✓	○	○	○	○	○	○	○	○	○	DOS
NCWinPTC	✓	○	✓	○	✓	✓	○	✓	✓	✓	✓	WIN
Paxon	✓	○	✓	○	○	✓	✓	○	○	○	○	WIN
PlusTerm	✓	○	✓	○	✓	✓	○	●	✓	●	●	DOS
RCKRtty	✓	○	✓	○	✓	✓	○	✓	○	●	●	WIN
Simple	✓	○	✓	○	✓	●	○	✓	○	●	●	WIN
Simple32	✓	○	✓	○	✓	●	○	✓	○	●	●	WIN
Update	○	○	○	○	○	○	○	○	✓	○	○	Linux
WinUpdate	○	○	○	○	○	○	○	○	✓	○	○	WIN
XPWin	✓	○	✓	○	✓	✓	○	✓	○	●	●	WIN

Table 1.1: List of programs

- Agenda:** ✓ Special and comfortable support provided.  
 ● Possible, but no special support provided.  
 ○ Not possible with this software.

- We are frequently asked “What is the best program for the PTC-IIpro?”. This question cannot be answered easily as it is similar to someone asking “What is the best car?” or

“What is the best operating system?”. It’s a question of personal preference and depends on the application.

If **HF email** is your application for your PTC-IIpro, it may not be necessary to study Table 1. In most cases, your HF email service provider supplies or recommends the appropriate software for their particular service.

- Transceiver control is possible with the PTC-IIpro only, not with the PTC-IIe/ex.
- Windows programs usually need Windows 98 or higher.
- PlusTerm and EasyTransfer are the only programs that have been developed by **SCS**.
- The **SCS** CD-ROM is usually updated twice the year. Always check if there is a newer version of your selected program available from the Internet.

### 1.5.2 Version numbering

Each (software) *component* has an own version number. The BIOS, the firmware, the programs for the PC and the user manual. The different version numbers are necessary to distinguish between old and new versions.

### 1.5.3 File types

Basicly the following file types (extentions) are used:

<b>.TXT</b>	Normal text
<b>.GER</b>	German text
<b>.ENG</b>	English text
<b>.PT2</b>	Firmware file for the PTC-II
<b>.PTE</b>	Firmware file for the PTC-IIe
<b>.PEX</b>	Firmware file for the PTC-IIex
<b>.PRO</b>	Firmware file for the PTC-IIpro
<b>.PTU</b>	Firmware file for the PTC-IIusb
<b>.PTN</b>	Firmware file for the PTC-IInet

Table 1.2: File Types

## 1.6 Professional solutions

**SCS** has developed a Professional version of the firmware which enables new modes for the PTC. The “Professional Firmware” meets many special requirements for mobile and maritime users and services. It also provides the high-speed **PACTOR-III** mode.

**The following overview shows the Professional Firmware features:**

- PACTOR-III highspeed data transfer protocol.
- Hayes compatible command interpreter, Hayes-mode (phone modem compatibility).

- PACTOR-IP-Bridge, direct “TCP/IP over PPP” via HF.
- PACTOR-Free-Signal-Protocol, collisions-avoiding access system to HF data services.
- More robust protocol for the PACTOR link establishment (“Robust-Connect”).
- CCIR 491-Number-SelCalls (4- and 5 characters), as well as WRU-identifier and Answerback for comfortable access to SITOR-coast-stations.

For permanent usage of the extended firmware features you need a license key from **SCS**. Without this key you can test the extended features for 20 connects. Refer to **LICENSE** command chapter 6.47 on page 84. For prices and detailed information (manual) about the Professional Firmware refer to our homepage: [www.scs-ptc.com](http://www.scs-ptc.com).

### 1.6.1 PACTOR-III

PACTOR-III is a third generation HF protocol building on latest developments in 2-dimensional orthogonal pulse shaping, advanced error control coding, and efficient source coding. Due to the advanced signal processing methods applied, PACTOR-III provides outstanding performance under poor and moderate signal conditions. As PACTOR-III also achieves very high throughput rates under good signal conditions, it is well-suited to HF channels with good SNR and low signal distortion as well. During the development of PACTOR-III, high importance was attached to compatibility with ordinary SSB transceivers (using standard 2.2-2.4 kHz wide IF-filters). Therefore, PACTOR-III can achieve its maximum speed with using unmodified, common SSB transceivers. The occupied bandwidth is around 2200 Hz.

Thus PACTOR-III is the ideal means of fast and reliable data communication over (the sometimes difficult medium) HF-radio. The new protocol is fully backwards compatible to existing PACTOR-I/II networks.

#### **The properties of the PACTOR-III protocol summarized:**

- Under virtually all signal conditions, PACTOR-III is faster than PACTOR-II. Under average signal conditions a speed gain by a factor 3x to 4x is achieved, under very favourable conditions the speed improvement can exceed 5x.
- Maximum data throughput (without compression) greater than 2700 Bit/sec, around 5200 Bit/sec if PMC (online text compression) is applied.
- PACTOR III is at least as robust as PACTOR-II under extremely poor signal conditions.
- Maximum bandwidth only about 2200 Hz.
- Low crestfactor (high mean output power).
- High spectral efficiency – PACTOR-III makes very good use of the bandwidth.
- Fully backwards compatible to existing PACTOR-I/II networks.

### 1.6.2 PACTOR-IP-Bridge

The PACTOR-IP-Bridge (PIB) is a new Network –Integration Protocol developed by **SCS**. The dominant protocols of the Internet like TCP/IP, as well as the Point-to-Point Protocol (PPP), which have become standard for establishment of links between Internet applications, are combined with the PACTOR modes. The result of this intelligent protocol combination is a data transparent and relatively fast Internet access via HF-radio using standardized user interfaces. The PTC appears to an attached PC as if it were a Hayes compatible "telephone modem". The PTC locally takes over both the complete PPP and TCP/IP handling. Except for a minimum fraction of protocol overhead, the physical PACTOR link only carries useful data. The huge amount of overhead of the TCP/IP and PPP protocols (which are designed for broad banded wired links) is reduced to the absolute minimum required. By locally carrying out the PPP protocol between the PC and the PTC a further decisive advantage arises: Because of the very short timeouts, PPP used to be nearly impossible over slow communication channels with relatively large delays. Timeout problems are now solved by the PACTOR-IP-Bridge.

Summarizing the qualities of the PIB:

- TCP/IP-transparent and relatively fast Internet access via HF-radio.
- Internet-services accessible via PACTOR, e.g. E-Mail (SMTP/POP3), FTP, HTTP, ...
- Up to 4 Internet channels ("sockets") over one physical PACTOR link.
- Extreme compression of the TCP/IP and PPP"overhead".
- Full PPP compatibility: Use of common client/server-software, like Netscape, Outlook, Eudora and others is possible.
- Easy embedding and configuration under all common operating systems.
- No "timeout"-problems on PPP and TCP/IP.

As host system for the PACTOR-IP-Bridge **SCS** has developed the PTC-IIinet.

A detailed manual for the *Professional Firmware* can be found on our homepage <http://www.scs-ptc.com>.

### 1.6.3 EasyTransfer

EasyTransfer is a program developed for binary transparent file-transfers between two computers connected via PACTOR. The graphical user interface is similar to some well known FTP clients, which are used for file –transfers via the Internet. When viewing the software user interface, the left side shows the contents of the local hard disk, on the right are the contents of the enabled REMOTE directory of the PACTOR connected server. Files can easily be moved between the two sides using standard drag-and-drop actions. In addition to FTP, EasyTransfer has a "chat" mode to exchange hand typed messages. With that, EasyTransfer is the ideal tool to exchange computer data via HF and over unlimited distances.

## 1 Introduction

---



Figure 1.1: The **SCS** PTC-IIpro

## Chapter 2

### 2 Customer Support

If you have questions, problems, proposals, or comments relating to the PTC-IIpro or PACTOR, please contact the following address.

#### **SCS**

Special Communications Systems GmbH & Co. KG

Roentgenstrasse 36

63454 Hanau

Germany

Fax.: +49 6181 23368

Order Fax.: +49 6181 990238

E-Mail: [info@scs-ptc.com](mailto:info@scs-ptc.com)

#### **Homepage**

Visit our Internet sites:

<http://www.scs-ptc.com>

Here you will find:

- Information to PACTOR and our modems
- The actual firmware versions
- Additional interesting software for the PTC-IIpro
- Links to related sites

On our homepage you can also subscribe to our mailing list to get actual information about PACTOR and the PTC-IIpro automatically by e-mail.

## 2.1 If you have a problem

If a problem occurs and it's necessary to send your **SCS** product to maintenance, please take care of the following:

- Package the device with care. Use suitable and enough packaging material.
- Attach a cover note to the shipment. Do this **always**, also if you have e-mailed or talked to us previously.
- Describe the problem as good as you can.
- Write clearly.
- Don't forget your return address!

If the PTC-IIpro shows a *strange* behavior perhaps using the command **REStart** can help. Sometimes and because of playing around important parameters may be misadjusted. The **REStart** command totally restarts the PTC-IIpro. The default settings of all parameters will be restored.

## Chapter 3

### 3 Installation

The installation of the PTC-IIpro is simple, as all settings are done via software. You need only correctly configure the cable between the PTC-IIpro and transceiver, if this is not already available.

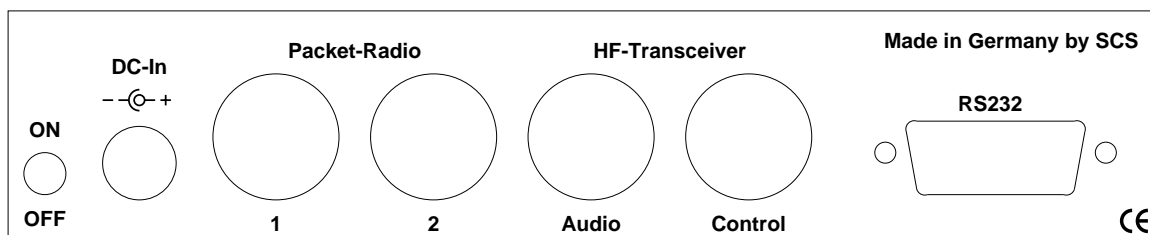

Figure 3.1: The PTC rear panel.

#### 3.1 Power supply

The PTC-IIpro has two inputs for its power connections which can be used alternatively. Either connect via the DC-in supply socket at the rear of the unit, or via the connector for the short-wave transceiver (Audio). Both connections are decoupled with diodes and protected against reverse polarity. An input voltage between 10...20 VDC is allowed, the current consumption depends due to use of a switch mode regulator internally on the input voltage and how the PTC-IIpro is equipped (e.g. Modems, RAM etc) and also the present processor speed. It is usually around 200 mA at 13.8 V. Basically the higher the input voltage the lower the current consumption. The power supply inputs on the PTC-IIpro are especially filtered so that harmonics of the switch mode regulator cannot pass outside the unit. The inputs are also protected by a self-resetting fuse.

#### 3.2 The serial interface (RS232/V24)

The **SCS**-PACTOR controller communicates with the computer or terminal via a serial interface using the RS232/V24 standard.

For communication between PTC and computer, the data format is **8 bits, 1 stopbit, no parity and half duplex**. The baudrate can either be automatically sensed by the PTC, or set via a command to a given value (see **SERBaud** command, chapter 6.87, page 101).

If the auto baudrate sensing is active, then, after switching on, the PTC waits for keyboard input. **AUTOBAUD** and **press CR** are displayed alternately on the digital display. It will then wait, until either the operator, or the terminal program, sends an appropriate character. The PTC reacts to <CR>, <ESC>, and the freely programmable ESCchr (refer to chapter 6.39, page 80). Due to the internal operation of the processor, the auto baudrate sensing can use only characters with an odd ASCII value: <CR> (ASCII 13), <ESC> (ASCII 27) or as an example for the freely programmable ESCchr <Ctrl-A> (ASCII 1), <Ctrl-C> (ASCII 3).

## 3 Installation

The connection for the serial interface is the 9-pole SUB-D socket on the rear of the PTC. The connection type is that of a modem (DCE) with a 9-pole SUB-D socket. The PTC can thus be connected to the computer with a standard 9-pole cable (1 to 1 connections). All handshaking lines are connected and can be controlled by the PTC. In the present PACTOR software, however, handshaking is not used.

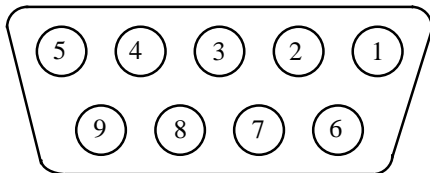

Figure 3.2: RS232 Connections

- Pin 1: CD - Output (Scan Stop).
- Pin 2: TxD - Transmit data output (to computer).
- Pin 3: RxD - Receive data input (from computer).
- Pin 4: DTR - Input (RxD secondary serial port).
- Pin 5: Ground (GND).
- Pin 6: DSR - Output.
- Pin 7: CTS - Input.
- Pin 8: RTS - Output.
- Pin 9: RI - Output (TxD secondary serial port).

For more information for the Scan-Stop-Signal (refer to chapter 13.23, page 210).

The handshake signals (pin 4 and 9) are used as secondary RS232 channel e.g. to connect a GPS receiver to the PTC-IIpro.

### 3.3 Connections to the transceiver

PACTOR-II uses Differential Phase Shift Keying (DPSK), which leads to a very narrow bandwidth signal. In order to maintain this advantage of PACTOR-II on the bands, correct setting up of the transceiver is required. Overdriving of the transceiver will lead to a greatly increased bandwidth. The optimal adjustment from the PTC-IIpro to the radio equipment is described in chapter 3.3.4 on page 17.

**The complex PACTOR-II modulation scheme is totally different, and has nothing whatsoever to do with simple FSK. It is therefore IMPOSSIBLE to use the FSK modulators found in some transceivers to generate the signal. The PACTOR-II signal must always go via the indirect route, by using SSB to generate the HF signal. This is of no disadvantage providing the transceiver is not overdriven.**

Some hints to adjust the settings of your transmitter:

- If possible use a 500 Hz IF-filter. Never use a IF-filter with a smaller bandwidth than 500 Hz! IF filter (SSB-filter) with wider bandwidths won't cause problems at all. Although the filtering by the DSP of the PTC-IIpro is always optimized, it is desirable to prevent noise from the input of the PTC-IIpro as far as possible.
- Under no circumstances use audio processors. The peech-compressor of the transceiver will damage the PACTOR-II signal in the same way as external DSP audio filters being so popular at the moment. These external DSP audio filters create unpredictable signal propagation delays which are absolutely undesirable. The PTC-IIpro filters the signal optimal with the integrated DSP and needs no "external help".
- Noise blanker and notch filter should be switched off.

The PTC is connected to the transceiver via an 8 PIN DIN socket.

### 3 Installation

---

**PIN 1: Audio output from the PTC to the transmitter.** The PTC-IIpro supplies a pure audio signal to the microphone input of the transceiver. The output amplitude can be adjusted with the **FSKA** and **PSKA** commands from 30 to 3000 mV (peak to peak) open circuit. The output impedance of the PTC-IIpro is 1 k $\Omega$ .

**PIN 2: Ground (GND).** Collective grounding point for all signals.

**PIN 3: PTT output.** While transmission this output from the PTC-IIpro is grounded, so that virtually all modern transceivers are suitable. A VMOS-field-effect transistor is used as the switch, which gives optimum results. The switched current should not exceed 1 A.

**PIN 4: Audio from the receiver to the PTC-IIpro.** The PTC-IIpro gets its information directly from the loudspeaker output of the receiver. The volume should not be turned up too far. A *fairly low* volume is quite sufficient. It is better to take the AF signal from a low level output which is independent of the volume control. These outputs are often labeled AUX or ACC. The input impedance of the PTC is 47 k $\Omega$ . The PTC-IIpro operates with an input signal down to approx. 5 mV<sub>RMS</sub> and should not exceed 1 V<sub>RMS</sub>.

**PIN 5: Optional power supply input.** The PTC can be supplied with power via this input. This is especially useful if the transceiver gives a power supply output via the AUX socket. The PTC-IIpro requires approximately 9 to 20 Volts DC at a maximum of 1A.

**PIN 7: FSK output from the PTC to the transmitter.** When using the modes PACTOR-I, AMTOR and RTTY, an additional FSK keying output is available. This may be connected to the FSK input of the transmitter (often labeled as RTTY). The PTC-IIpro output uses TTL levels. High is equivalent to Mark, low is Space.

The A0/A1 connections might be used for automatic and frequency dependent antenna switching. For more information refer to chapter [13.25.2](#) on page [211](#).

**PIN 6: A1.** General purpose switch output (can e.g. be used to control an antenna switch). When active, the output is switched to ground (for technicians: open Drain).

**PIN 8: A0.** General purpose switch output (can e.g. be used to control an antenna switch). When active, the output is switched to ground (for technicians: open Drain).

Use the attached 8-pole DIN cable to connect the PTC-IIpro to the transceiver:

PIN	Color	PIN	Color
1	Violet	5	Blue
2	White	6	Red
3	Yellow	7	Black
4	Green	8	Brown

Table 3.1: Cable Colors: 8-pole DIN-cable

### 3 Installation

The socket is wired as follows (Viewed from the rear of the PTC-IIpro).

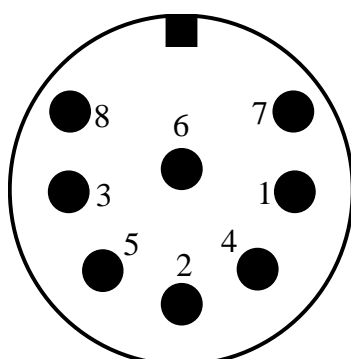

- Pin 1: Audio output from the PTC to the transmitter.
- Pin 2: Ground.
- Pin 3: PTT output. (to transmitter PTT line)
- Pin 4: Audio input from the receiver to the PTC.  
(loudspeaker or appropriate AUC/ACC socket)
- Pin 5: Optional power supply input.
- Pin 6: A1.
- Pin 7: FSK output from the PTC to the transmitter.
- Pin 8: A0.

Figure 3.3: Connection to the transceiver.

**NOTE:** Unfortunately, there are 8-pole plugs with different pin numbering for the PINs 7 and 8. The PTC-IIpro needs an 8-pole plug with U-shaped contact footprint. Plugs with circular contact footprint don't fit or can only be connected to the PTC-IIpro with damaging force! One should not blindly rely on the printed numbers on the plug. The connections as shown here in the handbook should be used as a reference.

The 8-pole DIN socket is mechanically designed that a 5-pole DIN plug (180°) may be plugged into it too. An existing cable for the Z80-PTC can be used without changes, the pin-out is the same of the Z80-PTC set for AFSK.

It is possible to use a 5-pole DIN plug if an 8 pin is not available, or the extra functions are not required. If a 5 pin DIN plug is used, then the connections are as shown:

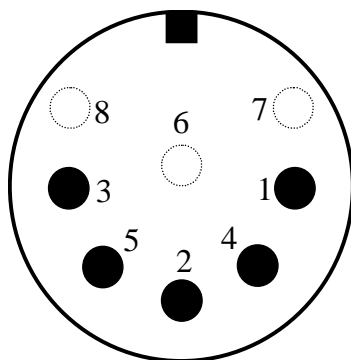

- Pin 1: Audio output from the PTC to the transmitter.
- Pin 2: Ground.
- Pin 3: PTT output. (to transmitter PTT line)
- Pin 4: Audio input from the receiver to the PTC.  
(loudspeaker or appropriate AUX socket)
- Pin 5: Optional power supply input.

Figure 3.4: Connections to the transceiver (5 PIN DIN).

### 3.3.1 Connection to ICOM transceivers:

Most ICOM transceivers that use 8 pin DIN plug (ACC) can be connected this way:

Signal	PTC	Color	ICOM 8 pin
GND	PIN 2	white	PIN 2
PTT	PIN 3	yellow	PIN 3
AF-OUT	PIN 1	violet	PIN 4
AF-IN	PIN 4	green	PIN 5
POWER	PIN 5	blue	PIN 7
<b>This cable is available completely assembled. Refer to Appendix A on page 241.</b>			

Table 3.2: ICOM 8 pin connection

The *smaller* ICOM transceivers (e.g. IC-706) often use a 13 pin DIN plug for ACC:

Signal	PTC	Color	ICOM 13 pin
GND	PIN 2	white	PIN 2
PTT	PIN 3	yellow	PIN 3
AF-OUT	PIN 1	violet	PIN 11
AF-IN	PIN 4	green	PIN 12
POWER	PIN 5	blue	PIN 8
<b>This cable is available completely assembled. Refer to Appendix A on page 241.</b>			

Table 3.3: ICOM 13 pin connection

### 3.3.2 Connection to Kenwood transceivers:

Most Kenwood transceivers that use 13 pin DIN plug (ACC2) can be connected this way:

Signal	PTC	Color	Kenwood
GND	PIN 2	white	PIN 4, 8, 12
PTT	PIN 3	yellow	PIN 9
AF-OUT	PIN 1	violet	PIN 11
AF-IN	PIN 4	green	PIN 3
<b>This cable is available completely assembled. Refer to Appendix A on page 241.</b>			

Table 3.4: Kenwood 13 pin connection

## 3 Installation

---

The TS-50 can only be connected via the microphone jack:

Signal	PTC	Color	Kenwood
GND	PIN 2	white	PIN 7, 8
PTT	PIN 3	yellow	PIN 2
AF-OUT	PIN 1	violet	PIN 1
AF-IN	PIN 4	green	PIN 6

Table 3.5: Kenwood TS-50 connection

The TS-480 has a 6 pin Mini-DIN connector:

Signal	PTC	Color	YAESU
GND	PIN 2	white	PIN 2
PTT	PIN 3	yellow	PIN 3
AF-OUT	PIN 1	violet	PIN 1
AF-IN	PIN 4	green	PIN 5

**This cable is available completely assembled.  
Refer to Appendix A on page 241.**

Table 3.6: KENWOOD 6 pin Mini-DIN

### 3.3.3 Connection to Yaesu transceivers:

Some YAESU transceivers use a 5 pin DIN plug (Packet) and can be connected this way:

Signal	PTC	Color	YEASU
GND	PIN 2	white	PIN 2
PTT	PIN 3	yellow	PIN 3
AF-OUT	PIN 1	violet	PIN 1
AF-IN	PIN 4	green	PIN 4

Table 3.7: Yaesu connection

Smaller YAESU's use a 6 pin Mini-DIN connector, whereby with multiband transceivers two different connection schemes must be distinguished:

- For HF and 1k2 Packet-Radio:

Signal	PTC	Color	YAESU
GND	PIN 2	white	PIN 2
PTT	PIN 3	yellow	PIN 3
AF-OUT	PIN 1	violet	PIN 1
AF-IN	PIN 4	green	PIN 5

**This cable is available completely assembled.  
Refer to Appendix A on page 241.**

Table 3.8: YAESU 6 pin Mini-DIN

## 3 Installation

- For 9k6 Packet-Radio:

Signal	PTC	Color	YAESU
GND	PIN 2	white	PIN 2
PTT	PIN 3	yellow	PIN 3
AF-OUT	PIN 1	violet	PIN 1
AF-IN	PIN 4	green	PIN 4

**This cable is available completely assembled.  
Refer to Appendix A on page 241.**

Table 3.9: YAESU 6 pin Mini-DIN

### 3.3.4 Amplitude Adjustment

The PTC-IIpro output amplitude has to be adjusted very carefully to the connected transceiver. If you don't pay attention on this item a signal much too wide will be the result!

The output amplitude are adjusted separately depending on the modes FSK (PACTOR-I, AMTOR, RTTY, etc). and the modes PSK (PACTOR-II). A common adjustment with one command was in practice not the best way.

The audio input sensitivity of most transceivers is adapted to the output voltage of a common dynamic microphone. 100 % modulation is reached at low MIC-Gain settings with 200 mV (Peak to peak) input voltage. It is not recommended to use very high **PSKAmp1** values and compensate this by lowering the MIC-Gain setting, because this may already overdrive the first amplifier stages which are very sensitive and located in the signal path before the MIC-Gain controlling device. We recommend for the first approach to use the default PSKA value of 140 and then regulate the output power for PSK with the mic-gain setting (if available). To do this connect the TRX to a dummyload resistor capable to dissipate the power or to an antenna with good SWR (Take care that the frequency being used is not already occupied). Entering `U 3 <Return>` starts the Unproto mode 3 (=100 Bd DBPSK). Now you can use the MIC-Gain knob to increase the transmitting power until the ALC voltage reaches the allowed limit.

Don't overdrive the TRX because in this case the signal will be spreaded by intermodulation!

With proper settings the peak envelope power will nearly be equal to the maximum output power of the TRX. In this case the average power will approximately be the half of the maximum power, so also continuous operation will not cause problems at all. Don't be confused as many modern TRX only display the peak envelope power. If it is necessary to set the MIC-Gain value to more than half of ist maximum, it is recommended to increase the **PSKAmp1** value. This for example can be done entering `<ESC> FSKA 200 <RETURN>` If no MIC-Gain potentiometer is available the proper PSK amplitude setting has to be evaluated with only using the **PSKAmp1** command.

## 3 Installation

After the PSK amplitude is carefully adjusted, the MIC-Gain setting at the transceiver should not be touched any more, otherwise it could be difficult to achieve the desired output level for non-PSK modes.

To adjust the output level for non-PSK modes (FSK, CW, PACTOR-I, AMTOR, RTTY) only the **FSKAmp1** command should be used now. Entering **U 1** <RETURN> starts the Unproto mode 1 (=100Bd FSK). Now you have the chance to adjust the output value using the **FSKAmp1** command e.g. <ESC> **FSKA 100** <RETURN>. Same as before, during this procedure take care for not to exceed the ALC limit.

To prevent damage from the transceiver at continuous operation we recommend to limit the FSK output level to half of the maximum possible, that means 50 W if the transceiver is made for 100 W at max.

### 3.3.4.1 PACTOR-III

For optimum PACTOR-III data throughput, the transmit signal must be clean and undistorted. Make sure that ground loops and RF feedback effects are avoided in your installation. A 1:4 voltage divider placed directly at the transmit audio input of the transmitter may help to improve the effective transmit SNR. Then you have to set FSKA and PSKA to appropriate higher signal levels. PSKA levels lower than 80 are generally not recommended. If possible, minimize the wiring between the PTC and other devices: If the transceiver provides a power supply output (e.g. 13.8 V), do not use an extra power supply for the PTC but connect the PTC to the DC output of the transceiver. Use additional RF chokes wherever applicable.

Do not overdrive the transmitter (under no circumstances): The ALC level must not exceed the proper range!

Some “noise blankers” as well as other “noise reduction tools” tend to distort the PACTOR-III receive signal. In case of receiving problems try out if switching off the “noise blanker” etc. improves the throughput.

Make sure that the PACTOR-III receive signal is centered properly within the IF filter passband (see “tone monitor”). Adjusting the “passband tuning / IF shift” improves the throughput in some cases.

## 3.4 Transceiver Remote Control

The **SCS** PTC-IIpro is equipped with a connector for controlling all the usual modern amateur radio transceivers. Virtually all newer transceivers from KENWOOD, ICOM, YAESU, SGC and R&S allow remote controlling of various functions, via a serial interface. Depending on type and manufacturer, almost all the transceiver parameters can be called up and changed. For example frequency, filter, operating mode, and much more, can be controlled. With radio equipment that is digitally controlled, the list of functions is almost unlimited.

### 3 Installation

The PTC-IIpro uses this features mainly to set and readout the frequency of the transceiver. You find more about the transceiver remote control in chapter 13 on page 199.

The 13 PIN DIN Remote-control socket is connected as follows. (**Viewed from the back of the PTC-IIpro**):

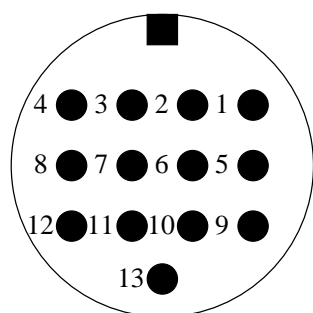

Figure 3.5: Transceiver remote-control

- Pin 1: RxD TTL.
- Pin 2: RTS V24.
- Pin 3: TXD V24.
- Pin 4: CTS V24.
- Pin 5: CTS TTL.
- Pin 6: ICOM.
- Pin 7: Not connected.
- Pin 8: RxD V24.
- Pin 9: TxD TTL.
- Pin 10: RTS TTL.
- Pin 11: AF out.
- Pin 12: AF GND.
- Pin 13: GND.

- TxD TTL** Transmit data from the PTC to the transceiver. TTL-level!
- RxD TTL** Receive data from the transceiver to the PTC. TTL-level!
- CTS TTL** Handshake signal from the transceiver to the PTC. TTL-level!
- RTS TTL** Handshake signal from the PTC to the transceiver. TTL-level!
- TxD V24** Transmit data from the PTC to the transceiver. V24-level!
- RxD V24** Receive data from the transceiver to the PTC. V24-level!
- CTS V24** Handshake signal from the transceiver to the PTC. V24-level!
- RTS V24** Handshake signal from the PTC to the transceiver. V24-level!
- ICOM** Special bi-directional data signal for controlling ICOM equipment.
- GND** Ground.
- NF out** Audio output signal that can directly be connected to a speaker. This
- NF GND** RETURN for the speaker signal **NF out**

To connect the PTC-IIpro to your transceiver use the attached 13-pole DIN-cable.

PIN	Color	PIN	Color
1	violet	8	red
2	white	9	pink
3	yellow	10	light blue
4	green	11	black/white
5	blue	12	grey
6	black	13	orange
7	brown		

Table 3.10: Cable Colors: 13-pole DIN-cable

## 3 Installation

All unused wires of the TRX control cable **must not** be twisted or soldered together. All unused wires have to be **insulated seperately** avoiding to touch each others.

### 3.4.1 Connections PTC - KENWOOD

Many KENWOOD radios use a 6 pin DIN socket for remote control. With some equipment types however, the serial interface has to be modified. Please read the equipment handbook or consult your dealer.

Signal	PTC	Color	KENWOOD
TxD	PIN 9	pink	PIN 3
RxD	PIN 1	violet	PIN 2
CTS	PIN 5	blue	PIN 5
RTS	PIN 10	light blue	PIN 4
GND	PIN 13	orange	PIN 1

Table 3.11: KENWOOD TTL

Newer Kenwood transceiver (since TS-570) have a 9-pole-sub-D connector and operate with V24 levels for transceiver control. It's intended for direct connection to a COM port of a PC. Also these transceivers can easily be controlled by the PTC-IIpro. Just solder a 9-pole connector to the attached cable as shown in the following table below.

Signal	PTC	Color	KENWOOD
TxD	PIN 3	yellow	PIN 3
RxD	PIN 8	red	PIN 2
CTS	PIN 4	green	PIN 8
RTS	PIN 2	white	PIN 7
GND	PIN 13	orange	PIN 5
<b>This cable is available completely assembled. Refer to Appendix A on page <a href="#">229</a>.</b>			

Table 3.12: KENWOOD V24

Also have a look to the accessory-list for a completely assembled cable.

### 3.4.2 Connections PTC - ICOM

Nearly all ICOM equipment has a 3.5 mm jack socket for remote control. Bi-directional communication is carried out over a single cable, in order that data can be both sent and received. Various equipment carries different addresses, so it is possible for more than one piece of equipment to be connected to the remote control cable. Further information can be found in the appropriate literature from ICOM.

Signal	PTC	Color	ICOM
ICOM	PIN 6	black	inner
GND	PIN 13	orange	outer
<b>This cable is available completely assembled. Refer to Appendix A on page 229.</b>			

Table 3.13: ICOM

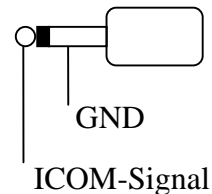

Figure 3.6: ICOM plug

### 3.4.3 Connections PTC - YAESU

Many new YAESU radios, like the FT890 or FT990, contain a 6 PIN Mini-DIN socket for remote control. Please read the equipment handbook or consult your dealer.

Signal	PTC	Color	YAESU
TxD	PIN 9	pink	PIN 3
RxD	PIN 1	violet	PIN 2
GND	PIN 13	orange	PIN 1

Table 3.14: YAESU FT 890/990

The FT980 is equipped with a normal 6-pole DIN socket for remote control use. The pin connections are according to [Table 3.14](#).

Due to an error in the PTC-IIpro main processor, it is unfortunately not possible to directly read out the frequency of YAESU transceivers. The following circuit however allows this error to be corrected and the readout to be done.

Older transceivers like the FT757 supports serial input only. In this case the PTC-IIpro adjusts the frequency but could not read-out it.

Signal	PTC	Color	YAESU
TxD	PIN 9	pink	PIN 3
GND	PIN 13	orange	PIN 1

Table 3.15: YAESU FT 757

Newer Yaesu transceiver (e.g. FT-920, FT847, FT-1000MP) have a 9-pole-sub-D connector and operate with V24 levels for transceiver control. It's intended for direct connection to a COM port of a PC. Also these transceivers can easily be controlled by the PTC-IIpro. Just solder a 9-pole connector to the attached cable as shown in the following table below.

### 3 Installation

---

Signal	PTC	Color	YAESU
TxD	PIN 3	yellow	PIN 3
RxD	PIN 8	red	PIN 2
GND	PIN 13	orange	PIN 5
<b>This cable is available completely assembled. Refer to Appendix A on page <a href="#">229</a>.</b>			

Table 3.16: YAESU V24

Portable transceivers like the FT-100, FT-817 or FT-897 use a 8 pin Mini-DIN connection:

Signal	PTC	Color	YAESU
TxD	PIN 1	violet	PIN 4
RxD	PIN 9	pink	PIN 5
GND	PIN 13	orange	PIN 3
<b>This cable is available completely assembled. Refer to Appendix A on page <a href="#">229</a>.</b>			

Don't forget to set the exact transceiver-type using the **YType** command! Refer to chapter [13.22](#) on page [210](#).

### 3.5 The Packet-Radio Modules

The optional DSP Packet-Radio-Module-II expands the PTC-IIpro to a universal multiport controller. It provides the following modes:

- 600 Baud Robust HF-Packet
- 300 baud AFSK (modem tones are fixed to 2300/2100 Hz, *High-Tones*)
- 1200 baud AFSK
- 9600 baud FSK (direct-FSK, compatible to G3RUH standard)
- 19200 baud FSK (direct-FSK, compatible to G3RUH standard)

The well known AFSK- and FSK-modules and the DSP-module are out of production and are mentioned here for completeness only.

- **AFSK module:** for 1200 and 2400 baud AFSK with a standard modem chip TCM3105 and a fully digital carrier detection.
- **FSK module:** for the G3RUH compatible FSK method (9600 Baud etc).
- **DSP module:** for 300, 1200 baud AFSK and 9600, 19200 baud FSK (G3RUH standard).

The modules contain all necessary electronics for signal processing. The actual packet protocol processing is done within the PTC-IIpro.

Don't forget to adjust the output amplitude of the Packet modules to your transceiver!

#### 3.5.1 Installation

The modules must be installed very carefully. Please check that all pins on the PTC-IIpro are correctly plugged to the corresponding socket of the modem. Checking three times is better than switching on the PTC-IIpro with an incorrectly plugged in modem !!

Figure 3.9 shows the position of both packet-radio modules. It does not matter which socket is used for which modem module. The PTC-IIpro automatically checks after power-on if a module is installed and which it is. The module(s) found are announced in the power-on message, or may be viewed using the Version command.

#### 3.5.2 The DSP-Module-II

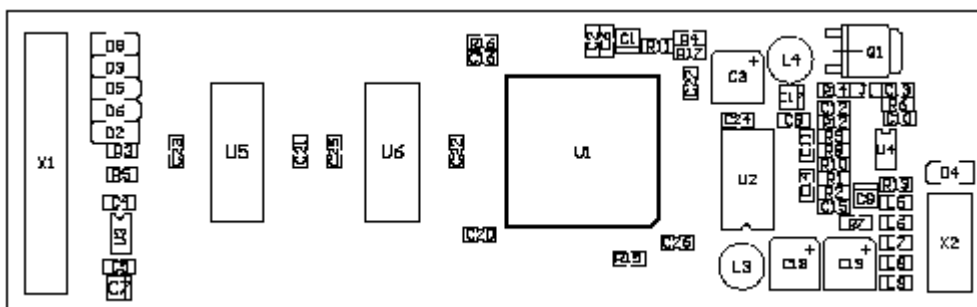

### 3 Installation

---

Figure 3.7: The DSP-Module-II.

To use the DSP-Module-II you need firmware version 3.6 or higher!

The **SCS** DSP-Module-II is an universal module for 300, 1200, baud AFSK, 9600 and 19200 baud FSK (G3RUH compatible), as well as for 600 baud robust HF Packet. The use of a signal-processor ensures optimized filtering and demodulation for the supported modes. With this the best possible performance in Packet-Radio can be achieved.

The PTC-IIpro automatically recognizes the DSP-PR-module directly after power-on and loads the DSP software into the module. Recognition and successful initialization of the module is signalled by a short blink of the connected-LED of the corresponding port.

As the software of the DSP-PR-module is a part of the PTC-IIpro firmware it can be improved and expanded via firmware updates. The enormous flexibility of the PTC-IIpro concept also includes the packet radio side.

The choice or setting of the correct modulation for the actual baudrate is automatically made by the PTC-IIpro. The DSP PR modem is capable of full duplex and mixed baudrate in all modes.

The DSP concept for PR also allows the software setting and adjustment of all modem parameters. The output-level is set with the command **TXLevel** (see chapter 9.6.38 on page 165) in the range of 20mVpp to 3Vpp. The adjustment of a potentiometer is not necessary.

The PTT-transistor is a powerful VMOS-FET which can reliably switch 16V at 1A to ground.

The input-sensitivity of the module can be chosen by the jumper J1. The initial condition of the jumper is closed. It can be found on the component location plan as a 0  $\Omega$  resistor on the left side of the PTT transistor Q1.

For 9k6 operation your transceiver requires a special connection. The modulation voltage is fed direct to the modulator, and the received signal is taken directly from the demodulator. Newer equipment sometimes offers a so called data connector. These "hybrid" radios are suitable for 9k6 operation without modifications. As the data connectors of all manufacturers have the same pin connections, **SCS** offers a special cable for use with these transceivers. Transceivers without a data connector require modification for direct access to the modulator and demodulator. Information concerning modifications can be found in practically all Packet-Radio mailboxes.

Here are the technical details:

Modulation	AFSK (Audio-Frequency-Shift-Keying) or FSK (Frequency-Shift-Keying)
AF output voltage	20 mVpp to 3Vpp adjustable. The output is muted while on receive.
Output impedance	approx. 1 k $\Omega$
AF input	100 mVpp to 1.6 Vpp (J1 open) 100 mVpp to 8Vpp (J1 closed)
Input impedance	approx. 47 k $\Omega$
PTT	max. 16 V, 1 A to GND

Table 3.17: Technical Details of the DSP-Module

### 3.5.3 The DSP-Module

**This module is out of production and is replaced by the DSP-Module-II.**

The **SCS** DSP-module is an universal module for 300, 1200, baud AFSK, 9600 and 19200 baud FSK (G3RUH compatible). The use of a signal-processor ensures optimized filtering and demodulation for the supported modes. With this the best possible performance in Packet-Radio can be achieved.

The PTC-IIpro automatically recognizes the DSP-PR-module directly after power-on and loads the DSP software into the module. Recognition and successful initialization of the module is signalled by a short blink of the connected-LED of the corresponding port.

As the software of the DSP-PR-module is a part of the PTC-IIpro firmware it can be improved and expanded via firmware updates. The enormous flexibility of the PTC-IIpro concept also includes the packet radio side.

The choice or setting of the correct modulation for the actual baudrate is automatically made by the PTC-IIpro. The DSP PR modem is capable of full duplex and mixed baudrate in all modes.

The DSP concept for PR also allows the software setting and adjustment of all modem parameters. The output-level is set with the command **TXLevel1** (see chapter 9.6.38 on page 165) in the range of 20mVpp to 3Vpp. The adjustment of a potentiometer is not necessary.

The PTT-transistor is a powerful VMOS-FET which can reliably switch 16V at 1A to ground.

The input-sensitivity of the module can be chosen by the jumper J1. The initial condition of the jumper is closed. It can be found on the component location plan as a 0  $\Omega$  resistor on the left side of the PTT transistor Q1.

For 9k6 operation your transceiver requires a special connection. The modulation voltage is fed direct to the modulator, and the received signal is taken directly from the

### 3 Installation

---

demodulator. Newer equipment sometimes offers a so called data connector. These “*hybrid*” radios are suitable for 9k6 operation without modifications. As the data connectors of all manufacturers have the same pin connections, **SCS** offers a special cable for use with these transceivers. Transceivers without a data connector require modification for direct access to the modulator and demodulator. Information concerning modifications can be found in practically all Packet-Radio mailboxes.

Here are the technical details:

Modulation	AFSK (Audio-Frequency-Shift-Keying) or FSK (Frequency-Shift-Keying)
AF output voltage	20 mVpp to 3Vpp adjustable. The output is muted while on receive.
Output impedance	approx. 1 k $\Omega$
AF input	100 mVpp to 1.6 Vpp (J1 open) 100 mVpp to 8Vpp (J1 closed)
Input impedance	approx. 47 k $\Omega$
PTT	max. 16 V, 1 A to GND

Table 3.18: Technical Details of the DSP-Module

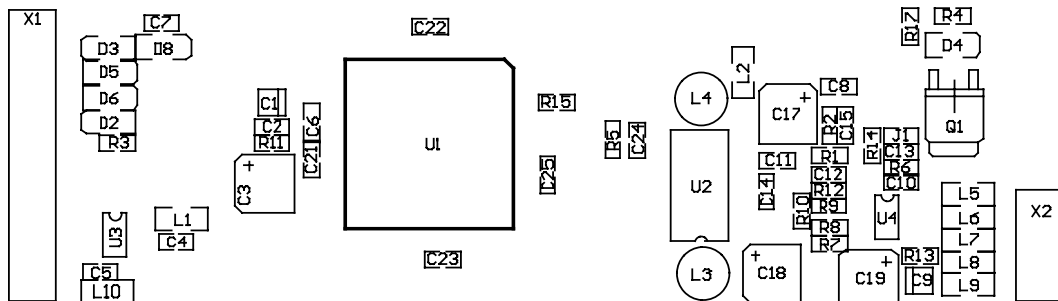

Figure 3.8: The DSP-Module.

### 3 Installation

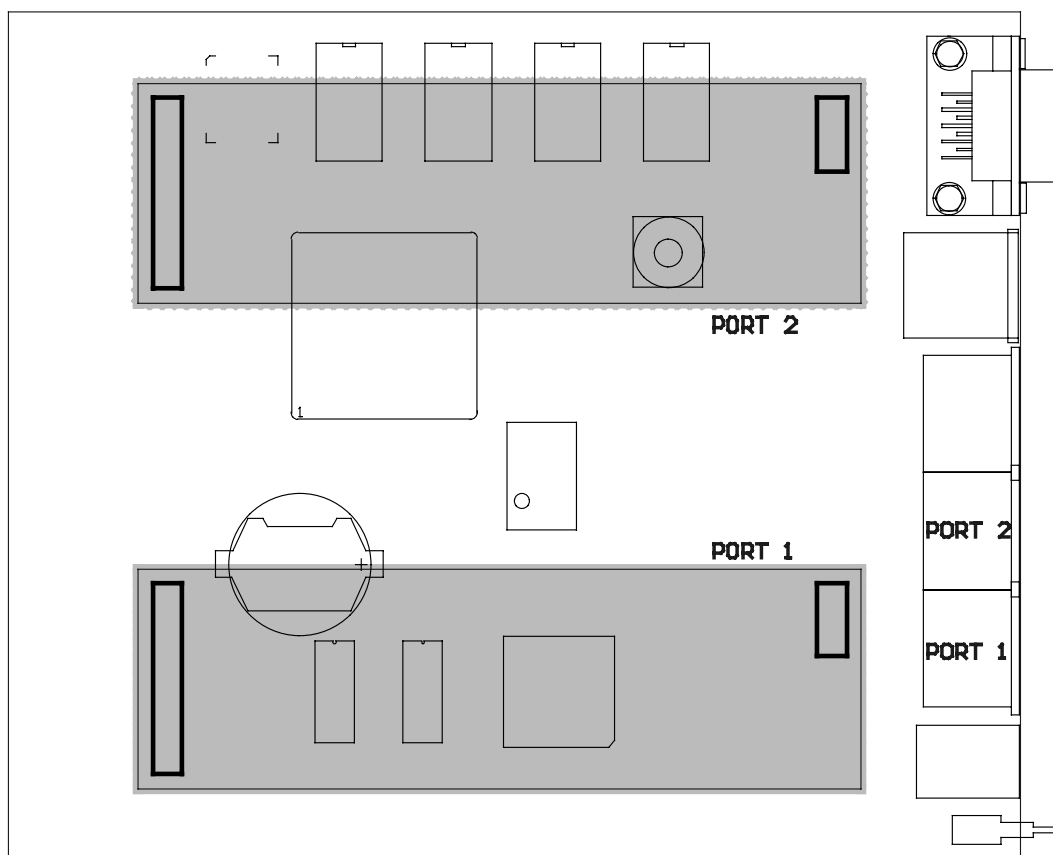

Figure 3.9: Positioning of the Packet-Radio modules.

The PTC-IIpro automatically recognizes the DSP-PR-module directly after power-on and loads the DSP software into the module. Recognition and successful initialization of the module is signalled by a short blink of the connected-LED of the corresponding port.

As the software of the DSP-PR-module is a part of the PTC-IIpro firmware it can be improved and expanded via firmware updates. The enormous flexibility of the PTC-IIpro concept also includes the packet radio side.

The choice or setting of the correct modulation for the actual baudrate is automatically made by the PTC-IIpro. The DSP PR modem is capable of full duplex and mixed baudrate in all modes.

The DSP concept for PR also allows the software setting and adjustment of all modem parameters. The output-level is set with the command **TXLevel1** (see chapter 9.6.38 on page 165) in the range of 20mVpp to 3Vpp. The adjustment of a potentiometer is not necessary.

The PTT-transistor is a powerful VMOS-FET which can reliably switch 16V at 1A to ground.

### 3 Installation

The input-sensitivity of the module can be chosen by the jumper J1. The initial condition of the jumper is closed. It can be found on the component location plan as a 0 Ω resistor on the left side of the PTT transistor Q1.

For 9k6 operation your transceiver requires a special connection. The modulation voltage is fed direct to the modulator, and the received signal is taken directly from the demodulator. Newer equipment sometimes offers a so called data connector. These “hybrid” radios are suitable for 9k6 operation without modifications. As the data connectors of all manufacturers have the same pin connections, **SCS** offers a special cable for use with these transceivers. Transceivers without a data connector require modification for direct access to the modulator and demodulator. Information concerning modifications can be found in practically all Packet-Radio mailboxes.

Here are the technical details:

Modulation	AFSK (Audio-Frequency-Shift-Keying) or FSK (Frequency-Shift-Keying)
AF output voltage	20 mVpp to 3Vpp adjustable. The output is muted while on receive.
Output impedance	approx. 1 kΩ
AF input	100 mVpp to 1.6 Vpp (J1 open) 100 mVpp to 8Vpp (J1 closed)
Input impedance	approx. 47 kΩ
PTT	max. 16 V, 1 A to GND

Table 3.19: Technical Details of the DSP-Module

#### 3.5.4 The AFSK Module

**This module is out of production and is replaced by the DSP-Module-II.**

The **SCS** AFSK-Module for Packet-Radio uses the standard baudrate 1200 and 2400 baud. The module uses the well known modem chip TCM3105, and is because of this fully compatible to the usual standards.

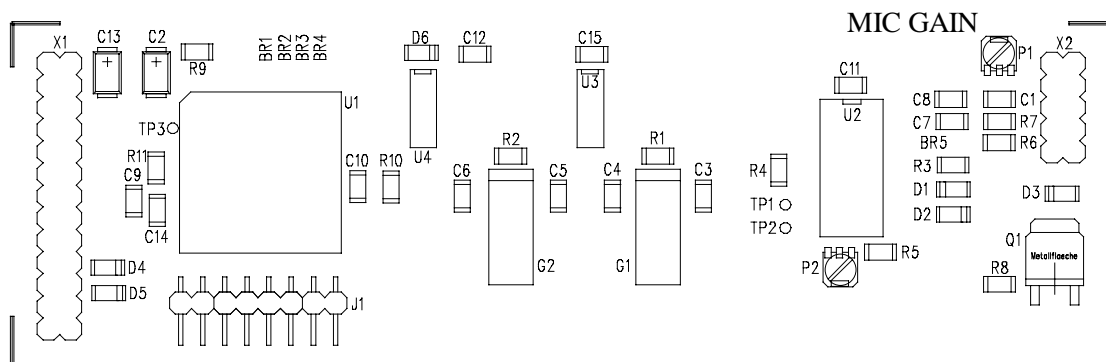

Figure 3.10: The 1k2/2k4 AFSK-Module.

## 3 Installation

The carrier detection is fully digital. This has the the advantage over the usual tone decoder circuitry in that (for example) a 1750 call tone is not detected as a signal. The module only reacts to Packet-Radio signals.

To make the carrier detection safe and fast, the squelch of the connected TRX shall be opened, that means that all the time signal noise is available at the AF output of the transceiver.

The module also contains a PTT watchdog that prevents a continuous carrier from being transmitted. A powerful VMOS-FET is used as the PTT switching transistor. This transistor can reliably switch even 16 Volts and 1 Amp to ground.

The AF output voltage can be adjusted with the potentiometer P1. It could be found on the circuit board, labeled as MIC GAIN as [Figure 3.10](#) shows. NOTE: the potentiometer does not contain an end stop, and is able to be turned through 360 degrees. The potentiometer is delivered set to its middle setting. The output voltage can be adjusted between 20 mVpp and 400 mVpp. By bridging over R7 it is possible to increase the output voltage to a maximum of 2 Vpp.

On delivery the AF input is adjusted for connection to a low level output (e.g. the demodulator output, a tapping point before the volume control or a data socket). By closing the link BR5, it is possible to lower the modules sensivity, and it may thus be directly connected to the loudspeaker of a transceiver. The volume should however not be turned up over normal *room* value.

Here are the technical details:

Modulation	AFSK (Audio-Frequency-Shift-Keying)
Tonepairs	1200/2200 Hz at 1200 Bit/s 2000/3666 Hz at 2400 Bit/s
AF output voltage	Approx. 20 mVpp to 400 mVpp adjustable. The output is muted while on receive.
Output impedance	Lower than 1 k $\Omega$
AF input	20 mVpp to 600 mVpp (BR5 open) 200 mVpp to 10 Vpp (BR5 closed)
Input impedance	Approx. 22 k $\Omega$
PTT	max. 16 V, 1 A to GND

Table 3.20: Technical details of the 1k2/2k4-Modul

### 3.5.5 The 9k6-Module

**This module is out of production ans is replaced by the DSP-Module-II.**

The **SCS** FSK-Module is fully G3RUH compatible. By using switched capacitor filters, the module can be used over a wide baudrate range without hardware changes. Although

### 3 Installation

the module has been especially developed for 9600 baud, it will work between 4800 and 38400 baud through the use of the SC-filter.

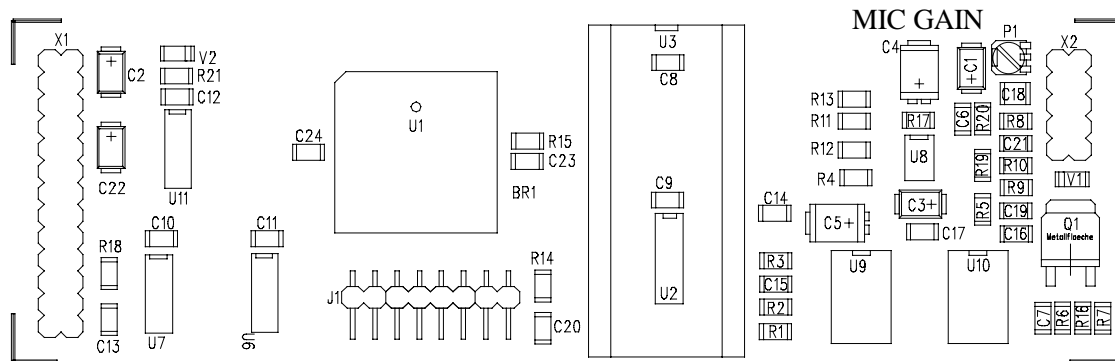

Figure 3.11: The 9k6-Module.

The module also contains a PTT watchdog that prevents a continuous carrier from being transmitted. A powerful VMOS-FET is used as the PTT switching transistor. This transistor can reliably switch even 16 Volts and 1A to ground.

The AF output voltage can be adjusted with the potentiometer P1, labelled as MIC GAIN as [Figure 3.11](#) shows. NOTE: the potentiometer does not contain an end stop, and is able to be turned through 360 degrees. The potentiometer is delivered set to its middle setting. The output voltage can be adjusted between 20 mVpp and 3Vpp.

For 9k6 operation your transceiver requires a special connection. The modulation voltage is fed direct to the modulator, and the received signal is taken directly from the demodulator. Newer equipment sometimes offers a so called data connector. These "hybrid" radios are suitable for 9k6 operation without modifications. But take care also with there radios. Due to the relatively high PLL stabilization time after TX/RX change, the **TXDelay** value has to be set significantly higher than with pure data-transceivers.

As the data connectors of all manufacturers have the same pin connections, **SCS** offers a special cable for use with these transceivers. Transceivers without a data connector require modification for direct access to the modulator and demodulator. Information concerning modifications can be found in practically all Packet-Radio mailboxes.

Here are the technical details:

Modulation	FSK (Frequency-Shift-Keying)
AF output voltage	Approx. 20 mVpp to 3Vpp adjustable. The output is muted while on receive.
Output impedance	Lower than 1 kΩ
AF input	100 mVpp to 3 Vpp
Input impedance	approx. 47 kΩ
PTT	max. 16 V, 1 A to GND

Table 3.21: Technical Details of the 9k6-Modul

### 3.5.6 The Packet-Radio connectors

The Packet-Radio connector on the PTC-IIpro is understandably only available when the appropriate modem is plugged in. The pin-out of the 5 PIN DIN socket follows usual TNC connections:

The 5 PIN DIN socket for Packet is connected as follows. (Viewed from the back of the PTC):

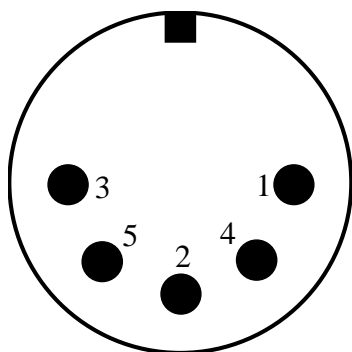

Pin 1: Audio output from the PTC to the transmitter.

Pin 2: Ground (GND).

Pin 3: PTT output.

Pin 4: Audio input from receiver to the PTC.  
(loudspeaker or appropriate AUX. connector).

Pin 5: Reserve.

Figure 3.12: Packet-Radio connector (5-PIN DIN)

PTC	Color
PIN 1	Violet
PIN 2	White
PIN 3	Yellow
PIN 4	Green
PIN 5	Blue

Table 3.22: Cable Colors: 5-pole DIN-cable

**NOTE:** The 5 PIN DIN socket is only available for use when an appropriate modem is inserted!

### 3 Installation

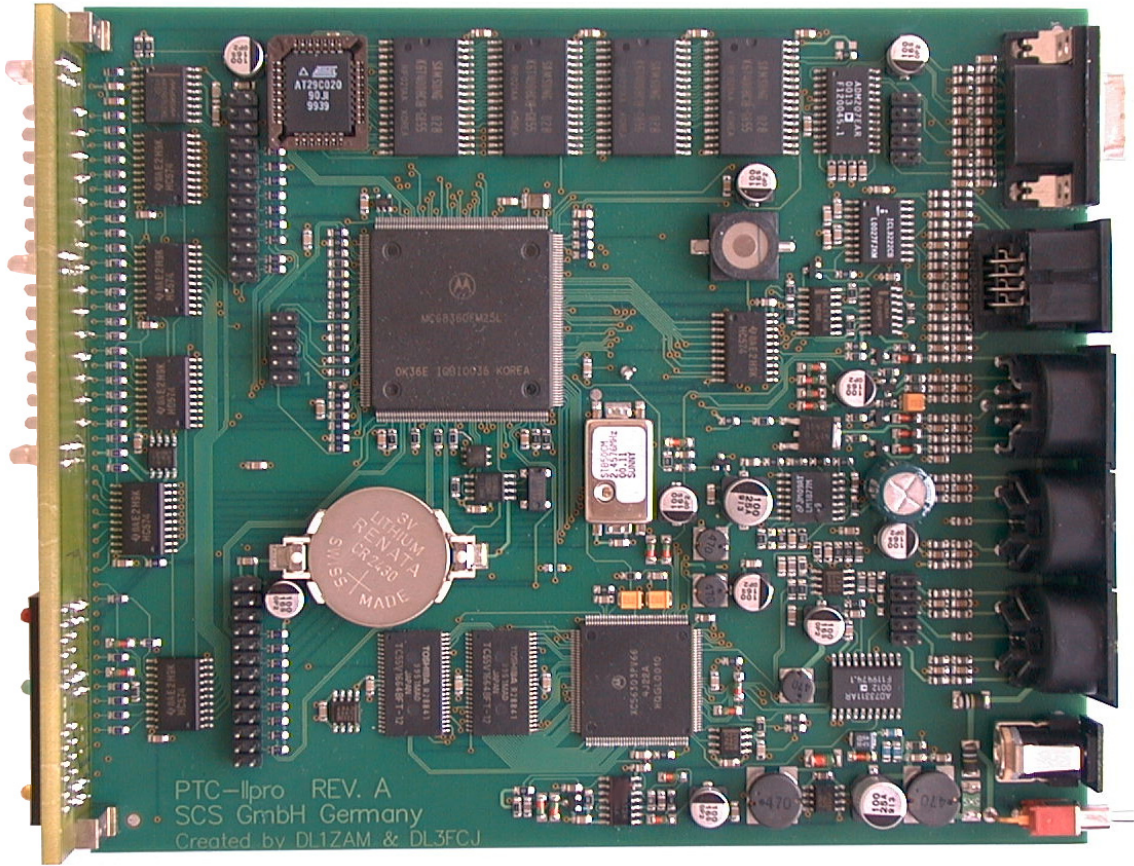

Figure 3.13: View of the PTC-IIpro

## Chapter 4

## 4 LED's

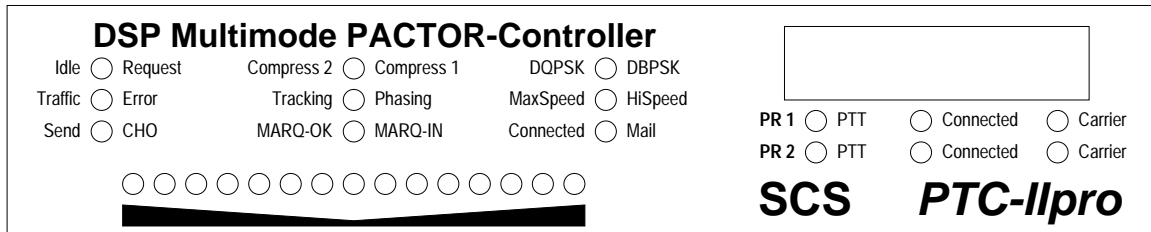

Figure 4.1: The PTC-IIpro front.

The **SCS** PTC-IIpro is equipped with 15 LED's to display the most essential status information, a fifteen LED tuning indicator and a ten character alphanumeric LED display to show the operating mode. The meaning of the LED's is shown below.

**Idle/Request:**

When Idle lights, then it means that at least one filler character (idle) is contained in the present packet. If Request lights, then the other station has requested a repeat of the last sent data or control packet.

**Traffic/Error:**

When Traffic is lit, then the system is transferring data, and the HF channel is uninterrupted. During the STBY condition, (not in Listen mode) then the Traffic LED shows when the channel is occupied (channel busy). If Error lights, then it means the packet or control signal had bit errors, and can therefore not be identified with certainty.

**Send/CHO:**

Send displays that the PTC is the actual packet sender. The CHO LED displays that at the moment, a change over (change of transmit direction) is being carried out. The CHO LED extinguishes when a change over is acknowledged by the other station.

**Compress2/Compress1:**

Displays which compression method is at present being used. Compress 1 is Huffman coding, Compress 2 being pseudo Markow coding. If the LED extinguishes, then the actual packet is an ASCII packet.

**Tracking/Phasing:**

Tracking lights for a short while when the PTC-IIpro changes the carrier frequency during a PT-II link (see also **AQrg** command in chapter 6.5, page 63). Phasing is active if a new phasing takes place in AMTOR (ARQ & FEC).

### **MARQ-OK/MARQ-IN:**

MARQ-OK lights if the actual packet has been correctly reconstructed using memory ARQ. MARQ-IN shows that the present packet is being reconstructed, and is not classed as a Request Packet.

### **DQPSK/DBPSK:**

These are activated respectively (also during Unproto and Listen mode) depending on if the packet is DQPSK or DBPSK.

### **MaxSpeed/HiSpeed:**

MaxSpeed lights during 16-DPSK packets (also with Unproto and Listen modes). HiSpeed lights during PT-I packets which are 200 baud (also with Unproto and Listen), and when PT-II packets using 8-DPSK are being used.

### **Connected/Mail:**

Connected lights permanently in the connected condition (AMTOR, PACTOR). In the STBY condition, Mail lights if there is unread mail for one's own address (MYcall callsign) in the PTC mailbox.

### **Tune:**

Under optimum conditions, only the two outermost LED's of the tuning indicator light up. With PACTOR-II the frequency offset is additionally displayed (center display LED) in red. In this case the middle of the tuning indicator is corresponding to the own frequency and the red LED in the middle represents the frequency of the distant station. If the middle indicator drifts to the left, the frequency of the distant station is too low. If the middle indicator drifts to the right, the frequency of the distant station is too high.

### **Matrix Display:**

The matrix display indicates the actual operating modes of the PTC-IIpro. For detailed information refer to table 6.1. Only the display of Packet-Radio connects needs more detailed information: The first digit indicates the used Packet-Radio port. **X** for port 1 and **Y** for port 2. The second and third digit indicate the channel the QSO ties up. The fourth digit indicates with the sign ^ (ASCII 94) a connection to the Packet-Radio mailbox. A . (ASCII 46) at the fourth digit indicates that there are unconfirmed packet at the PTC-IIpro.

At more than one connect the different channels are displayed in a 1.5 s alternating sequence.

## 4 LED's

Message	Description
Ready	The PTC-IIpro is in BIOS mode.
loading	The firmware is loaded from the Flash-ROM into the RAM.
---STBY---	The PTC-IIpro is in standby mode.
CON>DL6MAA	A connection to DL6MAA is build up.
C DL0HO	Reception of connect frames for DL0HO.
MON PT1	Monitoring of PACTOR.
MON PT2	Monitoring of PACTOR-II.
PT1 DL1ZAM	PACTOR connection to DL1ZAM.
PT2 DL6MAA	PACTOR-II connection to DL6MAA.
X01 DB0ZDF	Packet-Radio connection on port 1, channel 01 to DB0ZDF.
Y02 DB0AIS	Packet-Radio connection on port 2, channel 02 to DB0AIS.
Y02^DK9FAT	DK9FAT has connected the Packet-Radio mailbox of the PTC-IIpro.
Y02.BD0AIS	There are still packets for DB0AIS unconfirmed.

Table 4.1: Examples for the matrix display.

### PACKET

#### PTT:

The PR modem is keying the transmitter to send data.

The PTT-LED of port 2 has a special function. It blinks when the PTC-IIpro is in power-down condition initiated with the OFF command.

#### Connected:

The PTC-IIpro is linked to another station (Connected).

#### Carrier:

The modem has detected a valid Packet-Radio signal.

### PACTOR-III

Speedlevel	DQPSK/DBPSK-LED	MaxSpeed/HiSpeed-LED
1	red	-
2	green	-
3	-	red
4	-	green
5	red	green
6	green	green

Table 19: PACTOR-III Speedlevels

PTC-IIpro: The single LED in the tuning display shows the frequency error and lits red when the error is greater than 10 Hz. It lits green when the error is smaller than 10 Hz, which usually happens after the automatic frequency tracking has been completed.

## 4 LED's

For unlimited usage of PACTOR-III and the other extended features of the firmware you need a license key. Without this license key you just have 20 connects to test the extended features. Refer to the **LICENSE** command in chapter 6.47 on page 84.

For prices and a detailed manual for the extended firmware functions refer to the **SCS** homepage <http://www.scs-ptc.com> in the Internet.

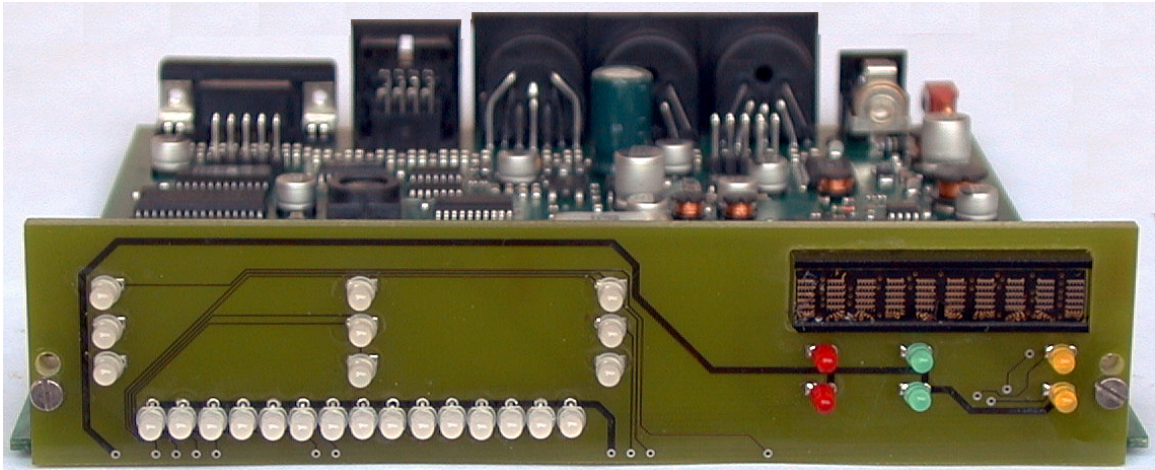

Figure 4.2: The PTC-IIpro front panel

## Chapter 5

### 5 PTC-Firmware

With the PTC-IIpro it is nearly possible to configure everything. In the manual always the default settings are assumed! If you have changed these settings you must keep this in mind while reading the manual. This is very important in case of the control characters which can be freely defined (CHANGEOVER character in chapter 6.19 on page 69, ESCAPE character in chapter 6.39 on page 80, BREAKIN character in chapter 6.12 on page 66 and the QRT character in chapter 6.79 on page 99).

#### 5.1 General

The operation of the PACTOR-Controller (PTC) takes place using commands which are sent over the serial interface. The data transfer format is: **8 data bits, 1 stop bit, no parity and half-duplex**. The baudrate is normally sensed automatically by the PTC. The PTC then acknowledges with **cmd:** and waits for a command. All commands and command strings are closed with <CR> (ASCII 13). <LF> (ASCII 10) is ignored during the command input. Working on the computer means you have to enter <Return>. Corrections can be carried out with *Backspace* (ASCII 8), above the <Return> key.

When in Standby, the **cmd:**-prompt is available immediately after the last command. The PTC is in the command mode. The command mode is displayed with the system prompt **cmd:** or **pac:**.

During link set-up and while connected the PTC is in the converse mode. Switching to RTTY or turning on the CW terminal also activates the converse mode. Whereas in the so-called converse mode, characters from the RS232 interface are placed in the transmit buffer and are sent over the HF channel at the next opportunity.

In Converse mode, commands to the PTC must be preceded with an ESCAPE character (initially set to <ESC>, ASCII 27). After each ESC character, only ONE command is accepted. After an invalid entry, however, the PTC immediately allows a new input. (The ESCAPE character, as well as the following command characters, DO NOT, of course, go into the transmit buffer).

During an Unproto transmission the output amplitude shall be modified.

Start unproto transmission

**cmd: U 1** <Return>

The PTC-IIpro starts the Unproto transmission and switches in the converse mode.

Clicking on <Esc> enables the command prompt **cmd:**. Now you can enter the command to change the output amplitude.

**cmd: FSKA 100** <Return>

Only this command is executed. The PTC switches immediately back to the converse mode. Now you can stop the Unproto transmission entering the QRT character.

<Ctrl> + <D>.

The PTC ends the Unproto transmission and changes to the command mode.

## 5.2 Command structure

PTC commands are similar to the commands of a TNC with *TAPR* software this makes it easy to learn and handle.

There are commands with and without arguments. If an argument is possible the argument has to be separated from the command by at least one space. A command's current argument setting is displayed if the command is entered without an argument.

Nearly all commands can be used in abbreviated form to save keystrokes. The shortest keyword of a command consists of the fewest number of characters that uniquely identify it, e.g. you may type **C** instead of **Connect**. All command inputs are internally converted to upper case, so both character shifts may be used. All commands are listed below, significant mnemonics are printed in capital letters. The short form of the **SERBaud** command is **SERB**.

## 5.3 Menus

The PTC-IIpro commands are combined into different function groups, so called menus. The different menus are the following:

- Packet-Radio
- Audio functions
- FAX/STTV
- Transceiver controlling
- System test

Last not least the *main* menu with the PACTOR/AMTOR/RTTY/CW/PSK31 commands. The command prompt indicates the menu you have already selected. The following table shows the prompts for the different modes.

Prompt	Menu
<b>cmd:</b>	Main menu
<b>pac:</b>	Packet-Radio
<b>aud:</b>	Audio functions
<b>fax:</b>	FAX/STTV
<b>trx:</b>	Transceiver controlling
<b>sys:</b>	System test

Table 5.1: Command prompts

The separated function groups are for a better overview but this is not their only reason. PACTOR for example has for the short wave port the command **TXDelay** and for the Packet-Radio port also the **TXDelay** command. The same is with the **MyCall** command for PACTOR and Packet-Radio.

The grouping of the commands within the menus allows to choose the right commands for the selected modes or functions.

### 5.4 Simultaneous STBY mode

In the STBY condition, the PTC automatically knows if it is called in AMTOR or PACTOR, answering in the respective mode. It is possible to use the **ARX** command to suppress the AMTOR reaction (In ARQ as well as FEC).

The **SCS**-PTC offers the possibility to receive AMTOR FEC and NAVTEX transmissions from the STBY condition. For this, the **BC** parameter must be set to 1. The reading of AMTOR FEC and NAVTEX can be inhibited with the **ARX** command, independently from **BC**.

### 5.5 Remote commands

Some PTC commands are also available for the distant station via the HF link. There are two control possibilities.

- First Setting: **REMOTE** 1 and **BOX** 0. With this setting, all remote control commands via the radio link must begin with a // sequence, and end with a CHANGEOVER. (e.g. //**Date** <Ctrl> + <Y> or //**Dir** <Ctrl> + <Y>).
- Second Setting: **BOX** 1, the BOX mode. With this setting, all remote control commands may be directly entered via the radio link, and terminated with a <Return>. (e.g. **LOG** <Return> or **Show** <Return>)

The commands for the PTC mailbox and for the gateway mode also belong to the remote commands.

Here is a list of all remote control commands:

<b>Command</b>	<b>Short description</b>	<b>Reference</b>
<b>BELL</b>	Call the Sysop.	Chapter <a href="#">6.11</a>
<b>Check</b>	Lists actual mails	Chapter <a href="#">6.17</a>
<b>CLr</b>	Erase the transmit buffer.	Chapter <a href="#">6.20</a>
<b>Connect</b>	Packet-Radio Gateway (Flexnet Style).	Chapter <a href="#">6.22</a>
<b>DAtE</b>	Calls up the PTC date.	Chapter <a href="#">6.33</a>
<b>DELeTe</b>	Erase a file or files.	Chapter <a href="#">6.35</a>
<b>DIR</b>	Read the main directory.	Chapter <a href="#">6.36</a>
<b>Gate</b>	Packet-Radio gateway.	Chapter <a href="#">6.43</a>
<b>Help</b>	Help !!	Chapter <a href="#">6.45</a>
<b>LISt</b>	Gives a list of files within a subdirectory.	Chapter <a href="#">6.49</a>
<b>LOg</b>	Calls up the PTC log book.	Chapter <a href="#">6.52</a>
<b>LOGIn</b>	Log in for AMTOR.	Chapter <a href="#">6.53</a>
<b>Phase</b>	Calls up phase information.	Chapter <a href="#">6.72</a>
<b>POSition</b>	Requests GPS position	Chapter <a href="#">6.73</a>
<b>Qrt</b>	Starts QRT.	Chapter <a href="#">6.78</a>
<b>Read</b>	Reads a particular file.	Chapter <a href="#">6.80</a>
<b>RESEt</b>	Resets the PTC (without loss of MBX data).	Chapter <a href="#">6.83</a>
<b>Send</b>	Sends a particular file.	Chapter <a href="#">6.108</a>
<b>SHoW</b>	Calls up QSO statistical data and PTC settings.	Chapter <a href="#">6.89</a>
<b>TIme</b>	Calls up the PTC clock time.	Chapter <a href="#">6.95</a>
<b>TRX</b>	Transceiver control.	Chapter <a href="#">6.99</a>
<b>User</b>	Shows the current users.	Chapter <a href="#">6.104</a>
<b>Version</b>	Calls up the PTC software version.	Chapter <a href="#">6.107</a>
<b>write</b>	Writes a file into the PTC Mailbox.	Chapter <a href="#">6.108</a>

Table 5.2: Remote commands

In addition, all remote control commands are identified with the word `Remote` in the table of contents and command description in this manual. (refer also to chapter [6.82](#), page [100](#)).

## 5.6 PTC-Mailbox

The PTC contains its own built-in mailbox. The mailbox files are stored in static RAM and remain there even when the power supply is turned off. The maximum allowable file length and the number of files in the mailbox is only limited by the amount of free memory. The memory can be expanded up to 2 MByte. Filenames may be a maximum of 10 characters long, and should contain no special characters. The PTC truncates all over long filenames after 10 characters, no difference being made between upper and lower case letters.

Entering the Help command via PACTOR the mailbox of the PTC-IIpro displays the following list.

```

<factor remote commands>

h(elp)      q(rt)      da(te)     ti(me)
d(ir)      w(rite)   r(ead)     del(ete)
sh(ow)     v(ersion)  p(hase)    lo(g)
c(heck)    c(onnect)  cl(r)      l(ist)
s(end)     be(ll)     trx        g(ate)
rcu        us(er)   pos(ition)

characters within brackets are optional.
For more information type: h command (eg: help send).

next?

```

Display 5.6.1: PACTOR mailbox help

At Read and Send commands (on the terminal side) without a file number, either the first file will be read, or, if more than one file is present, the directory will be shown. When no argument is given, then the present directory name (path) will be used by the file system.

BREAKIN during a remote text output (also while reading a file) will erase the text output or ends the file read.

After a **Disconnect**, **RESEt** or **REStArt**, the current directory is set to the **MYCALL** given value. With a connect from another station (Slave connect), the current directory is set to the call of the other station.

Valid **Write-**, **List-**, **Read-**, or **DELeTe** commands set the path to the given directory. (The directory name must naturally be explicit in the argument).

A list of the commands follows:

Command	Short description	Reference
<b>Help</b>	Help !!	Chapter <a href="#">6.45</a>
<b>BEll</b>	Call the Sysop.	Chapter <a href="#">6.11</a>
<b>Dir</b>	Read the main directory OF THE MAILBOX.	Chapter <a href="#">6.36</a>
<b>List</b>	Gives a list of files within a directory.	Chapter <a href="#">6.49</a>
<b>Check</b>	Lists actual mails	Chapter <a href="#">6.17</a>
<b>Read</b>	Reads a Mail.	Chapter <a href="#">6.80</a>
<b>Write</b>	Writes a mail into the PTC Mailbox.	Chapter <a href="#">6.108</a>
<b>Send</b>	Sends a mail.	Chapter <a href="#">6.86</a>

Command	Short description	Reference
<b>DELeTe</b>	Erase a mail.	Chapter 6.35
<b>USer</b>	Shows the current users.	Chapter 6.104
<b>LOg</b>	Calls up the log book.	Chapter 6.52
<b>Qrt</b>	Leaves mailbox, alternative the command BYe.	Chapter 6.78
<b>Gate</b>	Packet-Radio gateway.	Chapter 6.43
<b>Version</b>	Calls up the version.	Chapter 6.107
<b>CLr</b>	Erase the transmit buffer.	Chapter 6.20
<b>DAte</b>	Calls up the date.	Chapter 6.33
<b>TIme</b>	Calls up the clock time.	Chapter 6.95
<b>SHow</b>	Calls up QSO statistical data.	Chapter 6.89
<b>Phase</b>	Calls up phase information.	Chapter 6.72
<b>POStion</b>	Requests GPS position	Chapter 6.73
<b>TRX</b>	Transceiver control.	Chapter 6.99

Table 5.3: PACTOR mailbox commands

Of course it is possible to enter mailbox commands on the console. With the **DIR** and **List** command you can check the mailbox contents. **Write** saves the mail, with **Read** you can read the mail and with **DELeTe** you can delete the mail.

### 5.6.1 Multiple file operations

All commands that contain a file number in the argument (e.g. **DELeTe** or **Read**) allow batch access. File numbering is indicated in the format start-end.

**DEL** test 1- entire directory named 'test' is erased

**R** 2-4 read file numbers 2 to 4 of the present directory

**Dir** 4- lists the files in the present directory from no. 4 till the *last file*

### 5.6.2 Special features when reading files

When a remote station is reading out a file in PACTOR the PTC checks if the file has been written in AMTOR. Next of all it is checked if it only contains capital letters. If yes, then the PTC converts the file contents into lowercase letters, which can lead to almost doubling of the transmission speed in PACTOR, due to more effective Huffman coding.

### 5.6.3 The PTC mailbox for Packet-Radio

Up to four PR (Packet-Radio) users may be simultaneously connected in PR to the PTC-mailbox. There they may read files, write files and delete files. In addition, the PTC-IIpro allows a further user simultaneous access to the internal mailbox via Pactor I/II or AMTOR. Virtually unlimited access is thus allowed to the same *data pool* via PACTOR/AMTOR and PR. This result in an increased data transparency at the HF/VHF interface, allowing an easier direct transfer of data between HF and VHF users. This property of the PTC-IIpro allows it's use as a powerful and flexible personal (private)

*maildrop*. It is also possible to use it in smaller general mailbox systems as a *stand-alone* solution.

The PR mailbox in the PTC-IIpro can be viewed as a self contained *TNC in the PTC*. This *virtual* mailbox TNC contains its own callsign, the BBS-MYCALL. The user can reach the PR mailbox in the PTC-IIpro by connecting to the BBS-MYCALL of the PTC-IIpro. The BBS callsign is set automatically to MYCALL-8, either at the first start (when the *Flash-Call* in the BIOS has been defined, or when ones own PACTOR-MYCALL has been set.

If, for example, DL1ZAM is given as the first PACTOR-MYCALL then the PR-mailbox can be connected to under the callsign DL1ZAM-8. The BBS-MYCALL callsign of the PTC can be changed or checked thereafter at any time with the **MYMail** command in the **pac**:-menu.

To change the setting of the PR-box characteristics, there are three commands in the **pac**:-menu: **PRBox**, **MYMail** and **MText**.

### 5.6.4 Practical operation using the PR mailbox

After a Help command, the PR mailbox of the PTC-IIpro displays the following list:

```
PTC-IIpro Mailbox Help
```

```
-----
```

Bell	Check	Date	Dir	Erase	Gate
Help	List	LOg	POStion	Quit	Read
Send	Time	TRX	User	Version	

```
Type "Help command" for detailed information.
```

Display 5.6.2: PR mailbox help

These are the commands available for PR. They behave, with few exceptions, exactly as those for PACTOR. A few commands also allow an alternative input, and so the command interpreter understands **Write** instead of **Send**, **Bye** instead of **Quit** and **DELeTe** instead of **Erase**.

There is a special small help text available for each command, which the user can call up with **Help** followed by the appropriate command. E.g. **Help Send** <Return>.

Command	Short description	Reference
<b>Help</b>	Help !!	Chapter
<b>BEll</b>	Call the Sysop.	Chapter <a href="#">6.45</a>
<b>Dir</b>	Read the main directory OF THE MAILBOX.	Chapter <a href="#">6.36</a>
<b>List</b>	Gives a list of files within a directory.	Chapter <a href="#">6.49</a>
<b>Check</b>	Lists actual mails	Chapter <a href="#">6.17</a>
<b>Read</b>	Reads a Mail.	Chapter <a href="#">6.80</a>
<b>Send</b>	Sends a mail, alternative the command <b>Write</b> .	Chapter <a href="#">6.108</a>
<b>Erase</b>	Erase a mail, alternative the command <b>DElete</b> .	Chapter <a href="#">6.35</a>
<b>User</b>	Shows the current users.	Chapter <a href="#">6.104</a>
<b>LOG</b>	Calls up the log book.	Chapter <a href="#">6.52</a>
<b>Quit</b>	Leaves mailbox, alternative the command <b>BYe</b> .	
<b>POSition</b>	Requests GPS position	Chapter <a href="#">6.73</a>
<b>Gate</b>	Packet-Radio gateway.	Chapter <a href="#">5.11</a>
<b>Version</b>	Calls up the version.	Chapter <a href="#">6.107</a>
<b>DAte</b>	Calls up the date.	Chapter <a href="#">6.33</a>
<b>TIme</b>	Calls up the clock time.	Chapter <a href="#">6.95</a>
<b>TRX</b>	Transceiver control.	Chapter <a href="#">6.99</a>

Table 5.4: Packet-Radio mailbox commands

Every text output from the PTC-IIpro PR mailbox is ended with a *Prompt* which is identical in format to many mailbox systems (present directory in brackets followed by the user callsign and mailbox callsign. E.g. : **(TEST) DL6MAA de DL1ZAM>** .

The present directory is automatically changed with the usage of the read-, write- and list-commands.

Mailbox *Batch* access, (e.g "**Read** 1-") is also available on PR.

7PLUS files can be read from, and written to, without problem. AUTO-BIN-transfer or similar protocols are at present not supported by the PR mailbox.

Uppercase and lowercase letters are not distinguished in the command processing. All commands can be more or less abbreviated. The maximum abbreviation possible can be found in the help text. Only the letters written in capitals must be typed for the command to be correctly understood.

PR mailbox links occupy as is *usual*, the lowest free channel of the PTC-IIpro. The terminal program also displays the usual *connect message* when a *mailbox connect* is made, with however, the addition " (**BBS-Connect**) ".

Local text input from the terminal to channels already occupied with BBS connects are ignored. It is however, always possible for the Sysop to disconnect an existing BBS connection by giving a disconnect command via the local terminal.

Received text is displayed in hostmode terminal programs (e.g. **GP**) exactly as usual and can be followed by the Sysop. The Sysop can hereby notice which commands are given by the users. In terminal mode, the text output from the BBS channels are completely suppressed to prevent that the PTC-IIpro receives buffer filling and maybe overflowing.

## 5.6.5 Passing PR connects to the mailbox

The **Users** command in the **pac:-**menu allows any incoming PR connect to be passed over to the PTC-IIpro PR-mailbox. To do this **Users** has to be set to 0. This will allow for example, that on leaving the terminal program, (e.g. automatic de initialising with **Y0** in **GP**) the PTC-IIpro can be brought to a condition where a connect using the *normal MYCALL* (i.e. without the -8) will be transferred to the mailbox. This is useful, as many potential users would use the *normal MYCALL* to connect to the PTC-IIpro.

If the terminal is *off-line*, and the configuration is correct, (**Users** 0 or **Y0**) then all calls, irrespective they are the *normal MYCALL*, the *MYALIAS*, or the *BBS-MYCALL*, will be transferred to the PTC-mailbox.

## 5.6.6 Properties of mailbox-commands

### Send

Text input can either finished with <Ctrl-Z> or with **\*\*\*end**, as well known from other mailbox systems. The **NNNN** sequence has no effect in PR !

Files that have been input via PR are signified in the status display (**ST**), the **List-** and **CHeck-** outputs by being marked with an X (**AX.25**), e.g: .... **NX DL2FAK** ...

The mail LED starts to blink when a file is written via PR whose filename is the same as the **MYCALL** of the PTC-IIpro for channel 0.

### Read

Even during a file read operation, it is possible to give further commands to the PTC mailbox. These commands are stored in a buffer, and only acted upon when the relevant file read operation is complete. An empty input (only <Return>), interrupts the file read operation.

### User

Lists the presently active links, similar to the **CStatus** command in the **pac:-**menu. A presently active PACTOR link is displayed in channel 0 of the list and in addition marked with the comment **PACTOR**. Every active link with the PTC mailbox is displayed with the callsign of the connected station, together with the appropriate digipeater list.

PR links that are not connected to the PR-Box are displayed as a so called *NON-BBS-CONNECT*, without however, the callsign of the opposite station.

## 5.7 The NAVTEX-Processor

### 5.7.1 NAVTEX General

The NAVTEX service, introduced a number of years ago as part of the GMDSS (Global Marine and Distress Safety System), is a maritime news service, broadcasting weather, navigational and safety information to shipping. This gives the impression that the system

uses the most modern technology. In fact, underneath the impressive sounding name, is nothing other than a network of marine coast stations that

broadcast plain language messages using the SITOR-B system, at specific times. This system is known to amateurs as AMTOR mode B or FEC. It uses the usual 170 Hz FSK modulation system, which is also an old and wide spread system in HF digital radio. For NAVTEX, only one MF channel on the frequency of 512 kHz has been allocated. The transmission range is approximately 800 km. A range limitation is an essential part of the system so that reliable time sharing of the one frequency between the various coast stations is possible. It is basically possible to decode NAVTEX using any AMTOR modem, however, it has proved in practice, that just reading the transmissions has a number of disadvantages, and is therefore not of great value.

In the flood of messages sent, without pre-selection and a form of buffer memory, it is very likely that the "interesting" messages will be lost.

The messages are sent more than once, the newer ones at least every 4 hours, the older ones at longer intervals. As SITOR-B is very prone to errors when signals are weak, the receiver should ensure that only the best copy of the message to date is stored, and available for the Radio Officer or Navigator. This is totally impossible by just "reading the mail".

As NAVTEX works on long waves, the reception is generally better at night than during the day. When sunny, the electrical energy requirements of small ships can be met by solar panels. At night this is not possible. The noise of a generator is also not exactly customised to enhance the sleep of the crew. The power requirements at night should thus be kept as low as possible. A continuously running laptop or other computer is a relatively large load for the energy supply of a small ship. A NAVTEX controller should therefore be able to operate without any additional computer, and use little electrical energy itself.

The NAVTEX processor of the PTC-IIpro solves many of the disadvantages mentioned above. It enables:

Automatic, selective reading of NAVTEX transmissions. Either the code for the type of message or the regional code can be selected.

Automatic processing of transmissions received more than once. Only the best copy is held. Old data is automatically deleted.

A fast check on the type of received messages.

A memory buffer is available without using an external computer, as the NAVTEX processor uses the PTC-IIpro internal mailbox as a message store. It automatically lays down, if not already there, a subdirectory called NAVTEX in the PTC-box. Data written into the mailbox by the NAVTEX processor can be accessed via PACTOR or Packet-Radio.

### **5.7.2 The NAVTEX System in Detail**

As mentioned above, NAVTEX messages are sent in plain language using SITOR-B coding. To mark the beginning, end, and type of message, NAVTEX uses a simple convention.

Every message begins with the characters ZCZC, followed by a space. Then follows the four figure message identifier plus a carriage return. The actual message now follows.

Every message finishes with NNNN. (If these end characters are mutilated, the NAVTEX-processor finishes writing the message at the latest after loss of receive synchronisation).

The message identifier is constructed as follows:

The first character is a letter, with a range of A to Z. This letter sets the area code and is allocated to one transmitter in the reception area. Which letter is allocated to which transmitting station can be seen relatively fast, as the transmitting station is usually also mentioned in the message itself.

The second letter describes the type of message. The following types are presently defined:

- A: Navigational Warning
- B: Meteorological Warning
- C: Ice Report
- D: Search and Rescue Info
- F: Pilot Message
- G: DECCA Message
- H: LORAN-C Message
- I: OMEGA Message
- J: SATNAV Message
- K: Other NAV aid system Msg
- L: Navigational Warning (2)

The next two places in the message identifier contain the message number. This number belongs to a message of a particular type and remains unchanged when a message is transmitted more than once. The numbers are consecutive. The number has a decimal format and comprises 00 to 99. If an overflow occurs, i.e. "started" again at 00, then usually, the "old" 00 message is no longer active, and permission to erase has been granted, or has already automatically been erased by the NAVTEX processor. This is naturally valid for all numbers in consecutive operation. An exception can occur in the very numerous "Navigational Warning" messages. That is why there are two different message type letters, A and L, which actually describe the same type of message. This trick allows the possible number of active "Navigational Warning" messages to reach 200.

### 5.7.3 Operating the NAVTEX Processor

The NAVTEX processor has only a single new command in the **cmd:-**menu. This is **NAVtex**. This command allows the complete configuration and activation of the automatic NAVTEX processor. It operates in the background, as a completely separate process within the PTC-IIpro multitasking environment.

When activated, the NAVTEX processor lays down a directory with the name NAVTEX in the PTC-IIpro mailbox, and stores all incoming NAVTEX messages there. The name of the message author is given as "AUTO-NAV". The NAVTEX processor gives the complete four figure message header as well as the plain language name of the type of message. E.g. "CA03 Navigational Warning".

The PTC-IIpro displays the message **AUTO-NAV** on the green alphanumeric display whilst message storage is taking place. If the number of messages in the NAVTEX directory exceeds the maximum allowed, the NAVTEX processor deletes the oldest message it has previously stored before starting to store a new message. (Messages from other sources which may also be in the NAVTEX directory - such as operating instructions - are NOT deleted!). For details on the **NAVt<sub>ex</sub>** command refer to chapter 6.66 on page 91.

### 5.7.4 Notes about NAVTEX practice

The PTC-IIpro normally operates with 200 Hz shift for FSK operation. Although NAVTEX uses 170 Hz shift, it is not necessary to change the modem tone settings for NAVTEX reception. The loss due to the slightly maladjusted shift being in the area of tenths of a dB, and can be ignored for practical purposes.

When using the usual modem tones of 1400 Hz and 1200 Hz (Low-tones, **Tones** parameter 0), the receiver should be set to USB and a frequency of 516.700 kHz to receive NAVTEX on a center frequency of 518 kHz. For LSB the frequency should be set to 519.300 kHz. Here, the **TR** parameter should be set to 1 or 3 (See handbook).

Basically, the same conditions for NAVTEX reception are required as for AMTOR-FEC. The parameters **BC** and **ARX** must both be set to 1. (these are the default values. Refer to section 6.10 on page 66 and section 6.6 on page 63).

### 5.7.5 AMTEX

The American Radio Relay League (ARRL) has used one system (among others) for its radio bulletins via HF radio for a number of years, which closely resembles the maritime NAVTEX system, and follows the same protocol rules. It is called AMTEX. This amateur radio NAVTEX differs only in its special definition of possible message types, which have been adjusted for amateur radio usage. The existing NAVTEX processor in the PTC-IIpro is thus very suitable for fully automatic reception of AMTEX transmissions, provided suitable adjustments are made. The messages are transmitted (as with NAVTEX) in AMTOR FEC ("mode B") normally from 1800 and 2100 American local time (i.e. 2300 and 0200 UTC - or one hour earlier during summer time). The AMTEX transmissions take place on the frequencies of 3625, 7095, 14095, 18102.5, 21095 and 28095 kHz (Mark). The following message types have been defined to date:

E:	DX News Bulletin
G:	General News Bulletin
K:	Keplerian Data Bulletin
P:	Propagation News Bulletin
S:	Space Bulletin
X:	Special Bulletin

Table 5.5: AMTEX message types

Generally, "A" is used as the area code (Station ident). Exceptionally, "S" has been used.

## 5.8 GPS

The "Global Positioning System" (GPS) has very quickly become a standard for all areas that require exact positional information e.g. shipping, in-car navigation systems etc. Today, GPS receivers are cheaply available and widely used. The PTC-IIpro offers the possibility to link the GPS technology with PACTOR, and also to PR. It now becomes possible for example to call up the present position of small ships or deep sea yachts via shortwave, without requiring a PC to be running on the mobile station and without a ships radio operator.

**SCS** offers a special Y-cable which which devides the wires from and to the serial interface of the PTC-IIpro into two parts, so that 2 separate RS232/V24 connections with SUB-D sockets are created (refer to chapter 17 on page 241). With the help of the Y-cable now both, computer and GPS-receiver can be connected to the PTC-IIpro.

### 5.8.1 Connecting the GPS receiver

The GPS receiver must be connected to the secondary serial port of the PTC-IIpro. The input and output of the secondary port is brought out to the normal SUB-D plug of the RS232 interface, and is available from there.

The secondary port input is connected to pin 4 of the RS232 socket. The secondary port output is connected to pin 9 of the RS232 socket. (Ground is connected to pin 5. Do not forget the ground connection!)

SCS offers a special Y cable which splits the leads to and from the RS232 socket on the PTC-IIpro so that two separate DIN-9 RS232 standard sockets are available. By using the Y cable, it is possible to connect a GPS receiver and a PC to the PTC-IIpro without needing a soldering iron. Refer to chapters 16 page 229 and C4 on page 253 for details.

GPS receivers normally work at a speed of 4800 Bd from their serial NMEA output. The PTC-IIpro normally operates automatically at 4800 Bd on its secondary serial port.

If both PR sockets are occupied with a modem, then there is no free baudrate generator available. In this case the PTC-IIpro uses the baudrate of the TRX port for the secondary serial port. (Most transceivers can be set to 4800 Bd for remote control. The typical 4800 Bd for the GPS receiver can be set using the TYPe command in the trx:- menu, without having to sacrifice the TRX remote control ability.)

Some GPS receivers offer various protocolls for control via the serial port. The PTC-IIpro expects a NMEA compatible GPS receiver. The GPS equipment must therefore be set to "NMEA compatible"!

### 5.8.2 GPS position request

As soon as a GPS receiver is connected, the PTC-IIpro evaluates the incoming data and saves the actual position with the corresponding (GPS) time.

The PTC-IIpro accepts messages in formats GPRMC, GPGLL, IIRMC and IIGLL. RMC has priority over GLL.

The user can call up this position data with the **POSition** command in the **cmd:-** menu. The **POSition** command is also a remote control command, and available for use via PACTOR and PR. It can also be called up by users of the PTC-box.

Hostmode programs can use the channel 249 to directly access the NMEA data of a connected GPS receiver (refer to chapter 10.8 on page 184).

### 5.9 APRS<sup>1</sup>

APRS (Automatic Position Reporting System) was developed 1992 from Bob Bruninga (WB4APR) as a special operating mode of Packet-Radio, as the name implies, for automatic transfer of position data.

APRS is mainly used for tracking of mobile *objects*. For that the actual position is read out from a GPS receiver (“GPS” operation). But also without GPS receiver connected *fix* position data can be transmitted (“FIX” operation). In this case the position needs to be entered manually.

The PTC-IIpro operates this mode stand alone and without being connected to a PC!

To setup the APRS features the command **APRS** in the **pac:** -menu is available (refer to chapter 9.6.1 on page 150). Also here the parts of the commands written in capital letters are necessary to enter to invoke the command. The first argument following the **APRS** command usually acts as a sub-command and selects a function. The final parameters are defined with the arguments following this sub-command. If there is no sub-command given and the numeric parameter follows directly to the **APRS** command, then this parameter defines the APRS main mode.

APRS digipeating is not supported directly, but the normal digipeating features can be used for *simple* APRS digipeating as well. An universal APRS digipeater can also be established using a free program like UI-View.

APRS data is always transmitted using the modulation defined with the command **Baud** (or **%B** in hostmode), (refer to chapter 9.6.2 page 154 and 10.4.25 page 177).

### 5.10 Robust HF-Packet

Up till now Packet-Radio over shortwave has been basically a non-starter, has even been heavily criticized because of the low effective throughput and many repeats due to missing robustness. AX.25 is for shortwave not an ideal protocol, but with automatic **FRack** setting and a small **MAXFrame** value the protocol should however function much better on a shortwave channel than has previously been the case generally.

One cannot of course expect an asynchrone protocol to reach the same efficiency as a small synchrone ARQ protocol (e.g. PACTOR), but for some applications a multi user service with very uncritical transmit/receive switching, as well as almost zero power holding up a connection when no data passing, brings a real advantage that outweighs the lower data throughput.

What are the reasons then, that up until now HF-PR works so poorly, and apart from “forwarding” is hardly ever used? There is a simple answer: The current modulation type for HF-PR namely uncoded 300 baud FSK is really unsuitable for normal HF channels.

---

<sup>1</sup> APRS is registered Trademark of the APRS Engineering LCC, USA

The symbols are much too small even with moderate “multi path effect” (“delay spread”) to work. Additionally because no sort of error correction code is used, even short troughs or “statics” will destroy a many seconds long packet. Just one missing bit leads to a repeat of the whole transmission.

To overcome this problem **SCS** has developed a new class of robust modulation types especially for Packet-Radio. As a special feature for all the variants of this “Robust-PR” a completely new synchronization algorithm with tracking properties that were not possible before has been realized. **Frequency deviations of  $\pm 250$  Hz are immediately recognized and compensated without any loss of sensitivity**, and this also with signals that are buried deep in the noise. Because of this it is possible to remove a tuning display. One can say with good conscience this is “Plug and Play” for shortwave.

The 3.6 firmware makes available a small band (500 Hz) version of the “Robust-PR”. A wide band variant (2 kHz) with similar characteristics and 4 times the speed is in generally possible.

The current “Robust-PR” modulations schemes have the following characteristics:

Bandwidth:	500 Hz @ -30dB.
Modulation:	Pulse-Shaped OFDM (BPSK, QPSK); similar to Pactor-III
Average throughput:	200 or 600 Bits/s (Increase to 1200 Bit/s possible)
Crestfactor:	3.0 or 4.2 dB
Delay-Spread:	to $\pm 8$ msec can be coped with
Coding:	High performance error correction code, “full-frame interleaved”, rate/2 or rate 3/4

### 5.11 The PR $\rightarrow$ PACTOR Gateway

The PTC-IIpro provides the outstanding featurwe to establish a PACTOR connection on short wave using Packet-Radio(!) To utilize this feature in a perfect way, the following requirements have to be fulfilled:

1. The controller must be able to control the frequency of the HF radio independently, without the need of being supported by a PC for this purpose.
2. The controller must be able to determine by itself in a very reliable way if a HF channel is already occupied, to prevent mutual interference.

The PTC-IIpro fulfills both requirements: A TRX control port and a special DSP algorithm for *channel busy* recognition.

To ensure a simple and safe operation of the gateway at link establishment the PTC-IIpro uses the frequency data as well as other information of the TRX frequency list. The gate parameter included in the frequency list determines whether a defined channel is enabled or disabled for PR  $\rightarrow$  PACTOR gateway operation.

This is a typical TRX frequency list:

```

CHANNEL-LIST:
=====
Ch      Frequency (kHz)  Scan   Gate   Comment
-----
1:      3583.650         YES    NO     dl1zam channel 1
2:      3585.650         YES    NO     DL1ZAM channel 2
3:      3584.000         YES    YES    Test QRG DL1ZAM
4:      14079.000        NO     YES    DL2FAK CN2SM
5:      14076.540        NO     NO     EA5FIN's summer QRG
6:      14075.600        NO     YES    LA2MV
7:      14080.000        NO     YES    9K2EC special
8:      3587.000         YES    YES    SM3HUA QRG
9:      3595.400         NO     YES    DJ9YJ QRG
10:     3588.000         NO     YES    DKOMAV HB9AK
11:     14077.000        NO     YES    second ch dl2fak

*** WARNING: YOUR CALLSIGN WILL APPEAR ON HF/SHORT WAVE!
*** PLEASE DO NOT USE THE HF-GATE WITHOUT HF-LICENSE!

```

Display 5.11.1: Typical frequency list

The list can be generated with the **Channel** command in the **trx:-**menu, refer to chapter [13.1](#), page 199.

To access to the PR→PACTOR gateway is only allowed for persons that own a valid license to operate on HF bands. The callsign of the gateway user is displayed without additional remarks on short wave! (An extension, e.g. DL2FAK-4, would cause trouble with most of the PACTOR mailbox systems). Access limits can be defined with the help of the Xuser command.

### 5.11.1 TRX command

The **TRX** command allows the standardization of the syntax in comparison to the PACTOR port. After entering **TRX** List (List needs not o be entered) a **TRX** frequency list is displayed, the same as on the PACTOR port.

### 5.11.2 Gate command

The **Gate** command is the fundamental command for the usage of the PR→PACTOR gateway. It provides several options:

Entered with no argument the PTC-IIpro displays the TRX frequency list.

If the argument is a callsign, e.g. **G** DL2FAK <Return>, the PTC-IIpro attempts to establish a gateway connect to DL2FAK on shortwave.

For this purpose the system browses through all comment fields with enabled Gate parameter of the frequency list (starting with channel 1) for the callsign (case insensitive). The end of a callsign in the comment field can be marked with any *non-alphanumeric* special character, e.g. with a space, comma or something else.

The search mechanism compares the number of characters entered as the arguments of the **Gate** command. If e.g. **G** DL2FA is entered, the length to be checked for is defined to be 5 characters. The callsign *DL2FA* will not be found in the TRX list although DL2FAK is present in two of the comment fields. The following character behind *DL2FA* in the comment field is a *K*, which represents an alphanumeric character (letter or number), so that the search algorithm *notices* that this can't be *DL2FA*. If, e.g. DJ9YJ/M is contained in one of the comment fields, the search algorithm will detect the right channel when entering **G** DJ9YJ as well as when entering **G** DJ9YJ/P.

Back to the example of **G** DL2FAK – The PTC-IIpro first of all will find this callsign in the comment field of channel 4. The appropriate frequency is 14079 kHz. The system now sends this frequency formatted as remote control command to the transceiver using the TRX port. It checks every 5 seconds if the indicated frequency is already occupied and if free it calls for DL2FAK in PACTOR mode. The maximum calling time is limited on 1 minute for not to occupy the frequency more than necessary.

A typical sequence send for the procedure discussed above is:

```
*** QRX - CHANNEL BUSY TEST ON: 14079.000 kHz

*** LINK SETUP ON HF / PACTOR...

*** CONNECTED TO DL2FAK
```

### Display 5.11.2: PR→PACTOR gateway message while building a connection

The connection can now be operated in the same manner as in PR, provided that the PACTOR station performs the CHANGEOVER selfcontrolled after having transmitted the text, but that's usual for all mailbox systems as well as for the PTC-IIpro PACTOR box (Problems with the CHANGEOVER of the PR→PACTOR will be discussed later on).

The connect will be terminated if either the gateway user disconnects the PR connection or the connected PACTOR station disconnects the PACTOR link, e.g. after the **Q** command is entered by the gateway user to request the disconnect by the distant station. In this case the command prompt of the PTC-PR box will be displayed, ready to accept new commands, e.g. another gateway command.

The PACTOR connection established by a gateway command will be terminated

automatically if the link is inactive for 10 minutes.

If the HF port is occupied when entering the **Gate** command the PTC indicates this with displaying the following message:

```
*** BUSY fm HF-GATE

*** TRY AGAIN LATER...
```

Display 5.11.3: PR→PACTOR gateway message if the HF port is occupied.

If the system notices at checking the HF channel that it is already occupied, the following message is displayed:

```
*** QRX - CHANNEL BUSY TEST ON: 14079.000 KHZ

*** HF CHANNEL ALREADY OCCUPIED!
```

Display 5.11.4: PR→PACTOR gateway message if the channel is occupied.

In this case the system automatically resumes browsing through the comment fields, searching for the given callsign. In the example the PTC-IIpro will find the callsign DL2FAK again in channel 11 and tries again to establish a PACTOR connection if the channel is not occupied.

If the callsign does not appear anymore in the TRX list, the system stops activity.

**Note:** If the longpath option shall be used, it is necessary to enter an exclamation mark in front of the callsign – same in the comment field!

If as third argument after the callsign the channel number is entered, no search for the callsign in the comment fields will be done, the PTC-IIpro starts building up the PACTOR connection directly on the entered channel as described in the last chapter.

Entering **G !DL6MAA 7** in the TRX frequency list mentioned before results in attempts of the system building up a longpath PACTOR link to DL6MAA on 14080 kHz. The entered channel has to be enabled by setting the Gate parameter in the TRX frequency list for gateway operation.

PR→PACTOR gateway connections are indicated in the internal log of the gateway PTC-IIpro with the preamble “G1:” or “G2:” depending on the level of the corresponding PACTOR connection.

### 5.11.3 CHANGEOVER problems

As explained in chapter “PACTOR Duplex” the PR needs in contrast to PACTOR no special changeover characters, that means for example that no <CTRL-Y> is necessary to change the direction. If a PR link and a PACTOR link are connected together, a principle

conflict comes up: It is unreasonable for the PR user to enter *blind* any change of direction control character for the PACTOR link taken part of the connection.

As long as the PACTOR station connected to a PR user via the PR→PACTOR gate executes independently a BREAKIN before text to be send and executes a CHANGEOVER after any text was send, the acting together with the PR station works perfectly. That means that if a PACTOR station is called as a mailbox the PR→PACTOR gate works without problems.

But if a PACTOR station is called which doesn't control automatically the changeover, the PACTOR end user has to take over the whole over control manually! That's in case not possible, if the called PACTOR station works without operator and isn't configured as a mailbox.

Alternative for this handling we suggest to switch the PTC-IIpro gateway in PACTOR Duplex mode (refer to chapter 6.71). But that's not the cure-all, because it might be possible that on the other hand some PACTOR mailbox systems can't work with the PACTOR Duplex mode without problems (refer to chapter 5.12.2, "How to avoid incompatibility?")

### 5.12 PACTOR Duplex and PACTOR data transparency

To simplify the PACTOR operation mode, that means to ensure *compatibility* to many mailbox and terminal programs made for Packet-Radio (PR) while using PACTOR, the possibility of working without the usage of special control key sequences (e.g. <Ctrl> + <Y>) had to be created. Programs written for PR do not know the commands for changeover used in the half-duplex mode on shortwave, because PR reacts in the half-duplex mode on the user interface more or less like full-duplex – a changeover does not exit for PR.

To avoid changeover commands using PACTOR the PTC-IIpro offers a CHANGEOVER-automatism, the so called PACTOR Duplex.

The PACTOR duplex is activated with the new command **PDuplex** (refer to chapter 6.71, page 96). The automatism works with the following relatively simple algorithm:

1. If the PTC-IIpro is the information sending station (☞ISS), that means controls the keys, the PTC-IIpro automatically executes a CHANGEOVER, if his transmission buffer is empty (that means no data to be sent are available).
2. If the PTC-IIpro is the information receiving station (☞IRS), the PTC-IIpro automatically executes a BREAKIN, if the transmission buffer is not empty, that means that data for transmission are available and the IRS state exists for at least 12 seconds.

This automatism causes a variety of conclusions during practical operation that have to be mentioned, especially if the PTC-IIpro with activated PACTOR Duplex has to work together with a *conventional* PACTOR system.

The general usage of the PACTOR Duplex mode is not recommended at the moment, because especially *old* PACTOR mailbox systems have problems with the *unnecessarily*

automatically executed changeover of the PDuplex-PTC. The conventional operation control in the personal *Chat-QSO* should only be switched to PACTOR Duplex mode, if the QSO partner is familiar with what happens and will not be confused by the changeovers of the PACTOR Duplex-PTC appearing accidentally.

The following distinctiveness exists for the PTC-IIpro itself when switched to PACTOR Duplex:

1. The CHANGEOVER bell is generally deactivated.
2. Open files for the PTC internal mailbox will not be closed by a CHANGEOVER any more.
3. Mailbox access of users with PACTOR Duplex are executed correctly (the command interpreter will not be closed as usual by a CHANGEOVER, but generally by a *Carriage Return*).

### 5.12.1 Application for PACTOR Duplex

1. PDuplex can be used excellently to make mailbox programs for PR working with the WA8DED hostmode (**DPBox**, **DieBox**, **GP**, **WinGT**, etc). also usable for PACTOR. The terminal- and mailbox program does not notice on the WA8DED hostmode side any difference between a PACTOR- or PR-link, if PDuplex is activated. No transmission control character has to be send by the PC.

The great advantage of these technique:

The PR program used by a mailbox is compatible to **all** PACTOR users, independently if they use PACTOR Duplex or not. ( It also doesn't matter if a user accesses to the mailbox with PACTOR-I or PACTOR-II).

2. In combination with binary data transparency binary files can now be transmitted directly - e.g. in the Autobin mode via PACTOR – without the detour using 7PLUS or other coding mechanisms. If a file shall be transmitted to a friend using the PTC-IIpro too, both PTC-IIpro are switched to PACTOR Duplex. Using a WA8DED hostmode program all features available for PR can be used on the PACTOR channel (usually channel 4) as well– certainly also the AUTOBIN transfer!
3. Very convient operation with partners using PACTOR Duplex too. In this case the QSO can be made in the same way as in PR – regardless of the actual *transmission state* of the connected PTCs. CHANGEOVER or BREAKIN aren't necessary anymore.

We want to point out that the selection of the QSO style is a matter of taste. The usual operation with manual control of the transmission direction is useful furthermore.

### 5.12.2 How to avoid incompatibility?

PACTOR Duplex allows to experiment a lot, especially using PC software intended for Packet-Radio. Unfortunately side effects arise from using the duplex simulation together with *old* PACTOR systems.

In general the PACTOR Duplex should be switched off before using a PACTOR mailbox - if it is not definitely clarified that the mailbox is able to operate with PACTOR Duplex users.

Also the internal mailbox of the PTC-IIpro reacts incorrect (if the PTC-IIpro isn't switched to PACTOR Duplex), if a CHANGEOVER is executed while entering commands – e.g. when the user operates PACTOR Duplex but enters the command very slowly.

**It would be desirable if all of the mailbox programs for PACTOR could be modified in the way that they could also operate with PACTOR Duplex users without problems.**

### 5.12.3 PACTOR data transparency

The PACTOR Duplex mechanism and the data transparency structure of the WA8DED hostmode make it useful for other applications to fulfil the demand (already mentioned from many users) for data transparency for PACTOR. As already mentioned the transparency in combination with PR programs allows the usage of binary transfer protocols via PACTOR.

Using the WA8DED hostmode the PTC-IIpro sends and receives data in PACTOR absolutely binary data transparent.

Data transparency is only achieved if both sides use the PTC-IIpro with the firmware version 2.4 and higher.

The data transparency certainly includes all characters being attached to special functions in the terminal mode. The consequence is:

Using the hostmode the CHANGEOVER character or the BREAKIN character does **not** cause any change of direction at the PACTOR connection anymore. (Keyboard macros, e.g. in **GP**, which generate these special characters are ineffective!). In the hostmode for changeovers the commands **%O** or **%I** have to be used.

### 5.13 Audio Functions

For special processing and filtering of Audio signals (Audio from the Transceiver) the PTC-IIpro presents its own submenu - the so called Audio-Denoiser menu, **aud:-**menu. The PTC-IIpro is thus also suitable for SSB operation (automatic notch filter) and for CW listening (Automatic peak-filter, CW-filter) and has very useful options. The Audio is presented to the PTC as usual via PIN 4 of the 8 PIN HF radio connector, so that no changes compared with normal RTTY/PACTOR operation are required. The processed or filtered signal is presented at PIN 1 of the HF radio connector, and at PIN 11 of the 13 pin DIN-connector (TRX-REMOTE-CONTROL).

The very high computing capacity of the PTC-IIpro is shown to be very advantageous for the Audio processing algorithm. In comparison to the usual simpler and cheaper Audio Denoiser units, several times as much computing power can be used to optimize the result.

All functions of the **aud:-**menu that process the AF input signal use a 4-stage signal level matching (22 dB adapting range) for the 16-Bit A/D converter in order to keep the quantization effect low and to provide a large effective dynamic range. The PTC-IIpro therefore adjusts itself in stages automatically to the average signal level delivered from the transceiver. A complete description of the **Audio** commands set is given in section Audio (refer to chapter 7, page 119)

### 5.14 The hostmode

The PTC-IIpro supports the **WA8DED** hostmode and an **SCS** specific extension, the CRC hostmode. For detailed information about the hostmode and the hostmode commands refer to chapter 5.14, page 58. Pay attention to the explanations concerning the **TNC** command (refer to chapter 6.96, page 109).

Here you find some important details for the hostmode and PACTOR cooperation.

To make PACTOR accessible from the hostmode, one of the hostmode channels can be reserved for PACTOR operation. On this reserved channel a connect or disconnect command of the hostmode program is effective on the short wave port of the PTC-IIpro and establishes a PACTOR connection or terminates it. If the PACTOR listen mode is activated, incoming text will also be displayed in this channel and not in the monitor-screen of the hostmode program.

With the **PTChn** command the hostmode channel for PACTOR can be set. Default setting is channel 4. If more than one channel is enabled in the hostmode program, it is usual to take the last channel.

If your hostmode program has 8 channels enabled, the command

```
cmd: PTChn 8 <Return>
```

reserves channel 8 for PACTOR.

As the example shows it is only possible in the terminal mode, e.g. in **PlusTerm**, to enter the **PTChn** command.

As mentioned in the chapters about PACTOR Duplex and the PR→PACTOR gateway the hostmode programs naturally have problems with the usual special characters for the changeover in PACTOR (**CHANGEOVER** and **BREAKIN**). Because of this there are special hostmode command which allow the changeover for PACTOR in the hostmode: **%O** causes a **CHANGEOVER** and **%I** causes a **BREAKIN**.

Another comfortable way to initiate a **CHANGEOVER** in the hostmode is to use the command **HCr** (refer to chapter 6.44, page 83). If **HCr** is 1 the PTC-IIpro executes a **CHANGEOVER** for each line feed at a blank line. That's convenient for direct QSOs.

The PACTOR listen mode can be switched on and off with the hostmode command **%L**.

The **JHOST** command is not allowed in the initialization file of the hostmode program! Only the commands mentioned for hostmode (refer to chapter 10) should be used in the initialization and de-initialization files!

## 5 PTC-Firmware

---

If you want to use the PTC-IIpro after power-on directly with a hostmode program, you should set the baudrate with the **SERBaud** (refer to chapter [6.87](#), page [101](#)) command to a fixed value.



## Chapter 6

### 6 Commands

#### 6.1 ACheck (AMTOR Check)

**Default setting: 30**

Parameter: X 0... 100, SNR for AMTOR Packets.

This command allows a much sharper error checking than is possible with previous AMTOR systems. By using the analogue information from the A/D converter, it is possible to estimate the Signal/Noise ratio of the AMTOR blocks or the AMTOR CS signals. (noise in this sense meaning all unwanted signals). As soon as the SNR remains under pre-set, the PTC assesses this packet as containing. This system has the advantage that the amount of undetected errors with signals that contain heavy interference or noise is drastically reduced.

The value range of the **ACheck** command extends between 0 and 100. The value 0 means the additional check is switched off. The value 100 gives the maximum restricted reception. The standard value (30) allows a link, even with very weak signals, with, however, markedly reduced printing errors. Higher values (40-60) are recommended for APLINK, where data is sent over multiple AMTOR links, until the target box is reached, and thus a minimum error rate is to be aimed at. Higher values can however cause a problem when the resync rate climbs considerably. This leads to higher values of transmitted errors, as every AMTOR resync also contains a built-in random component (violation of the ARQ principle).

#### 6.2 ADdlf

**Default setting: 1**

Parameter: 0 Auto LF inhibited.  
1 Auto LF in Baudot RTTY and AMTOR.  
2 Auto LF in Baudot RTTY, AMTOR and PACTOR.

Inserts an automatic <LF > on the transmission side. Some Baudot, RTTY, and AMTOR stations require this to prevent the receiver overwriting lines, which occurs when only a <CR> is transmitted by the PTC. (In PACTOR <CR> normally also contains the *NEWLINE* function).

#### 6.3 Amtor

This command activates the **AMTOR** command prompt. Some commands are automatically adjusted for the new mode. For example, Connect starts an AMTOR ARQ call. The AMTOR SELCALL can be adjusted with the **MYcall** command. The **TR** command becomes valid, etc.

## 6 Commands

---

To differentiate easier, the following system message is given:

```
AMTOR/PTC-II V.3.1 (C) SCS-GmbH 94-01
=====
```

```
**-A-** (DFCJ):>
```

The system gives the following command prompt:

```
**--MODE--** (SELCALL):>
```

MODE is the actual operational mode: **A** for AMTOR, **M** for AMTOR monitor mode, **R** for RTTY, **C** for the CW terminal and **P** for PSK31. *SELCALL* is the present SELCALL of the PTC, e.g. **\*\*M\*\* (DMAA):>**.

It is naturally still possible to receive PACTOR connects, to read PACTOR QSO's, AMTOR FEC and NAVTEX transmissions.

With the **SCS**-PTC-IIpro it is possible to use upper and lower case letters in AMTOR! The PTC uses the PLX-APLINK convention to transfer data. It is thus completely APLINK compatible, and can read messages from, and send messages to the APLINK system using both capitals and lower case.

During the reception of AMTOR transmissions (FEC or ARQ), it is possible that a figure shift, or letter shift character, is lost due to QRM etc. In these cases, using <Ctrl> + <B> (<Ctrl-B>) switches to letters, and normally resolves the otherwise unreadable text.

In an AMTOR QSO, instead of using the usual +? change over sequence, it is possible to use the normal PACTOR CHANGEOVER character. The PTC changes the PACTOR CHANGEOVER character automatically into the +? sequence.

A break in is made using the normal BREAK IN character (**Bkchr**).

### 6.4 APower

**Default setting: 0**

Parameter: X 0... 200, minimal PSK amplitude.

This command allows the automatic transmitter power adjustment of the PTC-IIpro to be switched on and off. If the channel conditions fluctuate rapidly, it is recommended to switch off the Auto Power Option.

APower operates only during a PACTOR-II link.

If **APower** is set 0, no automatic power reduction happens. The audio output amplitude is always equal to the value being set with the command **PSKAmp1**.

If the argument is greater than zero, the auto power will be activated, but the lowest automatically established value will never be below the value defined by the argument of the **APower** command. The **AP** value is equivalent to the *minimal PSK amplitude*. (But it

is furthermore valid, that the PTC-IIpro reduces the power only to 1/64 of the maximum amplitude given by **PSKAmp1**, although the **AP** value would allow further reduction.)

If **AP** is set to 200, the PTC-IIpro will never set the PSK output level below 200 mV. That means that with a **PSKA** value of 140 (setting of the maximum PSK amplitude value, refer to the **PSKAmp1** command, chapter 6.74, page 97) and an **AP** of 200 the power never will be reduced.

If the **PSKA** value is 140 and the **AP** is 70, e.g. the amplitude of the **PSKA** output signal of the PTC-IIpro will at a maximum be reduced by the factor 2 (maximum power reduction by the factor 4).

The setting of the minimum amplitude allows a limitation of the auto power adjustment range. This is sometimes obvious and necessary: Some transceiver only operate proper in a limited power range. This can also increase the average throughput in rapidly fluctuating channels.

In most of all cases the auto power can be switched on with **APower 1**.

### 6.5 AQrg

**Default setting: 1**

Parameter: 0 Automatic carrier frequency compensation switched off.  
1 Automatic carrier frequency compensation for PTC-IIpro switched on.

The PTC-IIpro uses two totally separate compensation methods for frequency error during DPSK operation. The phase error on receive caused by frequency offset is always relatively quickly compensated, switching off this function, which is essential for PSK operation, is not possible. **AQrg 1** activates the second, additional compensation method: The PTC-IIpro pulls the two carrier frequencies of the modems (DSP) slowly towards the set value. This, in contrast to the pure error phase compensation, also influences the focussing indicator (The QRG-Display LED, which slides slowly back to the center position). To prevent completely drifting away from the chosen frequency, the PTC-IIpro uses Master/Slave tracking. This means that the Slave station (Called by the master station) only adjusts its receive frequency, but the Master station (initiating the contact) adjusts synchronously both the RX and TX frequencies (relative to the measured offset of the RX frequency to the set value). Depending on the cycle length and actual signal ratio, as well as on the size of the QRG error variegates the frequency adjustment speed. On average it tends to be around 15 Hz per minute.

### 6.6 ARX

**Default setting: 1**

Parameter: 0 AMTOR phasing disabled.  
1 AMTOR phasing enabled.

With **ARX 0** it is not possible to obtain an AMTOR connect in the standby mode. Also the reception of AMTOR FEC and NAVTEX is disabled.

## 6 Commands

With **ARX** 1, the **SCS**-PTC reacts on an AMTOR connect attempt in the standby mode. Reception of AMTOR FEC and NAVTEX is enabled, provided that the **BC** parameter is set to 1.

The next table explains the interrelationship between **ARX** and **BC**:

<b>ARX</b>	<b>BC</b>	<b>Function</b>
0	X	AMTOR Connects, AMTOR-FEC + NAVTEX reception disabled.
1	0	AMTOR Connects enabled, AMTOR-FEC + NAVTX reception disabled.
1	1	AMTOR Connects, AMTOR-FEC + NAVTEX reception enabled.

Table 6.1: AMTOR and NAVTEX reception

### 6.7 Audio

The audio-denoiser-menu (**aud**:-menu) is available from the main menu of the PTC-IIpro, and is activated with the **Audio** command. The command prompt takes the form **aud**:

The following commands are available in the audio menu:

**Bandwith, Center, CWfilter, DD, Delay, Help, Invert, Level, Notch, Peak, Quit, Through, TOne.**

The *usual* commands of the PTC-IIpro are no longer available for use. You can leave the **aud**:-menu with the **Quit** or **DD** command.

For a detailed description of the audio commands refer to chapter 7, page 119.

### 6.8 BAKup

This command is to be used to back-up the entire PTC mailbox. After entering the **BAK** command, the PTC requests a disk file to be opened, and waits for the input of a <CR>, which starts the actual back-up procedure. After the back-up is finished, the PTC gives a BELL character, to signify that the disk file may be closed.

For Specialists: The Back-up file-format:

```
<CR> ; <CR>=carriage return;
###PTCBAK<BN><CR> ; <BN>=number of 32k-RAM blocks;
<SN><CR> ; blocks (decimal)
; number of BBS blocks

>0000<CR> ; incrementing block number
<S><CR> ; S starts every 256 Byte sector
0000<CR> ; if the first word = 0, this sector is
empty
>0001<CR> ; block number
S<CR> ; S starts every 256 Byte sector
0000<CR> ; empty sector
>0002<CR> ; block number
S<CR> ; S starts every 256 Byte sector
1F1BABC85D56DABC8912D..<CR> ; Occupied sector: 8 lines with 64 nibbles
; follow. After every line a <CR>
```

## 6 Commands

---

.....

```
>xxxx<CR>           ; incrementing block number
S<CR>
FFFF<CR>           ; Last sector starts with FFFF and is
empty
AB3C<CR>           ; 16 bit checksum on all nibbles
```

Before each block the relevant block number is given. (Incrementing, starting with 0.) The sign > is placed at the beginning of the block number.

The block number count enables external software for example, to perhaps recognize any *block loss* that may occur during data transfer, and in such an event, to undertake damage limitation measures. Such measures may, for example, replace the missing block by an empty block.

<CR> or <LF> can generally be completely ignored, so that there should occur no problem due to incompatible terminal programs. The read algorithm by the PTC **RELOAd** synchronizes only with the help of the S start character.

### 6.9 BAUdot

#### Default setting: 45

Parameter: X 20 to 300 Baud.

Switches to RTTY with the given baud rate. E.g. **BAU** 100 switches to RTTY with 100 baud. The baud rate is continuously variable between 20 and 300 baud.

The baud rate can be exactly set, without quantization problems, because an interpolation algorithm is used. The computer also automatically calculates the best low pass filter for the baseband filtering according to the baud rate. This gives excellent receiving characteristics, that hardly vary from the theoretical ideal value.

After **BAU**, the PTC answers with:

```
>>> BAUDOT--RTTY RECEPTION ACTIVE -- SPEED: 45 BD <<<
```

and is ready to receive RTTY transmissions.

Changing to transmit is done with the **CHANGEOVER** character (set with the **CHOchr** command, refer to chapter 6.19, page 69). Changing to receive again is done with the **QRT** character (set with the **QRTChr** command, refer to chapter 6.79, page 99).

Directly after activating RTTY with **BAU**, the PTC is in Converse mode i.e. all entered characters are send to the transmission buffer. This has the advantage that text can be typed ahead. During the other station's transmission, it is possible to type in the station description or other message, for example a welcome. After switching to the transmit mode the text will be sent immediately. To enter a command to the PTC, an ESC character (defined with the **ESCchr**, refer to chapter 6.39, page 80) must be given first. In RTTY mode, the AMTOR-prompt is in the form of: **\*\*--R--\*\* (DFCJ):>**

After approximately 4 minutes of idle transmissions, an automatic QRT is carried out!

## 6.10 BC

### Default setting: 1

Parameter: 0 FEC reception disabled.  
1 FEC reception enabled.

AMTOR FEC and NAVTEX reception is disabled or enabled. If **BC** =1 the PTC will receive AMTOR FEC transmissions in the STBY mode.

With the **ARX** command the reception of AMTOR-FEC and NAVTEX can be disabled independent from the setting of **BC** refer to [Table 6.1](#) on page 64)

## 6.11 BELL Remote

### Default setting: 1

Parameter: 0 SYSOP calling disabled.  
1 SYSOP calling enabled.

Use of this command causes an intermittent beep (approx. 10 secs) at the remote station. It serves as a SYSOP call. The SYSOP can interrupt the beep by pressing any key on the keyboard (e.g. <Return> or <Esc> The SYSOP can either enable the **BELL** command (1), or disable it (0) on his system.

**BELL** also has an effect on the Sysop bell of the Packet-Radio side!

## 6.12 BKchr

### Default setting: 25 (Ctrl-Y)

Parameter: X 1... 127, ASCII code of the character (decimal).

Defines the BREAKIN character used for PACTOR and AMTOR.

The BREAKIN character is a special command for a forced direction change from RX to TX (~~Ⓡ~~BREAKIN). Because this command is used very often, the PTC accepts the BREAKIN character only directly in the converse mode, that means that the command can not be used after the **cmd:**-prompt.

The BREAKIN character may be changed to any other convenient character with this command at any time.

<Ctrl-B> as BREAKIN character is defined with the command: **BK 2**.

The following characters are not permitted: 8 (Backspace), 13 (CR), 32 (Space), 30 (IDLE), 17 (XON), 19 (XOFF), and other already specified special characters.

### 6.13 BMsg

#### Default setting: 1

Parameter: 0 RTTY/PSK31-RX/TX switching messages off.  
1 RTTY/PSK31-RX/TX switching messages on.

Switches RTTY/PSK31-RX/TX switching messages on or off. To switch off the relatively long switching messages is helpful for RTTY- and PSK31 contests to prevent a rapid scrolling away of useful text.

### 6.14 BOOT

Use **BOOT** to load the PACTOR firmware via the serial interface into the RAM. This is mainly used for testing during software development. **BOOT** only works in connection with a special load program and can not be used with a normal terminal program.

### 6.15 Box

#### Default setting: 0

Parameter: 0 Mailbox control with // sequence.  
1 Mailbox in direct mode.  
2 As in 0 but only personal messages.  
3 As in 1 but only personal messages.

The command **Box 1** brings the PTC mailbox into the direct access mode. Remote commands can be given without using the //-sequence, and the remote command is ended with a <Return>. The PTC indicates that it is in the direct mode by giving out **next?** as a prompt to the remote station, showing it is ready for the next command.

The **next?** command prompt is changed to an identification output at every fourth occurrence. The identification prompt looks like: **hiscall de mycall**> and is to comply with the regulations of virtually all amateur licenses concerning identification of stations. This increases the Overhead of the box only very slightly, as the callsigns are given in small letters, and thus lend themselves to efficient Huffman coding.

If the remote-user wants enter a command with using the //, the two slashes are ignored and the command will be executed.

Direct box access has priority compared with the **REMOte** parameter of the PTC. (The direct access is always possible, even when **REMOte** = 0). Indirect mailbox access means that commands can only be given using the // sequence, (e.g. **//help**, and ending with a CHANGEOVER). The indirect box access can be disabled with the **REMOte** command.

Direct box access is automatically disabled when the PTC works as master. (if the PTC has initiated QSO). If however, the **Box** command is used to change the box access parameters during the connect, this new setting will be valid immediately, independent of whether the PTC is the Master or Slave.

At **Box 2** and **Box 3** settings only messages to the own callsign (MYCALL) will be accepted.

### 6.16 **BRightn**

**Default setting: 6**

Parameter: X 1... 7, brightness value.

This serves to set the brightness of the LED display between 6% and 100%. The parameter 1 is equivalent to 6% of the maximum brightness. Parameter 7 represents 100%. The LED dot-matrix display requires considerable current at higher brightness levels, and increases the power requirements of the PTC-IIpro considerably it is recommended therefore, that the brightness during STBY periods (particularly for mailboxes that operate round the clock) should be reduced to 6%.

### 6.17 **CHeck** Remote

(from the remote side entering **C** is enough, see also **Connect**, chapter 6.22, page 70)

**Default setting: 10**

Parameter: X 1... 100, number of mails to be listed.  
P List private mail only.

**CHeck** without argument lists the newest 10 public mails of the mailbox. With a numerical argument between 1 and 100 it is possible to define the quantity of mails to be listed. The output format is described in chapter 6.36, page 79 (**DIR**).

**CHeck** followed by the argument P lists the private mails. A numerical argument may follow to define the quantity of mails to be listed. Also refer to chapter 6.22.5 on page 72.

**CHeck P 30** lists the newest 30 private mails

### 6.18 **CHOBell**

**Default setting: 1**

Parameter: 0 CHANGEOVER bell off.  
1 CHANGEOVER bell on.

As a default, a CHANGEOVER (change of data transmission direction) is indicated by a beep of the internal beeper. In addition, the PTC sends for each CHANGEOVER a BEL character (ASCII 7) to the terminal and let it beep. **CHOB 0** disables both the sending of the BEL character to the terminal and the beep of the internal buzzer.

## 6.19 CHOchr

**Default setting: 25 (Ctrl-Y)**

Parameter: X 1... 127, decimal ASCII code of a character.

Defines the CHANGEOVER character.

**CHOchr** defines the CHANGEOVER character which is a special command for the change from TX to RX. Because this command is used very often, the PTC accepts this character only in the converse mode, and not after the **cmd:-**prompt. The CHANGEOVER character is not part of the transmitted data and will not be transmitted.

A CHANGEOVER initiated by the TX operator is not executed until all text in the transmit buffer is transmitted.

In AMTOR, the CHANGEOVER character has a further function. In an AMTOR QSO, (AMTOR-ARQ / Mode A), the CHANGEOVER character can be used instead of the +? sequence. Whilst in AMTOR standby, the CHANGEOVER character can be used to initiate an FEC (Mode B) transmission. Whilst in AMTOR monitor mode (Mode L) it causes a new synchronization.

In RTTY (command **BAUdot**) the CHANGEOVER character switches to transmit.

The CHANGEOVER character can be changed at any time using the **CHOchr** command.

Using <Ctrl-Z> (entering <Ctrl> <Z>) as a CHANGEOVER characters is defined with the command **CHO 26**.

Illegal values are 13 (CR), 32 (Space), 30 (IDLE), 17 (XON), 19 (XOFF), and other previously defined special characters.

## 6.20 CLr Remote

Deletes the transmit buffer. Everything that is contained in the transmit buffer, which has not yet been transmitted, is deleted.

## 6.21 CMsg

**Default setting: 1**

Parameter: 0 Connect text off.  
1 Connect text on.

This command turns the connect text on or off. There is only one common connect text for AMTOR and PACTOR. Therefore **CMsg 1** enables the connect text in PACTOR as well as in AMTOR.

## 6.22 Connect

### Default setting: previous address

Parameter: ADDR Callsign of the station to be connected with.  
!ADDR Starts a long path call.  
%ADDR Starts a call using the “robust-connect” feature

Used to build up a connection. The **Connect** command may be followed by the argument being the callsign of a distant station. The callsign length can vary between 2 and 8 characters. Too short arguments are ignored. If the callsign is too long it will be truncated at the end. If no argument is given the old or the default callsign will be called. **Connect** can be repeated with different callsigns until a connection is established. In the connected condition, the **Connect** command can be used to display the callsign of the distant station.

If no response is received after the number of retries set by the **MAXErr** command, the PTC terminates the connect attempt automatically with displaying an error message. A call can be stopped manually using the **Disconnect** command.

### 6.22.1 Longpath-connect

With an exclamation mark (!) or a semicolon (;) is set directly before the callsign (example: **C !DL0WAA**) it is possible to call using sync packets with long path options. The cycle time increases to 1.4 seconds and the control delay becomes long enough for ARQ contacts to over 40,000 km (TRX-Delay 25 ms). PTC1 systems (Z80-PTC) with a firmware version number <1.3 are not able to detect syncpackets with long path options and don't react on long path calls. During connections using the long path option the throughput decreases to approximately 90% of the usual throughput.

If the long path option was used for last PACTOR connection or the last MASTER connect attempts (exclamation mark before the callsign), all of the following **Connect** commands **without an argument** will start a call using the long path option.

### 6.22.2 Robust-connect

The PACTOR-II robust connect procedure *Robust Connect* allows reliable link establishment even under extremely poor and difficult signal conditions. Up to firmware version 3.1, the *Robust Connect* has only been available as a part of the Professional PTC-IIpro firmware. With version 3.1 *Robust Connect* will also be available as a part of the "normal" firmware, but restricted to outgoing calls/connects, i.e. **only** systems equipped with the *Professional Firmware* (also known as *Marine Firmware*) are able to accept *Robust Connect* frames:

Two PTC-II's both running the "normal" Firmware cannot mutually connect using the <i>Robust Connect</i> since only the <i>Professional Firmware</i> is capable of receiving <b>and</b> accepting <i>Robust Connect</i> frames. As opposed to the <i>Professional Firmware</i> , the "normal" firmware <b>will not</b> recognize incoming <i>Robust Connect</i> frames. On the other
---

## 6 Commands

hand it **can** generate outgoing *Robust Connect* frames and thus initiate a link using the *Robust Connect* procedure if the remote system runs the *Professional Firmware*.

A *Robust Connect* can be started by prefixing the call sign (argument of a connect command) of the distant system with a "%" sign, e.g.:

**cmd: c %DL1ZAM <Enter>**

This is also valid for WA8DED hostmode. In terminal mode the PTC-II(e) will respond as following:

```
*** NOW CALLING DL1ZAM (ROBUST CONNECT)
```

In case of a connect command without argument, the PTC-IIpro automatically inserts the call sign used by the remote system during the latest connection. If the link was initiated by the PTC-IIpro itself and the *Robust Connect* procedure was utilized, the PTC-IIpro will not only insert the call sign but also automatically add the %-sign and thus re-invoke the *Robust Connect* procedure.

The *Robust Connect* uses "normal" PACTOR timing. Longpath option and *Robust Connect* **cannot** be combined! The call sign of the remote station may only be prefixed by "%" OR "!".

### 6.22.3 AMTOR

With an active AMTOR prompt the Connect command starts a connect attempt, trying to establish an ARQ link (mode-A). Certainly the AMTOR selcall of the distant station has to be entered instead of the callsign. For example: **C DFCJ**. The station with the selcall DFCJ will be called in AMTOR ARQ. If the call is repeated, then the selcall can be omitted.

### 6.22.4 Direct frequency entry

With starting a PACTOR connect, optional a frequency value (separated by a comma) can be entered after the target callsign. This is valid for the connect command in the terminal mode (e.g. **PlusTerm**) as well as in the host mode.

**cmd: c dl1zam,3582.60 <Return>**

In this example first of all the PTC will send the frequency information to the TRX, the TRX sets the VFO to 3582.600 kHz and starts calling (on this frequency). To use this function the transceiver must be capable to be remote-controlled using the TRX remote control option of the PTC-IIpro, utilizing the socket for remote control of the PTC-IIpro. The remote control parameter have to be set correctly using the **TYPe** command of the **trx:-menu**.

This notation is very handy for simple callsign lists with the corresponding frequency information. The list entries directly can be entered as Connect arguments. Also the manual input of the frequencies should be convient enough.

### 6.22.5 FlexNet-Style PACTOR→PACKET-Gateway

In PACTOR-connected condition and with **BOX** set to 1 (**next?**-prompt) the PTC-IIpro accepts the **Connect** command from the distant station with a callsign as argument. The command interpreter automatically recognizes if the argument is a callsign or not. If no argument or a character as an argument is given, the PTC executes the **Check** command.

If a callsign is detected, the system attempts to build up a gateway connection on Packet-Radio using the  Flexnet style. That means that the PTC automatically inserts the Digipeater call (set with the **Gate** command by the sysop) at the first place of the via path. The remote-user enters in PACTOR:

```
next?: c DB0GV <Return>
```

The PTC attempts the connection to DB0GV via DB0KT on the PR side, provided that the sysop has defined the Digipeater call DB0KT to be the first target in the queue of digipeaters.

The **Gate** command at the sysop side allows the entry of a target call or a target path for each PR port separately. As usual for Packet multiport commands the sysop can precede the argument of the **Gate** command optional with 1: or 2: (If no port information is given, the PTC assumes port 1).

```
Using cmd: Gate 2:DB0ZDF <Return>
```

sets the first Target-Digi for gateway connects for port 2 to DB0ZBF. These setting is then completely independent from the settings for port 1. The target Digi-call for port 2 does not override the Target-Digi for port 1. The PTC stores the Target-Digi information for both ports separately.

Note: The Target-Digi path may consist of more than one callsigns, e.g.:

```
cmd: Gate 2:DB0ZDF DB0KT <Return>
```

If the user input on PACTOR side is:

```
next?: c 2:DL6MAA <Return>
```

The PTC executes at the Packet port 2 the following command:

```
C 2:DL6MAA via DB0ZDF DB0KT
```

The gateway messages are adapted to the FlexNet messages for the advantage that various WA8DED host mode terminal programs can be used in PACTOR for very comfortable PR (Gateway) access and always display the *correct* actual call of the already connected station at the *end of the link*.

The message for gateway connect is: \*\*\* connected to

The message for gateway disconnect is: \*\*\* reconnected to

Alternatively the **Gate** command could be used from the remote side (refer to chapter 6.43, page 82).

## 6.23 CONType

**Default setting: 3**

Parameter: 0 Accepts no connects  
1 Accepts only *normal* connects  
2 Accepts only *robust* connects  
3 Accepts all connects

**CONType** defines which connect types the PTC-IIpro accepts while in standby mode and with this leads to a connection to be established.

## 6.24 CSDelay Remote

**Default setting: 5**

Parameter: X 1... 16, delay in X • 5 msec.

Selection of time delay between the end of the RX packet, and start of the first CS data bit. The time equals the value X multiplied by 5 milliseconds. The parameter influences the response time (controls) of the RX at RX start. With a large value for **CSDelay**, even transceivers that have slow transmit-receive switching can be used for PACTOR. The maximum distance that can be covered is reduced due to the time delay caused by the final speed of radio waves. DX is only possible with fast transmit-receive switching.

## 6.25 CText

**Default setting: PTC-IIpro DSP/QUICC System Maildrop QRV...**

Parameter: String of 249 characters, maximum.

There is only one connect text for PACTOR and AMTOR. The Connect text is transmitted when **CMsg** is set to 1 and the PTC receives a connect. In this case the PTC immediately switches into TX mode.

As the CTEXT input happens using the command interpreter, one convention for the <CR>- character has to be followed: A <CR> is represented in the CTEXT string by a '#'.

```
This is DL6MAA in Mindelheim  
The terminal is at the moment not active!
```

```
73 de Peter.
```

The following text has to be entered:

**cmd: CTE** This is DL6MAA in Mindelheim# terminal is at the moment not active!##73 de Peter <Return>

The command interpreter buffer is 256 characters long. Command with argument should not contain more than this number of characters, otherwise the Connect text will be truncated.

### 6.26 CTrlchr

**Default setting: 22 (Ctrl V)**

Parameter: X 1... 127, decimal ASCII code of a character.

Defines the Ctrl character.

If the Ctrl character is immediately followed by a-z (or A-Z), the PTC will transmit a control code (ASCII 1-26) via HF channel. With this simple convention, control characters that are used by your own terminal can also be sent to the other station.

If Ctrl-W should be transmitted to the other station, the following keys have to be entered: <Ctrl> + <V> or <Ctrl-V><W>

It is recommended to put all definable control characters in the control block.

XON and XOFF (Ctrl-Q / Ctrl-S) can not be transmitted!

### 6.27 CWid

**Default setting: 1 0**

Parameter 1: 0 CW identification disabled.  
1 CW identification enabled only for PACTOR ARQ.  
2 CW identification enabled for PACTOR ARQ and Unproto.  
3 CW identification enabled for PACTOR ARQ, Unproto, AMTOR ARQ.  
4 CW identification enabled only for PACTOR ARQ (refer to text).  
5 CW identification enabled for PACTOR ARQ, Unproto, AMTOR ARQ.

Parameter 2: 0 *Normal* CW identification using with keying the PTT.  
1 CW identification before each PACTOR- or AMTOR-ARQ connect.  
2 Audio-Only CW identification (refer to text).  
3 Combination of 1 and 2.

Automatic CW identification is given after a transmission of approximately 7 minutes and after QRT. The CW identification is keyed with the PTT line. The FSK output remains at the Mark frequency during the CW Transmission. The AFSK signal amplitude is also keyed. The frequency for AFSK is defined by the **Center** command in the Audio menu (refer to chapter 7, page 119). The speed is set with the **CWspeed** command.

With **cwid** 1-3, the CW identification is only given at QRT if it is self initiated. With **cwid** 4 and 5, it does not matter which station initiated the QRT procedure.

The CW identification requires a quick keying of the transmitter and usually uses the PTT line for this purpose. This method produces a more or less noisy *clicking* of the transmitters relays, especially the older ones. A *bad* experience could be that the CW character could be mutilated to illegibility if relatively high RX/TX switching times are in use.

In this case the second parameter could be switched to Audio-Only CW identification. That means that the PTT will be active during the whole CW identification process and

only the audio signal is switched on/off in the rhythm of the CW signal. The CW identifications uses the Mark tone.

Switch CW identification to Audio-Only:

**cmd: cw 1 2** <Return>

For CW identification, one's own callsign (**MYCALL**) is always used.

### 6.28 CWMoni

**Default setting: 1**

Parameter: 0 CW monitor tone disabled.  
1 CW monitor tone enabled (TX).  
2 CW monitor tone enabled (RX /TX).

Defines the operation of the CW monitor:

With **CWMoni 1**, the PTC produces a side tone using the internal buzzer representing the transmitted CW characters entered at the CW terminal.

**CWMoni 2** also produces a tone from the received demodulated CW characters from the CW terminal.

### 6.29 CWSpeed

**Default setting: 160**

Parameter: X 40... 1200, CW speed in LpM.

The **CWSpeed** command enables the CW speed to be set continuously between 40 and 1200 LpM (Letters per minute).

The CW speed applies to the CW ID as well as to the CW terminal.

### 6.30 CWTerm

**Default setting: no**

Parameter: X 40... 400, Start receiving speed in LpM.

The **CWTerm** command activates the CW terminal of the PTC-IIpro. The actual speed depends on the **CWSpeed** parameter. The keying takes place using the PTT line, as with the **CWID**. The FSK line remains constant on the Mark frequency. The AFSK signal amplitude is also keyed. The frequency for AFSK is defined by the **Center** command in the **Audio** menu (refer to chapter 7.2, page 119).

After activating the CW terminal, characters from the keyboard, that can be translated into Morse, are transmitted as Morse code by the PTC.

## 6 Commands

---

If an argument is entered, the decoder starts in the fix-speed-mode, that means that automatic speed adaption is disabled. This is recommended for recording *commercial* CW transmissions (weather report etc)., whose speeds are known.

When nothing is input at the keyboard, (and the transmit buffer is empty), then the CW terminal is in receive mode. The actual receiving speed can be determined with the **SHOW** command.

When a command shall be sent to the PTC, (e.g. **DD**) then the ESC character (refer to chapter 6.39, page 80) has to be sent first, as the PTC operates in *Converse* mode when the CW terminal is active.

When the CW terminal is in use, the AMTOR prompt is displayed, though the **A** is replaced by a **C**. As mode status (Status Level = 1) is shown RTTY, as the function of the terminal in most respects resembles the RTTY module.

The demodulator uses the talked about technique of the Auto-Correlation filter in the Audio-Menu (refer to chapter 7, page 119). This enables even weak signals to be reliably detected **without** tuning problems. (An ideal filter for a CW signal with a speed of 60 BPM exhibits a 0/0 bandwidth of only 20Hz, which with conventional methods requires extremely exact and stable tuning for good results).

The Auto-Correlation method is also the basis of the AGC used in the CW demodulator, with a dynamic range of approximately 40 dB. The AGC allows a constantly good receive performance, independent of audio input signal level.

A CW signal must be tuned in that way that the tuning indicator on the PTC shows the right most LED lit when a CW signal tone is present. If only noise is present within the PTC receiving channel, only the left LED's of the tuning indicator flicker. With a correctly adjusted CW signal, the traffic LED lights when the CW signal is there, and the idle LED when it is not.

The Audio frequency of the CW terminal is defined by use of the **Center** command of the **aud:**-menu, independently of the actual Mark frequency (refer to chapter 7.2, page 119).

The CW terminal offers the use of a number of so-called hot-keys:

**BREAKIN-Character (Ctrl-Y):** When pressed twice, the BREAKIN character leads to switching between direct transmission of the keyboard input (Immediate transmission mode), and a delayed switch over (Delayed transmission mode).

This delayed switching allows text to be "typed ahead" whilst reading the other QSO partners transmission. The text in the buffer can then be transmitted by pressing the BREAKIN-character (<Ctrl-Y>) once. The transmission is then only blocked again when no characters are transmitted for 6 seconds. This has the advantage that user may continue writing after the buffered text is sent, without having to press any other key. The renewed blocking of the transmitted is shown by the PTC-IIpro with the message '>>>' written to the Delayed Echo-window.

After switching to the CW-Terminal, one is always in the direct transmission mode.

## 6 Commands

---

**Ctrl-U and Ctrl-D:** Increases (Up) or decreases (Down) the decoder speed by 1/16 the actual value. This is mainly for use when the automatic RX speed adjustment is turned off.

**Ctrl-F:** Switches between automatic and manual RX speed adjustment (fixed speed mode). On switching between the two possibilities, the present speed is taken without change, so that in practice, one can leave the automatic adjustment running for a while to set the correct speed, then press <Ctrl-F> to keep this setting. The operation with a fixed speed has definite advantages with weak signals, or signals with heavy fading. The decoder withstands speed errors of 40 percent without problem, so that even with a fixed speed setting, virtually no reading errors are found.

After switching to the CW-Terminal, one is always switched to the automatic speed adjustment mode.

The PTC's automatic CW decoder can operate with speeds between 30 and approximately 300 letters per minute, and scans this range within 10 seconds.

It decodes	all letters from	a-z
	all numbers from	0-9
	special characters	, . : ? / - = SK# EB> AR* KN( VE+ KA!
	German Umlauts	ä, ö, ü or ch

All ambiguous signals are ignored.

Naturally, an automatic decoder can only decode relatively well sent Morse code signals. One hears unfortunately much badly sent Morse on the bands (not only amateur signals!!) where commonly the Mark/Space ratio is incorrect. One must then bear in mind that not all CW QSO's will be correctly decoded.

The CW terminal can be closed with the **D** command, or **DD** may also be used.

### 6.31 CWWeight

**Default setting: 50**

Parameter: X 5... 95, weight of CW characters in %.

This command sets the *weighting* of the CW character, that is dot dash relationship, together with dot space ratio (between character elements). Standard CW shows a ratio between dots and spaces of 1. The dot dash relationship is 3 to 1. With *lighter* CW characters, the ratio between dot and dash length is larger than 3, and the space to dot relationship greater than 1.

With a **CWweight** value of 50 (%), the PTC operates with normal ratios. With values greater than 50, the weight of the characters increase, and with smaller values, they decrease (percentage-wise). A weight of 25 means that the dot length would be only half that of the normal setting, the space length being respectively longer, this leading to a space to dot ratio of 3 to 1. The speed naturally stays the same, as the complete character length is not influenced by **CWweight**.

The value of **CWweight** influences the CW identification as well as the CW terminal.

### 6.32 CYcle

**Default setting: 2**

Parameter: 0 Always switching to short cycles.  
          1 Always switching to long cycles.  
          2 Adapt cycle length adaptive.

**CYcle** defines the cycle length used for a PACTOR-II connect.

Usually this command is used for test purposes (speed comparison, etc). and is described here for the sake of completeness.

### 6.33 DAte Remote

**Default setting: none**

Parameter: DD.MM.YY Desired date.

Arguments are ignored during remote control.

**DAte** is used to set or read the PTC calendar. If **DAte** is entered without a parameter, the PTC-IIpro displays the current date.

All positions have to be entered. Leading zeros must not be omitted. The periods for separation are not necessary. Faulty inputs cause incorrect programming of the clock chip!

From 01.01.1990 up to 31.12.2089, the day of the week is automatically calculated from the date. Thus your PTC-IIpro is well equipped for the future (**Y2K no problem**)!

Required date Sunday 24th March 1999.

**cmd: DA 24.03.99** <Return>

Or in shortform

**cmd: DA 240399** <Return>

### 6.34 DD

This command causes an immediate breaking off of the transmission ('Dirty Disconnect'). An existing link is not correctly terminated. Any text that remains in the transmit buffer is discarded.

**DD** leads, in all cases, back to the respective STBY level..

### 6.35 DElete Remote

Deletes files in the PTC mailbox. Remotely it is only possible to delete self written files or files written to you.

**DEL DL2FAK 1-** Erases all messages addressed to DL2FAK.

## 6 Commands

---

**DEL** DL2FAK 4 Erases message no 4 addressed to DL2FAK.  
**DEL** DL2FAK 4- Erases all messages from no 4 onwards for DL2FAK.  
**DEL** DL2FAK 3-5 Erases messages no 3 to 5 addressed to DL2FAK.  
**DEL** ALL 4-5 Erases own messages no 4 to 5 in directory ALL.

### 6.36 DIR Remote

Note: **DIR** can from the remote side be shortened to **D!**

If given without parameters, **DIR** shows the mailbox entries, divided into two groups, private (callsign as subdirectory) and public (bulletin) mail, and the free memory available in the mailbox.

If **DIR** contains as a parameter the name of a subdirectory, then the contents of this subdirectory will be listed, e.g. **DIR test** shows all files in the subdirectory 'test'(refer also to **L!st** in chapter 6.49, page 84)

**DIR** without parameter appears similar to below.

```
Main Directory:
ALL PTCPLUS    TEST
DL3FCJ
242222 bytes free
PATH: TEST>
```

Various subdirectories, the free memory (dependent on the RAM fitted) and the present subdirectory are displayed. **DIR DL3FCJ** (Identical to **L!st DL3FCJ**) lists the contents of the subdirectory DL3FCJ.

That can appear like this:

Directory of DL3FCJ:

NR	ST	FROM	DATE	TIME	SIZE	TITLE
--	--	----	----	----	----	-----
1	RP	DL1ZAM	02-MAR-94	17:13:45	1144	New Info
2	RA	DK5FH	02-MAR-94	23:30:22	1502	
3	NP	DL2FAK	03-MAR-94	13:25:15	1362	Mistake!
4	NP	DL6MAA	03-MAR-94	23:31:46	927	New Software
5	NP	DL3FCI	04-MAR-94	20:05:10	501	Coffee on Sat

PATH: DL3FCJ>

#### Meaning of the different columns:

NR: The file number.  
ST: Status  
R Message already read  
N Message not read yet  
A Message recorded in AMTOR  
P Message recorded in PACTOR

## 6 Commands

---

X Messages recorded in Packet-Radio.  
FROM: Callsign of the station that entered the message.  
DATE / TIME: Date and time when the message was recorded.  
SIZE: Size of message in byte.  
TITLE: Title of the message if available.

### 6.37 Disconnect

An existing link (including Unproto) is closed down correctly. If any text is still in the transmit buffer, this is first transmitted, then the PTC starts the QRT sequence.

### 6.38 EQualize

**Default setting: 0**

Parameter: 0 No transmit equalizing  
            1 Slight enhancement of the edge tones  
            2 Moderate enhancement of the edge tones

**EQualize** allows slight to moderate adjustment of the frequency response of the PACTOR-III transmit signal.

Some IF filters used in standard SSB transceivers already attenuate the edges of only 2 kHz wide signals due to a poor frequency response. As a countermeasure EQ allows to compensate for this effect. Please do only use the EQ command if you really know the actual transmit frequency response of your transceiver.

### 6.39 ESCchr

**Default setting: 27 (ESCAPE)**

Parameter: X 1... 127, decimal ASCII code of a character.

Defines the ESCAPE character.

When the PTC is in the converse mode (ARQ, FEC, CW terminal or RTTY) an ESCAPE character is required in order to get a command prompt and input a command.

Note: To ensure proper operation of the PTC-IIpro's automatic baudrate detection only odd values for the ESCAPE character should be used (Refer also to chapter 3.2, page 11)!

We recommend not to experiment with this character, since it is critical to the control of the PTC.
---

### 6.40 FAX

In the main menu (**cmd:**) **FAX** leads to the **fax:-**menu. The command prompt takes the form **fax:** (in the fax menu other modes are also available, so basically it is not meant as a FAX-only menu).

The following commands are available in the **fax:-**menu.

Mode commands:

**Amfax, Fmfax, Jvfax, Sstv, Fsk, Comparator, PR300.**

Parameter commands:

**AGain, AResolut, FResolut, SResolut, FSKBaud, Deviation, MBaud, SMode, HSynch, JSynch, TXcomp.**

All other (*normal*) commands of the PTC-IIpro are no longer available for use in the **fax:-**menu! You can leave the **fax:-**menu with the **Quit** or the **DD** command.

For a detailed description of the FAX and SSTV commands refer to chapter 10.

### 6.41 FEc

This command starts an AMTOR FEC transmission (Mode-B). When the AMTOR prompt is active, then this command has the same effect as the CHANGEOVER character.

After approx. 4 minutes of pure idle transmissions, an automatic QRT is carried out.

### 6.42 FSKAmpl

**Default setting: 60**

Parameter: X 30... 3000, AF output voltage (peak to peak) in mV.

This serves to set the Audio output (transmitted signal) of the PTC-IIpro for all non PSK modes. Before this value is changed, the PSK amplitude should have been correctly set (see **PSKAmpl** command, chapter 6.72, page 96).

After the PSK amplitude has been correctly set, the transceiver MIC gain control should **not** be further adjusted to attain the required power output for non PSK modes.

For this adjustment, (i.e. FSK/CW output power) exclusively use the **FSKAmpl** command. The transceiver should be connected either to a dummy load of appropriate power handling capacity, or a well matched antenna. (please pay particular attention that the chosen frequency is really free. Using **U 1** <Return> the Unproto mode 1 is started (100 Bd FSK). Now, using the **FSKAmpl** command, (use the ESCAPE character to enter the command mode before each change) adjust the audio output level of the PTC-IIpro until the required output power is reached (e.g. <ESC> **FSKA** 100 <Return>). It should be noted that the ALC level of the transceiver must not exceed the prescribed level (exactly as with PSK). To prevent possible damage to the average TRX, caused by continuous transmission, we recommend that the FSK output power should never exceed 50% of the maximum PEP power. In the case of the average amateur transceiver of 100 watts, this represents the 50 watt level. The internal impedance of the AF output stage of the PTC-IIpro is 330 Ohms and resistive.

**6.43 Gate Remote**

The **Gate** command allows unlimited access to the Packet network via PACTOR. The gateway is implemented totally within the PTC-IIpro.

The **Gate** command may be used from the terminal (local), or from the remote station.

From the terminal (local command) a default callsign can be set which will be used when a remote user only gives the command **Gate**. The possible local arguments are either NONE or a valid callsign. A length up to 30 character is allowed for the *callsign*, that means that it is possible to enter a complete path with digipeater as a target of the PACTOR→PR gateway. So it is possible to enter 'DL1ZAM-8 DB0KT DB0GV-7' as a target call. Using this, with only the **Gate** command also not directly reachable targets can be connected (The length of maximum 3 complete callsigns is enough for modern autorouters, e.g. FlexNet router).

**Gate** DB0GV-7

The remote user only enters **Gate** and the PTC-IIpro builds the link to the digipeater DB0GV-7.

**Gate** NONE

Additionally to the **Gate** command the remote user has to enter a callsign.

Operated from a remote station:

If the command **Gate** without argument is sent and closed with <Return> then a link is established to the default callsign previously input by the sysop locally.

If the command **Gate** with a target callsign as an argument is entered from remote then the link made with/to the given callsign.

**Gate** DB0GV <Return>

causes a connect to the PR mailbox DB0GV.

Optionally, the port number of the PTC-IIpro can be set before the callsign of the target digi:

**Gate** 1:DB0GV <Return>

General comments to the operation:

After a successful gateway connect is established, the PACTOR link serves only as a *data throughput medium*, i.e. no direct commands to the PTC-IIpro are possible now. If the gateway link with the digi is lost, e.g., through a **Q(uit)** command to the digi, then the *normal next?* prompt is displayed by the PTC-IIpro and the normal internal commands are available again. A new gate access is also possible.

The CHANGEOVER control is completely performed by the PTC-IIpro itself when in Gateway mode. The user should **never** initiate a CHANGEOVER.

An additional feature is using the **Gate** command with the argument 2. If the user enters on the PACTOR side the command **G 2**, the PTC attempts to build a link to the digi defined by the sysop as target digi for port 2.

Alternatively the FlexNet style gateway can be used. For further information refer to chapter 6.22.5, page 72.

### 6.44 HCr

**Default setting: 0**

Parameter: 0 Auto CHO after an empty line off.  
1 Auto CHO after an empty line on.

If **HCr** is 1, then, in hostmode, a CHANGEOVER is carried out after an empty line (double <CR> or <Return>).

### 6.45 Help Remote

**Help** without parameters gives a list of all commands.

The PTC contains a short description of every command, so that the manual does not need to be continually consulted. These descriptive messages can be obtained by using **Help**, followed by the required command.

**Help** bau (or in shortened form **h** bau.)

From remote, **Help** results in only those commands that can be remote controlled being listed.

A thorough description of each command can also be obtained by the remote station, using **Help** <CMD>.

**Help** phase or **Help** bell.

### 6.46 LFigure

**Default setting: 1**

Parameter: 0 no insertion of <LF>.  
1 insertion of <LF> after each <CR>.  
2 multi-<CR>-supression

**LFigure** determines whether a <LF> is automatically appended to each <CR> that is sent to the terminal. For **LFigure** 0 the characters are passed exactly as the PTC receives them. For **LFigure** 1 <LF>'s sent to the PTC are ignored (refer also to command **ADdlf**, chapter 6.2, page 61).

**LFigure** 2 activates in addition the multi-CR suppression with RTTY and AMTOR/FEC reception. (Multiple <CR> in a row without other characters between are suppressed except for the first <CR>. In the EOL (End Of Line) sequence in some US-American controllers, <CR><CR><LF> no longer causes an unwanted empty line. A number of commercial RTTY services (e.g. Meteo services) also still use the historical double-CR at the end of every line. These services can be better copied when LF=2.

## 6.47 LICENSE

**Default setting: none**

Parameter: X License key.

The **LICENSE** command is to enter or to readout (if already entered previously) the License key which enables extended (professional) firmware functions.

The following messages will be returned by the PTC-IIpro, depending on licensing status:

If the license is invalid:

**LICENSE: NOT OK, XY TRIAL CONNECTS REMAINING**

Whereby XY is the number of remaining test connects.

If a valid serialnumber license is installed:

**LICENSE: SERIALNUMBERXYZO ABCDEFGHIJKL**

The following operating modes are subject to be licensed:

- PACTOR-III connections.
- PACTOR connections to be established using the HAYES command interpreter.
- PACTOR connections to be established using the Free-Signal-Protocol.

Only these operating conditions are decreasing the trial counter, which represents the remaining quantity of test connections using the feature respectively. As soon as the trial counter reaches zero, the features are not available any more unless a valid license code is entered. Other features than mentioned above are not not affected and with this still available after the trial period is exceeded.

## 6.48 LIN

**Default setting: 128**

Parameter: X 20... 128, Number of characters before an auto linefeed.

Auto linefeed after X transmitted characters (word wrap). The auto linefeed is turned off with the value 128.

## 6.49 LIst Remote

Lists the contents of a directory in the PTC mailbox.

The short-form L for the LIst command is also accepted by the remote station, as in this case no possible confusion with LIsten can occur!
--

The output format is valid also for the **DIR** command (refer to chapter [6.36](#), page [79](#))

Examples:

## 6 Commands

---

<b>L DK5FH</b>	Lists all messages for DK5FH.
<b>L DK5FH 4</b>	Lists the message no 4 for DK5FH.
<b>L DK5FH 4-</b>	Lists from message no 4 onwards for DK5FH.
<b>L DK5FH 3-5</b>	Lists messages 3 to 5 for DK5FH.
<b>L ALL</b>	Lists all messages in the directory ALL.
<b>L ALL 4-5</b>	Lists the messages 4 to 5 in the directory ALL.
<b>L 5</b>	Lists message no 5 in the current directory.
<b>L</b>	List all messages in the current directory.

### 6.50 Listen

#### Default setting: 1

Parameter: 0 Listen mode disabled.  
1 Listen mode enabled.

The Listen mode is turned on with **Listen 1**, so that it is possible to 'Listen-in' to what is being sent in PACTOR QSO and to read Unproto transmissions. Listen is only possible in the STBY condition. If the Listen mode is active Connect packets are also monitored and displayed: [CONNECT-FRAME: CALL], e.g. [CONNECT-FRAME: DL6MAA] means that a station is trying to connect to DL6MAA. With poor signals it is possible that the CALL is displayed only partially because it couldn't be decoded correctly.

No Channel busy status is given in Listen mode.

#### 6.50.1 PACTOR-III

If the listen mode is activated (Listen 1), also PACTOR-III transmissions can be monitored. The tuning bar and the status LED's have the same function as in the connected case (ARQ connection), except the connected LED, which is not lit during monitoring. Hence, also the receive frequency error is displayed and the user can (carefully) adjust the frequency at the receiver in order to compensate for the frequency offset.

For achieving good monitoring results on PACTOR-III, the frequency offset should be kept lower than 20 Hz. Of course, an SNR appropriate for the actual "speedlevel" is necessary for error-free reception. Nevertheless, monitoring results are naturally inferior to ARQ connections under same conditions because no retries can be requested. Opposed to PACTOR-II monitoring, the sideband of the transmission is not detected automatically by the PACTOR-III monitor and thus must be chosen manually. As the vast majority of PACTOR-III connections utilize the upper sideband (USB), this is not a drawback in practice.

PACTOR-III unproto transmissions generated by firmware versions older than 3.3 cannot be monitored without missing packets because the packet timing is too tight. If PACTOR-III unproto is utilized for broadcast transmissions (received by PACTOR-III monitoring), firmware version 3.3 must also be used on the transmit side.

## 6.51 LOCK

**Default setting: 0**

Parameter: 0 Lock off.  
          1 Lock on.

With this command it is possible to protect PTC parameters against accidental change. **LOCK 1** switches the function on, **LOCK 0** switches it off.

The following commands are **not** affected by **LOCK**:

**CHeck, CLR, Connect, Disconnect, DD, DElete, DIR, HElp, LIst, Listen, LOCK, LOG, Qrt, Read, RESEt, Send, SHow, Unproto, Version, Write.**

## 6.52 LOG Remote

This command reads the PTC log entries. The last 16 PACTOR/AMTOR contacts are displayed (except Unproto contacts). The Log entries can only be erased with a **REStArt** (a total reset).

The following extra information in the callsign field is also available:

S1: PACTOR-I (Sysop call)  
S2: PACTOR-II (Sysop call)  
P1: PACTOR-I (Rx call)  
P2: PACTOR-II (Rx call)  
AT: AMTOR  
X1: Packet (AX.25) Port 1  
X2: Packet (AX.25) Port 2

AMTOR links are only entered in the Logbook after a successful **LOGIn!**

After the call the used scan channel (1-16) is displayed in a new column (CH) in the PTC-Log. If the scanner was not activated a 0 is displayed as scan channel. The extended log is only displayed if at least one of the shown connections was started out of a scan process of the PTC.

Packet-Radio entries begin with X (from AX.25) followed by the number of the port where the connect took place. The logbook entries are made only after a disconnect, so that by multiple simultaneous logged in users, the logbook entries might not appear in strictly chronological order.

## 6.53 LOGIn Remote

In order to allow access to the PTC mailbox in AMTOR, a user station must first Login using the **LOGIn** command e.g. **LOGI DL1ZAM**. The user's callsign is thus made available to the PTC mailbox. Only after a correct **LOGIn** can the AMTOR user station send, read or delete files from the mailbox. A successful **LOGIn** also writes the user's callsign into the Log book page.

**LOGIn** can also be used by the sysop. This allows the callsign of the other station to be entered into the PTC to enable full mailbox access, without the station having to go through the full **LOGIn** procedure. In PACTOR, this would be needed only in exceptional circumstances, as an automatic **LOGIn** is performed. The call of the other station is essential for the correct operation of the PACTOR QRT protocol, so that changes during a link could influence the QRT procedure.

In the STBY condition, **LOGIn** displays the call of the last connected station. This call will also be used for a Connect command without argument. An argument (call) after **LOGIn** can be used to preset a call for the next master-connect without argument.

With a remote access using PACTOR, a **LOGIn** command will cause an error message.

### 6.54 Mail

**Default setting: 0**

Parameter: 0 New messages not reported.  
          1 New messages reported on connect.

On connect, reports if new messages for the caller are at hand. Only messages that have not been already read by the caller are counted.

To report mail for the sysop that has not been read (filename = MYCALL), the Connected Mail LED is used. It blinks during STBY operation if a new, unread mail is available.

### 6.55 MARK

**Default setting: 1400**

Parameter: X 300... 2700, frequency in Hz.

Allows the adjustment of the mark frequency of the PTC-IIpro in 1 Hertz steps (internal resolution 0.25 Hz, using DDS). The frequency chosen with the **MARK** command is only used when the **TOnes** parameter is set to 2 (refer to **TOnes** command, chapter 6.96, page 109).

### 6.56 MAXDown

**Default setting: 6**

Parameter: X 2... 30, number of error packets before down-speed.

Selection of down-speed parameter for automatic speed changing. **MAXDown** determines how soon the system steps down to a lower speed but more robust mode during poor channel conditions (2=fast / 30=slow). Example: **MAXDown** 7, i.e. the PTC switches down after receiving 7 error packets in a row.

### 6.57 MAXErr

**Default setting: 70**

Parameter: X 30... 255, maximum number of retries or errors.

**MAXErr** defines the timeout value. When initially calling a station, this value sets the maximum number of sync packets that the PTC sends without a response from the other station (refer to **Connect** command, chapter 6.22, page 70).

When connected, **MAXErr** determines how many consecutive faulty blocks or controls are permitted before the connection is aborted \*\*\*TIMEOUT: DISCONNECTED. Request blocks or request controls are not interpreted as errors, and reset the error counter to zero.

In AMTOR, the timeout is automatically doubled, so that with the default setting (70), a total of 140 packets (63 seconds) will be transmitted, until the system times out and completely breaks the link. The re-phase timeout for AMTOR is fixed to 32 packets.

The value 255 disables the timeout and causes endless traffic. Never use this setting for unmanned operation!
---

### 6.58 MAXSum

**Default setting: 30**

Parameter: X 5... 60, maximum count for memory ARQ.

**MAXSum** is the timeout value for the memory ARQ counter. It determines the maximum number/sum of faulty packets that are summed up. If **MAXSum** is exceeded, the sums are deleted, since it can be assumed that crude errors have entered the sum, and that further summation of the packet will not restore it. The optimum value of **MAXSum** depends on the condition on the HF channel. The worse the condition, the higher should **MAXSum** be set in order to be able to pass any information at all.

### 6.59 MAXTry

**Default setting: 2**

Parameter: X 1... 9, maximum number of 'speed-up' attempts.

**MAXTry** determines how often the PTC repeats a packet with the next speed level during an attempt to 'speed-up' the transfer rate.

### 6.60 MAXUp

**Default setting: 4**

Parameter: X 2... 30, number of error free packets before up-speed.

Selection of up-speed parameter for automatic speed changing. **MAXUp** determines how soon the system steps up under good channel conditions (2=fast / 30=slow).

Example: **MAXUp** 3 i.e. the PTC switches to a higher speed after receiving 3 correct packets in a row.

## 6.61 MMode

**Default setting: 2**

Parameter: 0 ASCII mode with no compression  
 1 Huffman mode & Auto-ASCII, if necessary (Level I compression).  
 2 Full Level II compression with Huffman, Pseudo-Markov and run length coding and Auto ASCII if required.

The 8 bit ASCII mode allows to transmit all characters from 0 to 255 (8 bit), inclusive the IBM special characters. Defined special characters (e.g. Idle, CANGEOVER characters, etc). can be transmitted using the Ctrl-character (refer to chapter 6.26, page 74)

In the Huffman mode only the ASCII characters 0... 127 (7 bit) can be transmitted. To transfer certain IBM special characters (umlauts), the PTC converts these characters according to the following table:

Umlaut	ASCII	Transmitted Character
ä	132	14
ö	148	15
ü	129	16
Ä	142	20
Ö	153	21
Ü	154	22
ß	225	23

Table 6.2: Conversion of German special characters.

The Huffman data compression, which can improve speed up to 80% (effective character length 4.5 to 5 bit) allows to reduce the middle character length. The data compression of lowercase letters is better as for uppercase letters. The ASCII mode will be useful only if the text contains non ASCII characters, or many uppercase letters.

The PTC firmware scans through each packet determining whether HUFFMAN or ASCII coding will be more efficient for transmission, and selects the better one. Manually selecting the ASCII mode (**MMode** 0) makes the controller transmit ASCII anyway. Doing this should only be necessary in very special cases.

Automatic mode also works on characters exceeding 127 decimal. Therefore 7PLUS files may be transferred without any user intervention.

The parameter 2 is effective only with a PACTOR Level II link. With Level I contacts, the system behaves as if the parameter 1 had been chosen. The automatic compression used in PACTOR-II has proved to be very advantageous and reliable. Therefore, the

**Mode** parameter should only need to be changed in exceptional circumstances (e.g. measuring the text throughput without compression) to a value < 2. There are no problems caused by leaving the Level II compression turned on, even when transmitting 7Plus, binary files or graphics. No manual intervention by the operator is required, as the PTC-IIpro will switch automatically to uncompressed ASCII transmission for individual packets, if necessary.

### 6.62 MONitor

This command switches to AMTOR listen mode (Mode L). In AMTOR listen mode, an existing AMTOR ARQ link between two stations can be read on screen.

As the AMTOR listen mode requires a lot of computer time, it is not possible to receive any FEC transmissions or answer PACTOR or AMTOR connect requests in this mode! The PTC doesn't react on PACTOR or AMTOR ARQ connect requests.

By using the CHANGEVER character (refer to chapter 6.19, page 69), it is possible to re-synchronize at any time.

If the PTC does not switch back to letters, due to poor reception conditions, using <Ctrl> + <B> Ctrl-B> will force a letter shift.

### 6.63 MYcall

**Default setting: ROM-Callsign**

Parameter: CALL Station's callsign, 2 to 8 characters.

Defines the own Callsign. Whenever the callsign is received during STBY, the PTC performs slave synchronization and responds with a control signal attempting to establish the requested connect.

With an active AMTOR prompt **MYcall** sets one's own Selcall

Although there is a convention how to create a Selcall out of a callsign this procedure isn't always reasonable. Basicly an AMTOR selcall consists of 4 letters. From a normal call usually the first and the last 3 letters are used to assemble the selcall e.g. DK5FH → DKFH, DL3FCJ → DFCJ. If the call only contains 3 letters, the first one is used twice.

**MYcall** without argument returns the call or selcall as currently set.

After power-on the firmware checks if there is a valid setting for the PACTOR-MYCALL available. If it is the case (that means that the setting is different to \*SCSPTC\*) it copies the PACTOR-MYCALL into all PACKET-channels which still contain SCSPTC and replaces it by the valid MYCALL. The same procedure is performed if the **MYcall** command is executed with a valid call as argument in the **cmd:-**menu. This ensures that after a **REStart** or after the first power-on all calls are set to a valid value.

## 6.64 MYLevel

**Default setting: 3**

- Parameter:
- 1 The PTC-IIpro behaves as a Level I controller.
  - 2 The PTC-IIpro behaves as a Level II controller, and will switch to PACTOR-II when the other station is so fitted.
  - 3 The PTC-IIpro behaves as a Level III controller, and will switch to PACTOR-III when the other station is so fitted.

This command serves to maintain the highest possible PACTOR level. The parameter should only be set to 1 or 2 for test purposes. The default value 3 leads to a very reliable and automatic level choice procedure during the link initialization, so that the link always proceeds using the highest possible level. There are no disadvantages incurred by using this *auto negotiate* procedure.

**MYLevel1** without argument leads to a 2 line output. The first line displays the maximum possible link level (1...3, as set with **MYLevel**). The second line displays the link level of the current or last link. This may be useful if PC software wants to test in which link level PACTOR links runs or ran.

## 6.65 MYSelc

**Default setting: ROM-Selcall**

Parameter: ADDR Own selcall of the PTC.

It is identical to the **MYcall** command with activated AMTOR prompt, whereby under the **cmd:-**prompt the AMTOR selcall may also be defined. Without a parameter, the actual selcall is displayed.

## 6.66 NAVtex

Various arguments allow the complete configuration of the NAVTEX processor. A short run down over the possible arguments can as usual be obtained with the command

**cmd: HELP NAVTEX** <Return>

If the command **NAVtex** is given without argument, the PTC-IIpro displays the present configuration of the NAVTEX processor.

The two most essential things to be set up are:

- The maximum number of files allowed in the NAVTEX directory. If this number is greater than 0 then the NAVTEX processor is activated.
- The type of messages (A to L see above) that the NAVTEX processor should store.

The following default values are preset (for instance after a RESTART of the PTC):

- Number of AUTO-NAVTEX directory entries: 0 (AUTO-NAVTEX is DISABLED!)

- Selected NAVTEX area(s): ALL!
- Selected MESSAGE TYPES:
  - A: Navigational Warning
  - B: Meteorological Warning
  - D: Search and Rescue Info
  - E: Meteorological Forecast
  - L: Navigational Warning (2)

### 6.66.1 Activating the NAVTEX Processor

The NAVTEX processor is TURNED OFF as default, and must be first turned on to be used! It is easy to turn on, it is only necessary to give an argument between 1 and 200 after the **NAVt<sub>e</sub>x** command:

**cmd: NAV 100** <Return>

100 thereby defines the maximum number of files allowed in the NAVTEX directory and also activates the NAVTEX processor.

### 6.66.2 Setting the types of messages required

If the default setting is not appropriate to ones wishes, the message types can be set directly by typing the appropriate letter(s) after the **NAVt<sub>e</sub>x** command:

**cmd: NAV ACBL** <Return>

The example quoted will allow "Navigational Warnings", "Meteorological Warnings" and "Ice Reports" to be received. All other message types are ignored by the PTC. It is essential that no spaces are present between the letters. The order of the letters however is unimportant.

The argument "ALL" is a special argument which allows ALL message types to be received instead of typing in a long list of letters.

**cmd: NAV ALL** <Return>

The two arguments "*Maximum number of entries in the NAVTEX directory*" and "*List of letters for choosing the message types*" can be entered together. The order of input is of no importance. E.g.:

**cmd: NAV ABDE 50** <Return>

**cmd: NAV 70 CDEF** <Return>

**cmd: NAV ALL** <Return>

### 6.66.3 Choice of the message area codes

If one wishes to receive messages from a few special coast stations, these can be set by using the command **NAV AREA**. This can often be a useful choice, as a skipper in the Mediteranean Sea will have (presumably) no interest in navigational messages concerning

## 6 Commands

---

the North Sea or Baltic. The area codes allocated to the individual coast stations can be easily found out by inspecting the message contents.

If one wishes to receive messages from coast stations M, N and Z, then the PTC is informed of this with the command **NAV AREA** <Enter>.

**cmd: NAV AREA MNZ** <Return>

The order of the letters is unimportant. Again however, there should be no spaces between the letters.

The special argument "ALL" is also allowed here. The command

**cmd: NAV AREA ALL** <Return>

allows the reception of messages from all areas. The command

**cmd: NAV AREA** <Return>

without an argument displays the present area codes chosen.

### 6.66.4 Choosing the message latency time

A somewhat advanced setting possibility allows the PTC-IIpro to decide after what time period the message is no longer valid. This command is the argument "**DAYS**" which may follow the **NAVtex** command. It can contain a number between 0 and 365. This sets the time the message will be counted as valid. If a message is received containing the same four figure message identifier as a previously stored message, then the message is classed as a repetition when it is received within the latency period. If received outside the latency period, then the NAVTEX processor interprets the new message as a **different** one, and stores it without checking for errors as an independent message. The setting

**cmd: NAV DAYS 0** <Return>

turns off the NAVTEX processors automatic update, all messages are written consecutively in the NAVTEX directory, even when message identifier duplication is present. The default setting

**cmd: NAV DAYS 3** <Return>

is a practical value for continuous operation, and needs not normally be changed. The command

**cmd: NAV DAYS** <Return>

without argument displays the present "**NAV DAYS**" parameter.

### 6.66.5 AMTEX

The use and configuration of the AMTEX processor takes place using the NAVtex command. There now exists an additional parameter "**AMTex**". By using this parameter, one can switch between normal NAVTEX operation (**AMTex 0**) and AMTEX configuration (**AMTex 1**). The default **AMTex** parameter is 0. The PTC-IIpro is thus preconfigured for normal NAVTEX operation.

One switches to the AMTEX configuration with the command:

## 6 Commands

---

**cmd: NAVtex AMTeX 0** <Return>

As usual, it is only necessary to type the letters given in capitals, as well as the argument.

When the AMTEX configuration is switched on, the PTC-IIpro uses an entirely separate set of area codes and message types to those used by NAVTEX. The appropriate NAVTEX parameters are NOT changed in any way by activating the AMTEX configuration, and are stored separately. They remain untouched until the AMTEX mode is turned off, at which point they become available as usual for NAVTEX reception.

When the AMTEX configuration is active, the AMTEX message types and area codes can be changed as usual (e.g. "NAV XYZ" or "NAV AREA XYZ"). In AMTEX mode, the valid message types are from A to Z (NAVTEX allows only A - L). The AMTEX/NAVTEX processor uses the directory "AMTEX" instead of "NAVTEX" when in AMTEX configuration.

The following default values are valid for AMTEX:

```
Selected AMTEX station identifier(s): AS
Selected AMTEX MESSAGE TYPES:
-----
```

```
E: DX News Bulletin
G: General News Bulletin
K: Keplerian Data Bulletin
P: Propagation News Bulletin
S: Space Bulletin
X: Special Bulletin
```

```
*** AMTEX configuration: 1
```

### 6.67 NULI

#### Default setting: 1

Parameter: 0 Case switching disabled.  
          1 Case switching enabled.

This command only refers to the AMTOR side of the PTC!

The **SCS**-PTC supports the PLX-APLINK convention for case switching. This means that AMTOR files from the PTC, with upper and lower case letters, may be distributed throughout the worldwide APLINK network. Users with compatible systems can read these files in AMTOR, with upper and lower case letters.

The upper/lower case convention is activated with the command **NUL 1**. This method is fully compatible to the AMTOR system without case switching, but slightly reduces the already somewhat slow transmission speed.

Switching is disabled with the command **NUL 0**.

### 6.68 OFF

Switches off the PTC-IIpro. With signals on the RS232 link the (e.g. one or more <return>) it switches on again.

In *off-by-command* condition the PTT-LED of the packet-radio port 2 is blinking.

### 6.69 PACket

The **PACket** command, or **PAC** for short, switches on PTC-IIpro Packet radio commands, the input command prompt having the form **pac:**, and the Packet radio commands are then valid (refer to chapter 9, page 143).

The **PACket** command can also have a single command from the **pac:**-menu as argument. As with the other sub menus of the PTC-IIpro, it is also possible to pass through direct commands this way.

Switch of the Packet Radio listen – without entering the **pac:**-menu previously:

**cmd: PAC M 0** <Return>

**SCS** has developed different Packet Radio modules to be used with the PTC-IIpro. This modules only have to be inserted into the PTC-IIpro internal sockets, everything else is done from the PTC-IIpro automatically. Only the audio output level of the AFSK and FSK modules have to be adjusted manually with respect to transceiver used. The other settings are done comfortably by software.

- DSP-Packet-Radio-Module-II for:
  - 200 and 600 baud robust HF-Packet
  - 300 baud AFSK (modem tones are fixed to 2300/2100 Hz, *High-Tones*)
  - 1200 baud AFSK
  - 9600 baud FSK (direct FSK G3RUH mode)
  - 19200 baud FSK (direct FSK G3RUH mode)

The following Packet-Radio modules are **not** available any more:

- **SCS** AFSK module for 1200 and 2400 baud AFSK with modem chip TCM-3105 and completely digital carrier detection.
- **SCS** Highspeed module for the G3RUH compatible FSK method (9600 baud etc).
- DSP-Module for 300 and 1200 baud AFSK as well as 9600 and 19200 baud FSK (G3RUH).

For detailed information about installation and operation of the Packet radio modules refer to chapter 3.5, page 23 and chapter 9, page 143.

## 6.70 PDTimer

### Default setting: 12

Parameter: X 2... 30, PACTOR Duplex BREAKIN time in seconds.

Defines the PACTOR Duplex BREAKIN time. This is the minimum time the PTC has to be in IRS state (data receiving), until a BREAKIN is sent automatically in the case that own transmission data are available, and *takes the keys*.

The **PDTimer** value is only valid in the PACTOR Duplex mode (**PDuplex** is set to 1).

## 6.71 PDuplex

### Default setting: 0

Parameter: 0 PACTOR Duplex switched off.  
1 PACTOR Duplex switched on.

PACTOR Duplex offers an intelligent CHANGEOVER automatic. For further information about PACTOR Duplex refer to chapter 5.12, page 55.

## 6.72 Phase Remote

### Default setting: 0

Parameter: X -120... +120, phase correction in ppm.

Arguments are ignored when given from remote.

This command allows fine adjustment of the system clock, and displays the accumulated phase correction during a PACTOR contact. As an argument of the **Phase** command may be the correction parameter to the hardware clock in ppm (Quartz). For example, a system clock running 10 ppm too fast can be compensated by typing -10. The entered correction parameter becomes valid when the next PACTOR contact is started. During slave mode, the PTC software automatically issues the appropriate phase correction setting, so that exact synchronization between the master and slave station will be established within a few minutes after start of the contact, provided the initial clock difference did not exceed 30 ppm. When called without an argument, the actual total phase correction, manually and system-generated initial values, are displayed.

This is a powerful feature that you can use for aligning your PTC crystal oscillator, without any measuring instruments, following these steps. Perform a master call to a station with a known highly accurate PTC clock *frequency*. After at least five minutes of contact, you can read out the phase correction data from the reference station, by sending a remote control P command. Enter the phase correction data from the reference station as a new initial value for the Phase command, **inverting the preceding factor** (i.e. '-78' becomes '+78'). If a timeout occurs under 5 minutes, your system clock offset is probably too great to be compensated by the automatic phasing. In this case, the data readout will only show a tendency.

**6.73    POSition    Remote****Default setting: none**

Parameter:    NMEA    Requests NMEA raw-data.

When a GPS receiver is connected to the PTC-IIpro, its possible to readout the actual position using the **POSition-** command. The position information normally has the following format:

```

GPS POSITION REPORT
-----
Latitude:   50° 05.430' North
Longitude:  008° 45.980' East
Velocity:   0.0 Knots
Course:     360°
Recorded at: 13/12/00  19:25:48 UTC/GMT

```

The **POSition** command allows the argument NMEA.

**cmd: POS NMEA <Return>**

The PTC-IIpro in this case gives out the original NMEA compatible position string ("sentence") - exactly as it was received from the GPS receiver. NMEA compatible strings are "understood" by various navigational programs, and can thus be almost universally used. The NMEA compatible position string usually has the following format:

```
$GPRMC,212234,A,5005.432,N,00845.974,E,000.0,360.0,190201,000.1,E*7B
```

**6.74    PSKAmp1****Default setting: 140**

Parameter:    X    30... 3000, AF output voltage (peak to peak) in millivolts.

This command serves to set the AF output voltage (transmitted signal) of the PTC-IIpro for the DPSK modes (PACTOR-II ARQ and PACTOR-II Unproto). The DPSK signal of PACTOR-II has a variable envelope, the average power of which is approximately half the peak power. It is therefore necessary to be able to adjust the PSK signal amplitude separately from the FSK amplitude (refer also **FSKAmp1** command, chapter 6.42, page 81), in order that both forms of modulation should have the correct average power level. (A simple automatic adjustment of the PSK amplitude by a factor 1.45 does not give a satisfactory result, as the ALC control characteristics are different from transmitter to transmitter).

The input sensitivity of most transceivers is adjusted for the output level of an average dynamic microphone. With 200 mV (peak to peak) therefore, most transmitters would be fully driven with the microphone control only slightly open. It is not recommended to use

## 6 Commands

---

a very high **PSKAmp1** value, and then turn the MIC gain control right down, as the first AF stage is normally Before the gain control, and rather sensitive to overdriving. We recommend that the **PSKAmp1** value of 140 (the default setting) be left alone, and the PSK output to be increased with the microphone gain control (if available). The transceiver should be connected either to a 'dummy load' of appropriate power handling capacity, or a well matched antenna. (Please pay particular attention that the chosen frequency is really free. PTC-IIpro links operate even when the signals are so weak as to be virtually 'non existent!'). Use **U 3** <Return> to start the Unproto mode 3 (100 Bd DBPSK). Now, using the Mic gain control of the transceiver, the power is increased until the ALC voltage has reached the desired value.

Do not in any circumstances overdrive the transmitter, otherwise the signal will be made considerably wider due to intermodulation products!

When correctly adjusted, the peak power should be approximately the same as the PEP rated power output of the TRX. The effective average power is then approximately half the maximum power, so that continuous operation should pose no thermal problems. Note that many modern transmitters only show the peak power and this must then be taken into consideration. If the Mic gain control must be turned up over half way, then it is recommended the **PSKAmp1** value be increased. (By for example '<Esc> **PSKA** 200 <Return> '). If there is no Mic gain adjustment available, then naturally the PSK amplitude must be adjusted with the **PSKAmp1** command alone. The internal resistance of the AF output level of the PTC-IIpro is 330 ohm and real.

### 6.75 **PSKTerm**

Starts the PSK31 operation of the PTC-IIpro. For further information refer to chapter 11, page 191.

### 6.76 **PT**

Returns to PACTOR from the AMTOR, RTTY, PSK31 or CW modes. Activates the PACTOR input prompt (**cmd:**).

### 6.77 **PTChn**

**Default setting: 4**

Parameter: X 1... 31, hostmode channel for PACTOR.

Defines the hostmode channel for PACTOR, which can then only be used by a hostmode program on the channel defined here.

### 6.78 **Qrt** Remote

From the terminal side, identical to the Disconnect command. For a remote station, the **Qrt** command causes a CHANGEOVER, and the message:

```
hiscall de mycall>  
<qrt>
```

and then initiates a disconnect.

Note: The **Disconnect** command is not available from the remote side, because entering D is interpreted as the **DIR** command. This ensures compatibility to usual box systems.

### 6.79 QRTChr

**Default setting: 4 (Ctrl-D)**

Parameter: X 1... 127, ASCII-Code (decimal).

Sets the QRT character, which causes the system to go QRT (close the link). It can also be sent in the RX mode, which then becomes active at the next TX phase. In PSK31, RTTY, FEC and UNPROTO it switches from transmit to receive. It is an alternative to the **Disconnect** command, and can also be put at the end of a text to be transmitted, so that at the end of the transmitted text, the link is closed down.

### 6.80 Read Remote

This command is used to read out files from the personal mailbox. The remote controlled reading of files may be broken off with a CHANGEOVER. If Read is used by the sysop in the connected condition, then this does not cause a transmission of the chosen file (refer to the **send** command, chapter 6.86, page 101).

- R** Reads message no 1 in the current directory (if only 1 message exists).  
Outputs the contents of the current directory if more than 1 message exists.
- R 3** Reads message no 3 in the current directory.
- R 3-6** Reads messages numbers 3 to 6 in the current directory.
- R TEST 3** Reads message number 3 in the TEST directory.
- R DL2FAK** Reads message no 1 for DL2FAK if only one message exists.  
Outputs the contents of the DL2FAK directory if more than one message exists.
- R DL2FAK 1-3** Reads messages numbers 1 to 3 for DL2FAK.
- R PTCPLUS 4-** Reads from message number 4 onwards in the PTCPLUS directory.

### 6.81 RELOad

**RELOad** overwrites the present BBS contents!!

**RELOad** enables a BBS backup file to be read back into the BBS. After the **RELOad** command, the PTC waits for a valid Backup file. As soon as the PTC receives a correct header (###PTCBAK), it begins to load the BBS file. The **RELOad** procedure is

## 6 Commands

---

prematurely aborted if the fileheader is faulty or if the file is too large for the RAM fitted. It is impossible to reload a PTC backup of 2 M RAM into a PTC with 512k RAM even if there is no message in the box. But it is not a problem to reload the PTC backup of a 512k RAM into a 2 M RAM of a PTC, for example after the installation of a RAM extension.

At the end of the loading procedure, the PTC performs a checksum comparison, and then gives a message saying whether during the **BAKup/RELOad** procedure an error had occurred or not. The **RELOad** procedure can then be ended with a Plus (+) character.

### 6.82 REMote

#### Default setting: 1

Parameter: 0 Remote control disabled.  
1 Remote control enabled.  
2 Remote control enabled to the TRX command set.

This command permits the access to the remotable control commands for a distant station. With **REMote** 1 the remote commands are enabled. The other station can now use all the commands signified with Remote . All these commands must, however, have the remote control characters // prefixing the commands (e.g. //Write test or //Dir).

The remote sequence "/" must be placed at the beginning of a new line, to be valid.

The **REMote** command should be set to 0 for 7plus transmission.

Also, directly after a connect, or CHANGEVER to receive, the PTC-IIpro is internally at the beginning of a new line, and thus processes the directly following // sequence as a remote control sequence, this limitation of only being accepted at the beginning of a new line increases the data transparency quite considerably.

Multiple remote control commands are allowed. Each command must end with a <CR>. A single command does not need the <CR> to end it, if a CHO character immediately follows the command. System messages of the remote controlled PTC are transmitted in lower case, as this gives better Huffman compression, and a clearer display.

**REMote** 2 additionally enables the full transceiver-control command set. All TRX commands as **TRX** <TRX command> at **BOX**=1 or //TRX <TRX command> at **BOX**=0 is available. The user has the chance to receive the frequency list of the PTC-IIpro, including the capability of changing the transmit frequency or modifying the channel list (e.g.

'TRX S 0' or //TRX S 0' stops the scan function) with the command //TRX L or //TRX C.

The Remote control access may be blocked with **REMote** 0.

### 6.83 RESEt Remote

Soft reset of the System!

This command may be used at any time and causes an uncontrolled disconnect while connected! The parameters entered and the PTC mailbox, as well as the log, are not deleted.

## 6.84 REStart

Causes a complete re-initialization of the PTC to factory defaults

This command may be used at any time and causes an uncontrolled disconnect while connected! Customized parameters are replaced by the defaults from the ROM, and the mailbox messages, as well as the log, are erased.

## 6.85 RLe

**Default setting: 1**

Parameter: 0 Run length coding off.  
          1 Run length coding on.

**RLe** allows the automatic run length coding for PACTOR-II links to be switched off (0), or to be reactivated (1). This command is usually only used for testing purposes (speed comparisons etc). and is only implemented for completeness.

## 6.86 Send Remote

The **Send** command operates exactly the same as the **Write** command for remote operation (for compatibility with other mailbox systems).

The **Send** command, whilst connected, allows the sysop to send a file to the other station. All additional information concerning the file (File header, EOF text, path text) is suppressed, so that, for example, station descriptions and other fix texts may be received as per the original on the screen of the other station.

**Send**, in the disconnected condition, is identical to the **Read** command. Again here, all extra information (file header, EOF text, path text) is suppressed.

## 6.87 SERBaud

**Default setting: auto**

Parameter: baudrate The serial interface of the PTC-IIpro is pre-set to the given baud rate.  
          auto Automatic baud rate recognition.

Sometimes it is recommended to avoid the automatically baud rate recognition of the PTC-IIpro. This is for example the case if the PTC-IIpro (and the whole station) is switched on and off by a timer. Also if you want to make the PTC-IIpro react on a hostmode program after switching on you have to set the baudrate to a fixed value.

The **SERBaud** command allows the PTC-IIpro to be set to a certain baud rate and to avoid the automatic baud rate recognition after switching on the PTC-IIpro. The PTC-IIpro doesn't display AUTOBAUD / press CR, but will start directly!

To set the baud rate to 9600, just enter the following command:

**cmd: SERB 9600 <Return>**

At the next power-on the PTC-IIpro will come up with a baudrate of 9600 baud!

The following baud rates are known and could be recognized by the PTC-IIpro:

2400, 3600, 4800, 7200, 9600, 12000, 14400, 16800, 19200, 28800, 38400, 57600, 76800, 115200.

Example:

To activate the automatic baud rate recognition again enter the following command:

**cmd: SERB auto <Return>**

Switching on the PTC-IIpro the next time the automatic baud rate recognition will work.

The automatic baud rate recognition works from 2400 baud and higher!

Without entering arguments the **SERBaud** command shows the actual baud rate. The message “auto” will be added if the automatic baud rate recognition is turned on.

For further information refer to chapter 3.2, page 11 (Serial Interface) and chapter 6.39, page 80 (ESCchr).

### 6.88 SFile

The **SFile** command (send file) works exactly as the Send command, except that the additional information (file header, EOF text, Path text) is not suppressed. The **SFile** command is not available from the remote station.

### 6.89 SHow Remote

**Default setting: None.**

Parameter: A (ALL) displays all parameters.  
C (CHARACTERS) displays all the control character settings.  
P (PARAMETERS) displays the system parameters.  
B (BUFFER) repeat of the last 12288 characters entered.

ATTENTION: **SHow B** is disabled for Remote operation.

The **SHow** command without parameters displays the present link parameters. The slave response time is only shown if the PTC is acting as Master (i.e. the station that has initiated the QSO). The slave response time is defined as the time between the last send bit (bit end) and the start of the first receive bit. In CW terminal mode, the present CW receiving speed is displayed instead of the link parameters. In case of a PACTOR-II link, the measured frequency deviation is additionally given.

**SH** could show the following:

```
Number of RECEIVED packets / control-blocks:
TRAFFIC:           2 / 5
```

## 6 Commands

---

```
REQUEST:      0 / 0
ERROR:        0 / 0
MEMO-ARQ:    0 / 0
```

```
SLAVE RESPONSE TIME (MS): 58
```

The link parameters remain stored after the QRT, so that evaluation may be made after the QSO.

**SHoW C** shows information on all the control character settings of the PTC. It is thus quick and easy to see if essential characters have been changed.

```
QRT-CHARACTER = ASCII: 4
ESCAPE-CHARACTER = ASCII: 27
CONTROL-CHARACTER = ASCII: 22
CHANGE-OVER-CHARACTER = ASCII: 25
BREAK-IN-CHARACTER = ASCII: 25
```

**SHoW P** displays the essential system parameters. The timing for the transceiver control and the parameters that influence the link quality are shown.

```
CS-DELAY: 5
TX-DELAY: 4
*** TIMEOUT-PARAMETER: 70
*** SPEED-DOWN-PARAMETER: 5
*** SPEED-UP-PARAMETER: 4
*** SPEED-UP-TRY-PARAMETER: 2
```

In CW mode the **SHoW** command displays the present CW receiving speed.

### 6.90 SPAcE

**Default setting: 1200**

Parameter: X 300... 2700, frequency in Hz.

Allows the adjustment of the space frequency of the PTC-IIpro in 1 Hertz steps (internal resolution 0.25 Hz, using DDS). The frequency chosen is only used when the **TONes** parameter is set to 2. (refer to chapter 6.97, page 110).

### 6.91 SQuelch

**Default setting: 45**

Parameter: X 0... 99, Value for the noise suppression.  
100... 200, used for ZCZC/NNNN autostart.

The trigger point for the software squelch (noise suppression) for Baudot RTTY can be set using the **sQuelch** command, with values between 0 to 99. With the value 0, the squelch is always open (noise-suppression turned off). With the value 99 the squelch is always closed (all signals suppressed). With a value of about 40, the squelch remains closed on a totally free channel, but is very sensitive to changes in the signal spectrum on that channel. Even very weak and noisy RTTY signals should correctly open the squelch,

## 6 Commands

---

when it is set to the standard value of 45. An open squelch is displayed on the PTC front panel by either the Idle or Traffic LED lighting (depending on the received RTTY signal).

Coastal radio stations or other professional RTTY stations normally send the character string ZCZC in advance to a new message. The end of a message is followed by the character string NNNN.

This can be used to make a *Start/Stop* squelch available. If ZCZC/NNNN is activated the PTC-IIpro receive in the Baudot/RTTY mode only if the pattern ZCZC is found in the data stream. As commercial radio stations only send for a short time at a day, using this special (digital) squelch can reduce the accidental *received* QRM drastically.

The ZCZC/NNNN autostart can be activated setting the squelch parameter to a value between 100 and 200. If the squelch value is set to 140, the PTC-IIpro operates with the ZCZC/NNNN autostart and additionally with the normal analog squelch of 40 (value minus 100). This means that also during open autostart squelch the reception is interrupted, if the signal falls below a certain level.

### 6.92 SStatus

#### Default setting: 1

Parameter: 0 Status checking on (see text).  
          1 Status checking on.  
          2 Status checking on (automatic status output).

The status word polling in the PTC-IIpro is permanently turned on. The parameter 0 has only been retained for compatibility reasons.

The status word polling in the PTC-IIpro is permanently turned on. The status command has only been retained for compatibility reasons. Any argument is ignored.

This command facilitates polling of all operational states of the PTC via the serial interface. This is useful for mailbox systems, or more luxurious terminal programs.

The status byte is called by the RS character (ASCII decimal 30). This definition of the status request byte does not impose any restrictions on data transparency. PACTOR uses ASCII 30 (decimal) as the *idle byte* which can only be transmitted via a supervisor sequence.

The PTC's status reply always begins with an echo of the RS character (ASCII decimal 30) to facilitate unique identification of the status information following. The actual status byte follows this *header*.

This modular status level concept facilitates an expansion of the status information in the future, i.e., in a higher status level, even several bytes containing status information can be implemented. The status bytes (incl. header) are sent in direct sequence.

During the transmission of status information new status requests are ignored.

The status information is processed totally independent from the current XON/XOFF state of the serial interface.

## 6 Commands

In status mode 2, the PTC-IIpro has an automatic status output. This means that the status no longer needs to be regularly polled by the terminal program. Instead, every status change causes the status information automatically to be given. The status output is in the usual format: 30, S (S = status-byte). In status mode 2, the status byte can still be polled via the terminal as before, for instance directly after the start of the terminal program.

Hints for programmers: Through the PACTOR software the status reply may be delayed by 150 ms. After a system boot (power on, **REStart**, or **RESEt**), the status polling is ready after the first **cmd**:-prompt. Construction of the status byte (status-level 1):

Bit	7	6	5	4	3	2	1	0
Meaning	1	MODE			D	STATUS		

**Bit 7** always 1 to avoid control codes (XON/XOFF, etc).

**Bit 3** (DIRECTION bit) reflects the state of the SEND LED. This bit is 1 when the PTC is the packet sender.

The fields mode and status have the following meaning:

Bit			STATUS-Bits	Remark
2	1	0		
0	0	0	ERROR	
0	0	1	REQUEST	
0	1	0	TRAFFIC	
0	1	1	IDLE	Idle byte in packet, does not exclude traffic bytes in the packet!
1	0	0	OVER	The system is busy with a CHANGEOVER. ERROR, REQUEST, TRAFFIC, and IDLE are ignored.
1	0	1	PHASE	AMTOR only.
1	1	0	SYNCH	Active immediately after first half of a selcall or the first 4 decoded PACTOR address bytes.
1	1	1	IGNORE	Status currently not defined (e.g. STBY).

Table 6.3: PTC status information, Bit 0-2

Bit			MODE-Bits	Remark
6	5	4		
0	0	0	STANDBY	
0	0	1	AMTOR-ARQ	
0	1	0	PACTOR-ARQ	Active no more than 20 ms after the end of the SYNC sequence in the received SYNC packet, or for a MASTER start no later than the begin of the data packet.
0	1	1	AMTOR-FEC	
1	0	0	PACTOR-FEC	
1	0	1	RTTY / CW	
1	1	0	LISTEN	AMTOR or PACTOR.
1	1	1	Channel-Busy	RF channel busy.

Table 6.4: PTC status information, Bit 4-6

In *STBY* condition the PTC-IIpro analyzes the HF channel and differs between *busy* and *free*.

A *busy* channel is defined as all signals that are audibly distinctly different from noise, but, however, having a speed < 250 Baud. Packet-Radio (300 Baud) is virtually ignored. Furthermore, strong carriers on the channel are not evaluated as *channel busy*. Even the very hard to detect PACTOR-II signals were recognized. The PTC-IIpro reacts well even to short QPSK/BPSK sections, so that even the short PACTOR-II acknowledgement signal is sufficient for the channel to be recognized as busy.

This function is essential for automatic stations, e.g. **WinLink** systems.

An occupied HF channel is indicated by a status value of 247 (Channel busy) being given over the serial interface. After the PTC-IIpro channel busy status has been activated, it remains so for at least 3.5 seconds. An optical output is also given, with the TRAFFIC LED lighting up when the channel is busy.

The Channel busy status is only given in the *STBY* condition, and **not** in Listen mode (L=1)!

### 6.93 SYStest

The system test is not normally required by the PTC user, but has been included here for the sake of completeness. *SYStest* is purely a tool to diagnose and rectify faults in defective PTCs!. In normal operation this function is not needed.

The command **SYStest** (without argument) activates the system-test menu. (**sys:-menu**). The command prompt takes the form **sys:**.

Within the **sys:-menu** the following systemtest commands are allowed:

**Audio, AUDPerm, Beep, DD, Down, Fsk, Help, Kill, Led, Ptt, PLL, Ram, SERNum, Up, Quit.**

All other *normal* commands are not available! The **sys:-menu** may be ended with **Quit** or **DD**.

The **SYStest** command may also be followed by an argument, which should be a command from the **sys:-menu**. In this case, the PTC carries out only that given systemtest command, without switching to the **sys:-menu**. The command virtually has been fed through.

This command for example would show the PTC-IIpro RAM expansion.

**cmd: sys Ram** <Return>

For a detailed description of the *SYStest* commands see chapter 12, page 195.

## 6.94 Term

### Default setting: 0

- Parameter:
- 0 Simple terminal mode.
  - 1 Terminal mode with delayed echo.
  - 2 Split screen terminal mode.
  - 3 Enhanced split screen.
  - 4 Split screen with command prompt recognition.
  - 5 Split screen also for Packet-Radio.

With this command it is possible to make the PTC-IIpro support split screen terminals.

In **simple terminal mode** text is not sent to the terminal when the PTC receives commands from the user. The text stream is interrupted by the first command given. At maximum 2000 characters are stored. The terminal must have local echo (halfduplex).

**Terminal mode 1** is for use with simple split screen terminals. The incoming text, and the text to be sent out, should be displayed in separate windows on the screen. All transmitted characters are echoed by the PTC, as soon as they are transmitted and correctly confirmed by the station the PTC is connected to (delayed echo).

In **terminal mode 2** the PTC completely controls the switchover between the windows on the screen. Therefore the screen is divided in two areas. In the upper area the system information of the PTC and the text to be transmitted appears. The lower window shows the received text and the delayed echo-text. The PTC sends Ctrl-A as a changeover character to the TX/information window and Ctrl-B as a changeover character for RX/delayed echo window. The windows should be scrollable independently.

**Terminal mode 3** arranges the delayed echo to be signaled by a Ctrl-C, not a Ctrl-B as it is in terminal mode 2. The normal RX text is still signaled by a Ctrl-B. This convention makes it possible to divide the screen into three parts. The first window (Ctrl-A) for system information and TX text, the second window (Ctrl-B) for RX text and the third window (Ctrl -C) for delayed echo text.

**Terminal mode 4** differs from TERM 3 in that the PTC sends a Ctrl-D before every command prompt. TERM 4 considerably eases the terminal programming, in that the continuous search for prompts (**cmd:**, **\*\*--A--\*\***, etc) is no longer required. Also, the PTC always sends a pseudo prompt when the command interpreter is closed again (on Connect, on switching to the CW or RTTY modes, etc.). This contains only a <Ctrl-D>, followed by a <CR>, thus complete control over the (command) input window is maintained, and there is no ambiguity concerning the <CR> sent from the PTC. It is recommended that the <CR> from the keyboard, signaling the end of a command, is not shown as local echo in the input window, but just ignored. This minimizes unnecessary empty lines in the input window.

In **terminal mode 5**, PR data, link status messages, monitor information etc is always preceded with a Ctrl-F. Only direct answer messages for a command input do not fall under this convention. This allows the comfortable administration of PR multi connects etc. using a non hostmode terminal.

## 6 Commands

---

All PR received data is sent **at once** to the terminal program without bothering about the **Setch** command (refer to chapter 9.6.34, page 164). **Setch** only has influence on the present transmit channel in terminal mode. This means that one must set **Setch** to 2 if one wishes to transmit data via channel 2. (If for instance an external link from the PTC-IIpro has been automatically given channel 2 and one wanted to write a text to that other station.) Terminal programs that fully support Term 5 must therefore also administrate the **Setch** command.

After Ctrl-F, follows the channel number (binary, increased by 48) and then the codebyte, as is defined in WA8DED hostmode:

Code Byte	Meaning
0	Success, no text follows (Not used in Term 5)
1	Success, text follows (Not used in Term 5)
2	Error, text follows (Not used in Term 5)
3	Link status info follows (CONNECTED to... etc).
4	Monitor header follows / no monitor data
5	Monitor header follows / monitor data available
6	Data from the monitor follows
7	Data from the link follows

Table 6.5: Code byte description

The terminal mode 5 also extends the command prompt. Every command prompt, as in terminal mode 4 is preceded with a Ctrl-D. after every Ctrl-D however, follows a byte with prompt information. Bits 5-7 contain coded information about the prompt sort:

Bit 7	Bit 6	Bit 5	Prompt	Bits 0-4
0	0	0	Not allowed	-
0	0	1	<b>cmd:</b>	0=cmd, 1=AMTOR, 2=MONITOR, 3=RTTY, 4=CW, 5=PSK31
0	1	0	<b>trx:</b>	always 0
0	1	1	<b>sys:</b>	always 0
1	0	0	<b>aud:</b>	always 0
1	0	1	<b>pac:</b>	present input channel (0-31)
1	1	0	<b>rcu:</b>	always 0
1	1	1	<b>fax:</b>	always 0

Table 6.6: Prompt coding

The bits 0-4 contain additional information, depending on the actual prompt. After the prompt codebyte it follows as usual the text prompt information, ended with a Ctrl-A.

The **pac:**-prompt contains the channel number of the presently set input channel (**Setchn**) as plain text information before the colon. (Channel numbers of two digits are thus output by two ASCII number characters.)

The prompt information of terminal mode 5 cannot be split. I.e. no other information can be pushed through between bytes. The prompt always begins with a Ctrl-D and always ends with a Ctrl-A.

**6.95 TIme** Remote**Default setting: none**

Parameter: HH:MM:SS Desired time.

Arguments are ignored during remote control.

**TIme** is used to set or read the internal clock.If **TIme** is entered without a parameter, the current time is displayed.

When the clock is set, leading zeroes must not be omitted. The colons can be omitted. Wrong entries cause a wrong programming of the clock chip.

Setting the clock to 9 o'clock 56 minutes and 5 seconds

**cmd: TI 09:56:05**

or

**cmd: TI 095605.****6.96 TNC****Default setting: 0**Parameter: 0 Simple PTC terminal mode.  
1 TNC mode with Ctrl-A echo.  
2 TNC mode with Ctrl-A echo and \*-prompt.

hostmode terminal programs are developed for pure PR controllers (TNC) with **The-Firmware** (TF) as firmware. But some properties of the simple command structure suggested by the **WA8DED** are not suitable for a modern multimode controller. Thus TF uses as prompt only an asterisk \* - this is for a system with many submenus (e.g. PTC-IIpro) not very supportive. For example the PTC-IIpro displays in the main menu **cmd:.** Switching to a submenu the prompt changes, so that the user has the advantage to know directly which menu is selected.

Some hostmode programs test exactly if a controller with TF is connected – most of all to determine if the used controller is already in the hostmode or still in the terminal mode. For this purpose, as response to the ESC character the asterisk prompt is expected. In the normal mode the PTC does not send the asterisk prompt, because the ESC character is responded with its own prompt (e.g. **cmd:**).

Programs like **SP** or **TOP** will never switch to the hostmode but simply stop the initialization phase. Without a workaround this programs could not be used with the PTC-IIpro. This workaround is represented by the TNC command.

Using this command, the PTC-IIpro, up to the desired extend, adapts its behaviour to react similar to the **WA8DED** command interpreter. The PTC-IIpro reacts similar to a normal TNC if the TNC command is activated. This causes somewhat incompatibility to the own standard, but the necessary adaptations are tolerable.

## 6 Commands

---

Description of the parameters:

0. normal PTC terminal mode, PTC-IIpro prompt as usual.
1. As long as the PTC is not in the hostmode, the character *Ctrl-A* is always echoed. As it is unlikely in the terminal mode that a Ctrl-A is sent to the PTC, this is not really a restriction or incompatibility. (Binary data has to be transferred using hostmode). But the echo of the Ctrl-A character is necessary when using **WinGT**. Unfortunately without these echo **WinGT** will idle a minute after startup. But with TNC set to 1 there won't be a waiting period and the program starts immediately. If **TOP** or **SP** are not used the PTC-IIpro can always be operated with the TNC set to 1.
2. The PTC-IIpro shows the same behavior as in the TNC 1 mode, but additionally the prompt will be altered to asterisk \*, i.e., the PTC answers to a ESC character not with the **cmd:**-prompt but with the asterisk. This setting has to be used to operate the PTC-IIpro with **TOP** or **SP** as the terminal. Unfortunately sometimes the Asterisk collides with other terminal programs expecting the **cmd:**-prompt. With **PlusTerm** or programs similar to this the TNC parameter should be set smaller than 2.

To work in a very comfortable way with all these programs (without having to execute the TNC command) it is recommended to add the command TNC 0 within the PTC initialization file of non-hostmode programs (e.g. STARTUP.PTC for **PlusTerm**). Using this option the PTC will work as a normal PTC independent from how it was used before and will provide the prompt that the non-hostmode terminal programs expect.

Similar to what is described above, one can add the command TNC 2 into the de-initialization file (e.g. SHUTDOWN.PTC for **PlusTerm**) of the non-hostmode program, so every hostmode program can be started without problems afterwards.

### 6.97 TOnes

**Default setting: 0**

- Parameter:
- 0 Low tones (1200/1400 Hz).
  - 1 High tones (2300/2100 Hz).
  - 2 Freely adjustable tones - definable with Mark - Space commands.
  - 3 PACTOR-III tones 1200/1400 Hz
  - 4 Standard PACTOR-III tones 1400/1600 Hz
  - 5 PACTOR-III tones 1600/1800 Hz

The **TOnes** command allows the PTC-IIpro to be switched between two preset Low tone or High tone standards, or to freely adjustable tone frequencies. The two tones are used for FSK as well as PSK operation.

## 6 Commands

With PSK operation, care must be taken that the difference between the two tones is exactly 200 Hz, to remain compatible with the PT-II standard.

There is nothing, however, against experimenting with a chosen partner station with different shifts. It should be noted, however, that shifts greater than 200 Hz cannot be used with a narrow IF filter.

A PACTOR connection will only switch to PACTOR-III during link establishment if the TOnes parameter is greater than 2! We generally recommend to use TOnes 4 - also for PACTOR-I/II connections. Furthermore we recommend to work PACTOR-III only on the upper sideband (USB).

Please also note that the audio passband, i.e. the occupied audio spectrum, of the PACTOR-III signal always is fixed at 400-2600 Hz and INDEPENDENT of the TOnes setting. Regarding PACTOR-III, TOnes does ONLY define the (connect) tones used during link establishment, it does NOT define the relative location of the audio passband. If you want to adjust the audio passband, you can only do that by using the “passband tuning / IF shift” (or similar) at the radio!

Both systems participating in a PACTOR-III connection MUST definitely use the same TOnes parameter - otherwise a link will not work properly!

A description of the parameter follows:

- 0 Low tones  
1400 Hz = Mark frequency.  
1200 Hz = Space frequency.  
If **TR** = 0 (default), in RTTY and AMTOR the TRX must be set to USB operation.
- 1 High tones  
2100 Hz = Mark frequency.  
2300 Hz = Space frequency.  
If **TR** = 0 (default), in RTTY and AMTOR the TRX must be set to LSB or FSK
- 2 The freely definable **MArk** and **SPAcE** tones are used. We recommend **TR** to be set to 0 and to operate using USB, whereby the Mark frequency should always be higher than the Space frequency. Using this convention allows the higher AF, as well as the higher *HF frequency* to represent the Mark condition, and Logic 1 in RTTY and AMTOR With PACTOR, the shift direction plays no part in the decoding, as the correct relationship is always obtained at the start of the link.
- 3 PACTOR-III  
1200/1400 Hz  
Call (dial) tones for PACTOR-III link setup
- 4 PACTOR-III (recommended setting)  
1400/1600 Hz  
Call (dial) tones for PACTOR-III link setup
- 5 PACTOR-III  
1600/1800 Hz  
Call (dial) tones for PACTOR-III link setup

**6.98 TR****Default setting: 0**

Parameter: 0 TX and RX shift normal.  
 1 Only RX shift reverse.  
 2 Only TX shift reverse.  
 3 TX and RX shift reverse.

Only valid for RTTY and AMTOR.

Inverts the TX and RX audio shift (mark and space tones).

**6.99 TRX Remote**

The **TRX** -command (without argument) activates the transceiver remote control menu (**trx:-menu**). The command prompt takes the form **trx:.** The following transceiver control commands are allowed within the **trx:-menu**:

**Channel, DD, Down, DUmp, DWell, Frequency, Help, List, Offset, Ptime, Rtype, Scan, TImer, Transfer, TYpe, Up, Quit, Wait, XGate, XScan, YType.**

All other (*normal*) commands are not available from within the **trx:-menu**. The **trx:-menu** may be closed either with **DD** or **Quit**.

The **TRX**-command may also contain an argument, this being a suitable command from the **trx:-menu**. In this case the PTC will then carry out this command, without switching to the **trx:-menu**. The control command may be said to be fed through.

This command, for example, would change the frequency of a connected transceiver directly to 14079.0 kHz - without having to divert to the **trx:-menu**.

**cmd: TRX** Frequency 14079.0 <Return>

For a detailed description of the **TRX** commands refer to chapter [13](#), page [199](#).

**6.100 TXDelay****Default setting: 4**

Parameter: X 1... 16, PTT delay in X • 5 msec.

Sets the TX keying delay (x times 5 ms). The TX keying delay (TXDelay) is the time between activating the PTT and the sending of the first data.

## 6.101 Umlauts

### Default setting: 1

Parameter: 0 No umlaut in Huffman.  
1 German umlauts in Huffman.

With **Umlauts**, the umlaut convention (for German umlauts) for Huffman coding is activated or de-activated. The coding table is described in the **Mode** command. Usually the activated umlaut convention is used, as this considerably increases the transmission speed of German plain-language texts. The very often occurring umlaut is then being transmitted within a Huffman packet.

Unfortunately, within the ranks of PTC clones, there is equipment that cannot convert the umlaut (multimode controllers from the USA). In order to remain compatible with these systems, the PTC allows the umlaut coding table to be turned off.

## 6.102 Unproto

### Default setting: 1\*2

Parameter: 1... 10, Transmission mode for Unproto operation.  
30...41  
\*1... 5 Number of packet repetitions.

This command allows the transmission of broadcasts (CQ calls etc). in PACTOR without acknowledgment from the receiving station(s). An optional parameter sets the baud rate, and the number of repetitions of packets, in the transmission. This parameter can be set according to prevailing conditions.

Set the number of packet repetitions to 3.

**cmd: U \*3 <Return>**

Now, with the following command a 200 baud transmission can be started.

**cmd: U 2 <Return>**

Unproto possibilities for PACTOR-I:

Parameter	Speedlevel	Packet definition
1:	100 Bd FSK	(standard method for Level I CQ calls)
2:	200 Bd FSK	

## 6 Commands

---

Unproto possibilities for PACTOR-II:

Parameter	Speedlevel	Packet definition
3:	100 Bd DPSK	(short cycle) (standard method for <i>Level II only</i> calls)
4:	200 Bd DPSK	(short cycle)
5:	400 Bd DPSK	(short cycle)
6:	800 Bd DPSK	(short cycle)
7:	100 Bd DPSK	(long cycle)
8:	200 Bd DPSK	(long cycle)
9:	400 Bd DPSK	(long cycle)
10:	800 Bd DPSK	(long cycle)

Unproto possibilities for PACTOR-III:

Parameter	Speedlevel	Packet definition
30:	1	short cycle
31:	2	short cycle
32:	3	short cycle
33:	4	short cycle
34:	5	short cycle
35:	6	short cycle
36:	1	long cycle
37:	2	long cycle
38:	3	long cycle
39:	4	long cycle
40:	5	long cycle
41:	6	long cycle

If no argument is given, then the PTC-IIpro uses the mode that was last used, or the default setting. The actual mode is shown on the LED status field.

The Unproto mode may be terminated with a QRT character, a **Disconnect**. It is always possible to abort a unproto transmission using the command **DD**.

A repetition rate of 3 does not mean that the text appears on the screen of the receiving station 3 times. In this case, the PTC increases the redundancy of the signal by repeating it. The transmission takes longer, but there is a correspondingly greater chance of receiving it correctly. At the receiving station, once a packet is correctly received, it will not be received again. A data packet may be repeated 3 times, but will only appear once at the receiving station(s). It is recommended that the repetition rate should be adjusted according to propagation conditions. A greater repetition rate, and lower baud rate, for poor conditions, and conversely a lower repetition rate, and higher baud rate, for better conditions.

After approximately 4 minutes of idle transmissions, an automatic QRT is carried out.
---

### 6.103 UPDATE

The **UPDATE** command renews the PACTOR firmware in the Flash ROM of the PTC-IIpro. It should only be used together with the corresponding program on the PC, which

automatically performs the update procedure with all necessary handshake and control mechanisms.

### 6.104 **USer** Remote

The **USer** command enables an overview of all presently operating PTC-IIpro links. Here the PTC-IIpro gives out the callsign of the opposite station, as well as the digipeater list etc. In contrast to the **CStatus** command in the **pac:-**menu, the **USer** command also lists an operating PACTOR link, under channel number 0. (This channel is free, as the PR channel 0 only serves as a *monitor channel* and thus no link is possible).

### 6.105 **USOs (Unshift On Space)**

**Default setting: 0**

Parameter: 0 Unshift on space disabled.  
            1 Unshift on space enabled.

Has effect only on RTTY reception. With **USOs** switched on, every received space character sets the Letter/Figures shift to Letters. This has the advantage that the manual shift switching (<Ctrl-B> or <Ctrl> + <B>) required with weak or noisy signals, (to mitigate the figures printed due to a false Figures shift being received, or Letters shift being missed) can be virtually dispensed with. The long strings of numbers often received from DX stations, instead of the actual text, is now virtually a thing of the past. A problem can however occur with a switched on **USOs**, when a string of figures are received with only a space character in between, and the transmitting station fails to send a new Figures-shift after the space, to denote that the next character(s) are figures.

### 6.106 **VERIfy**

This is identical to the **RELOad** command, except the BBS file is NOT loaded into the PTC. The checksum is calculated instead so as to check the file integrity, without destroying the BBS contents.

### 6.107 **Version** Remote

Shows a short version and copyright message:

```
PTC-IIpro System / written by H.-P. Helfert (DL6MAA)
Version V.2.8 (C) 1994-99 SCS GmbH - Germany
```

### 6.108 **Write** Remote

**Default setting: none**

Parameter: Filename File or directory name.  
            Title Optional title of the message.

From remote the same function is also available as **send** command.

Enables files to be sent to the PTC mailbox. The end of the file is indicated, in the case of direct input from the terminal, by an ESCAPE-Character (refer to **ESCchr**, chapter 6.39, page 80). In the case of a remote station sending a file via PACTOR to the mailbox, the end is indicated either by a CHANGEOVER, <Ctrl-Z>, or NNNN. In AMTOR, the end of the file is indicated by the CHANGEOVER (+?), or NNNN. An ESCAPE character from the sysop breaks off the remote controlled file input. The remote control sequence '/' may be contained within files, as, during the file input, the sequence has no meaning.

The **write** command may also contain two parameters: **write filename** [title]. The *filename* is essential for mailbox operation. The *filename* is the name of the subdirectory in which the message will be stored. If this is missing, then the PTC reacts with a message: **\*\*\* missing filename**. The message can additionally be given a title. The title is not necessary, and can be left out. Contrary to most Packet-Radio mailboxes, the title is not automatically requested!

Stores a message for DL3FCJ (without a title).

```
cmd: w DL3FCJ <Return>
```

Stores a message for DL1ZAM entitled 'Board Layout'

```
cmd: w DL1ZAM Board Layout <Return>
```

Stores a message for DL6MAA entitled 'This is a test'.

```
cmd: w DL6MAA This is a test <Return>
```

The last example shows that the title could be more than one word. The whole text after the *filename* is interpreted as the title of the message. The length is limited to 32 characters and additional characters are cut off.

Filenames identical to a filename number (1-, 2, 2-3, etc). are not allowed and an error message will occur in this case.

### 6.109 XUser

The **XUser** command is used to manage the user list.

The PTC-IIpro firmware allows to define user specific access priorities, i.e., that it is possible to define in a user list if for example the user DK9FAT is permitted to use the PR→PACTOR gateway or if he is allowed to read private messages for other callsigns from the Packet side, etc.

Up to 64 entries are possible in the user list. The first entry is always assigned to the *callsign* ALL and defines which priorities are given to the users being not part of the list.

Example for a typical user list:

```
User Priorities /PR-BOX/PT-BOX/PR-GATE/
=====
ALL.....2220  DL1ZAM...9999  DL6MAA...3330  DL2FAK...3330
DK9FAT...2230  DL3FCI...2230
```

## 6 Commands

---

Each entry consists of the user callsign and a four-digit character string indicating the assigned priorities. At the moment only the first three characters are used, the fourth one is reserved for future extensions. The first three characters define the priorities for 1. mailbox access from PR side, 2. mailbox access from PACTOR side and 3. usage of the PR→PACTOR gateway.

A detailed description of the priorities is omitted for the moment. The following functionality is available:

PR-Box priority:      Smaller 3: only reading of own and public files is possible  
                            Larger or equal 3: reading of all files is possible

PT-Box priority:      Smaller 3: only reading of own and public files is possible  
                            Larger or equal 3: reading of all files is possible

PR-GATE priority:    Smaller 3: Access to the PR→PACTOR gateway is denied  
                            Larger or equal 3: Free access to all gates is provided

Detailed information will be available in later versions.

Concerning to the user list and the details explained above users being not covered by the list are, e.g. not able to use the PR→PACTOR gateway, because the PR-GATE priority for the *callsign* ALL is 2. On the other hand the user DK9FAT is able to use the PR-GATE, but has no access to foreign private files.

The **XUser** command is used to manage the user list. **XUser** has various functions depending on the kind and number of added arguments:

**XUser** without argument

Displays the complete user list.

**XUser** ----

Deletes the user list and sets the priority of the *callsign* ALL to default (3330).

**XUser** CALLSIGN

Displays the priority assigned to the callsign CALLSIGN.

The length of callsigns could be up to 8 characters but in practice they should not be longer than 6, because in PR the length is limited to 6 characters by the protocol. Callsigns extensions, e.g. F/DL6MAA/M are inadmissible and not useful because of incompatibility with the PR protocol. The PTC-IIpro cuts all characters appearing after a *special character* in the callsign automatically. From the entry DL6MAA-10 is automatically DL6MAA generated. The entry of a SSID in the callsign list is not possible.

With the help of the "wildcard" \* groups of callsigns can be defined (e.g. XU DO\* 0000). Priorities without the "wildcard" in the callsign dominate, e.g. XU DO1XXX 333 has priority despite the DO\* entry in the user list. "Wildcards" can be used for example to suppress illegal access to the PR → Pactor gateway.

**XUser** CALLSIGN -

## 6 Commands

---

Deletes the callsign CALLSIGN from the user list. The PTC-IIpro confirm that with "OK". The entry ALL cannot not be deleted!

**xUser CALLSIGN xxxx**

Sets the priority for the callsign CALLSIGN to the value xxxx. The numbers 0-9 are allowed for each character within xxxx, e.g. 1330. No spaces between the numbers are allowed. If less than 4 digits are defined, the PTC-IIpro automatically adds a 0 at the missing positions. The PTC-IIpro confirms with "OK".

The user list has no limiting effect for entries from the console.

## Chapter 7

### 7 Audio

The Audio-denoiser-menu (**aud:-menu**) is activated with the command **Audio**. The command prompt takes the form **aud: .**

The following commands are available in the **aud:-menu**:

**Bandwith, Center, CWfilter, DD, Delay, Help, Invert, Level, Notch, Peak, Quit, Through, TOne.**

All other (*normal*) commands are not available in the **aud:-menu**! **Quit** or **DD** exit the **aud:-menu**.

The commands of the **aud:-menu** in detail:

#### 7.1 Bandwidth

**Default setting: 300**

Parameter: X 30... 1000, Bandwith in Hz.

Adjusts the -6 dB bandwidth of the CW-filter continuously between 30 and 1000 Hz. (Refer also to command **CWfilter**, chapter 7.3).

#### 7.2 Center

**Default setting: 1400**

Parameter: X 300... 2700, center frequency of the CW-filter.

Sets the center frequency of the CW-filter continuously between 300 and 2700 Hz. (Refer also to command **CWfilter**, chapter 7.3 and the command **CWTerm**, chapter 6.30).

The **Center** command also adjusts the audio frequency of the CW-Terminal (chapter 6.30) of the PTC-IIpro send and receive sides. (In firmware releases prior to version 1.12, the CW-Terminal used the current Mark-frequency, which sometimes was not particularly suitable).

#### 7.3 CWfilter

Activates the CW-filter, using the center frequency set by the **Center** command, and the bandwidth set by the **Bandwidth** command.

The filter is designed as FIR with a linear phase-change, so that even with a bandwidth of 30 Hz it does not ring. The transfer function has not been designed for maximum edge steepness, but a shape delivering a signal easily readable for the human ear, and the best signal/noise ratio possible.

## 7.4 DD

Terminates the **aud:**-menu.

## 7.5 Delay

**Default setting: 100**

Parameter: X 0... 1500, delay in ms.

Defines the delay time between the Audio-IN (socket X5, PIN 4) and Audio-OUT (socket X5, PIN 1) signal.

## 7.6 Help

Lists all commands used in the **aud:**-menu.

## 7.7 Invert

**Default setting: 3000**

Parameter: X 3000... 4500, inversion frequency in Hz.

Activates the Audio-inverter to change LSB to USB and USB to LSB. The inversion frequency is normally set to 3000 Hz. An optional argument allows adjustment of the inversion frequency between 3000 and 4500 Hz..

Audio-inverter with an inversion frequency of 3600 Hz

```
aud: Invert 3600 <Return>
```

## 7.8 Level

**Default setting: 50**

Parameter: X 0... 100, output level of the audio-amplifier.

The **Level** command sets the volume of the internal audio amplifier which supplies the speaker that can be connected to the PTC-IIpro.

## 7.9 Notch

Activates the automatic N-times notch filter. All systematic signals are heavily attenuated. The algorithm used leads to considerably less signal distortion of speech signals compared to simpler DSP notch filters.

### 7.10 Peak

Activates the automatic N-times peak filter. This may be considered as a phase-linear Auto-Correction filter, of a very high order and large dynamic range. This filter enables slow CW-signals within the SSB bandwidth to be found that lie **below** the level discernible by the human ear. The filter algorithm puts a very narrow band filter on all systematic signal components. Uncorrelated noise is heavily attenuated.

### 7.11 Quit

Terminates the **aud:-**menu.

### 7.12 Through

Loops through the Audio signal direct, i.e. without filtering, from the input (ADC) to the output (DAC).

### 7.13 TOne

**Default setting: 1000**

Parameter: X 1... 5000, frequency in Hz.

Starts the sine wave generator. The frequency required is given as an argument for the command. The range covers 1 Hz to 5000 Hz with a resolution of 1 Hz. The command without an argument delivers a tone of 1000 Hz.

The command can also be used to setup a dual tone generator. For this, the second frequency is entered after the first one, separated by a space. Both tones are generated simultaneously, which is well suited for measurements of intermodulation distances of transmitters and power amplifiers.

Example:

```
aud: TO 1000 2000 <Return>
```

generates a two-tone signal of 1000 **and** 2000 Hz the same time.

The amplitude may be set using the **FSKAmpl** command from the main menu (refer to chapter [6.42](#), page [81](#)).



---

## Chapter 8

### 8 FAX

#### 8.1 General Information

In addition to the normal teletype modes the PTC-IIpro supports the following modes; FM-FAX (Shortwave), AM-FAX (Satellites), SSTV (All present standards) and NFSK-Demodulation for decoding various shortwave teleprinting methods.

The algorithms used here, profit from the relatively high computing power of the PTC-IIpro and allow the system to easily reach the theoretical limits regarding definition, filter performance and resistance to interference in all picture operating modes. Additionally, particular for STTV, a new concept for recognizing and filtering the synchronization impulses has been incorporated. With the use of DSP techniques, the system delivers excellent linearity, both in the receive and transmission paths. This means very good color rendering and reproducibility. A possibility for manually setting the filter bandwidth and maximum picture definition allow the user to adjust for actual signal conditions.

Transmit operation is also supported for FM-FAX/FSK, AM-FAX and SSTV. The FM/FSK modulator is phase-continuous and highly linear, producing an extremely clean transmitted signal.

The FM/FSK demodulated signal is available as a 1 bit square wave at PIN 6 of the RS-232 interface in addition to the usual 8-bit serial transfer. This allows full compatibility with the widely used radio teleprinter programs such as Zorns Lemma.

The PTC-IIpro operates in all special MODEM functions as a FULL-DUPLEX modem. This means the appropriate demodulator generates the correct data even during the transmit phase. This is in most cases however, only of interest for testing purposes.

#### 8.2 Basic info concerning FAX and SSTV

##### 8.2.1 AM-FAX

This FAX variant is found mainly in the typical VHF/UHF/SHF FM frequencies, despite the fact that one tends to think of AM as a shortwave mode. In practice, AM-FAX is an FM transmission, but is concerned with the transmission of an amplitude modulated low frequency carrier. The frequency of the carrier tone is normally 2400 Hz. The instantaneous amplitude relates to the brightness information. When the tone is at its maximum amplitude, then the receive program must paint a white pixel. When the tone is very soft, then a black pixel must be displayed. (NOTE: with FM, the loudness of the transmitted signal has no relation to the strength of the received HF-signal).

The most interesting signal sources of AM-FAX are mainly the weather satellites (NOAA-Satellites on 137 MHz or the geostationary Meteosat 5 or GOES (USA) on approx. 1.7 GHz.

To receive these satellites, it is recommended that a special receiver is used with an IF bandwidth of approx. 30-50 kHz. For the 1.7 GHz band, a small dish or Yagi-antenna with a low noise LNA or LNC will also be required.

Meteosat 5 for example, transmits almost continuous IR and VIS pictures with a resolution of 2.5 to 5 km in a format of 800 x 800 pixels. Many programs are able to automatically sense the beginning of each picture by using additional digital information, and to make very impressive weather films. These films are interesting not only for amateur meteorologists, but also for sailors, mountain climbers etc.

The pixel-rate from Meteosat 5 is 3360 pixels per second - 4 lines are transmitted per second. The resulting bandwidth (relating to the appropriate Nyquist filtering) is  $\pm 1680$  Hz or a total of 3360 Hz. The PTC-IIpro allows the maximum possible resolution of the Meteosat signal to be displayed.

### 8.2.2 FM-FAX

Frequency modulated FAX is the established standard for weather maps and press photographs on shortwave and longwave. This very old *WEFAX-Standard* is however rapidly losing importance in the commercial sector. One reason is that the quality of the FAX image is strongly influenced by the effective signal to noise ratio and the propagation conditions (e.g. multipath propagation). In amateur use however, FM-FAX is a useful mode as it allows high definition in comparison to SSTV, for transmission of highly detailed pictures on good to very good HF paths.

The center frequency for FM-FAX has established itself as 1900 Hz. On longwave, a frequency shift of 150 Hz is usual. On shortwave it has standardized at 400 Hz. This means that in a normal FAX signal on shortwave, the brightness information *white* is transmitted by a tone of 1900 + 400 Hz i.e. 2300 Hz, and "black" is represented by 1900... 400 Hz or 1500 Hz. A gray-scale is given by the appropriate frequencies between the limits represented by 1500 and 2300 Hz.

The Nyquist bandwidth associated with FM-FAX is approximated by the formula  $\text{pixelrate} + 2 \cdot \text{shift}$ . With a pixelrate of 1600/sec, one calculates a Nyquist bandwidth of  $800 + 400 + 400 + 800 = 2400$  Hz. The PTC-IIpro allows a resolution of up to 2600 pixels/sec. The bandwidth of such a signal is approximately 3400 Hz, so that a steep sided 2.4 kHz SSB filter would be too narrow to allow the full resolution to be used. It is only useful to increase the receiver bandwidth above 2.4 kHz when it is known that the transmitted bandwidth is not limited to 2.4 kHz. Here only trial and error will tell if the received picture resolution is improved with a wider receiver IF bandwidth.

The majority of FM-FAX transmissions are carried out with a speed of 120 lines per minute, however 90 and 60 lines are also used by various agencies for special purposes. The speed may be guessed, with a bit of practice, from the sound of the signal from the station loudspeaker. If one is not sure, then it can be found by counting (for example for half a minute) the typical rhythmical beat of the FAX transmission.

The start and end of an FM-FAX transmission is usually signaled by a long (several seconds) tone sequence. This method is called APT, which means nothing more than Automatic Picture Transmission. FAX-Programs can evaluate these APT tones automatically.

FM-FAX signals may be found all over the shortwave bands, and are easily recognized by their typical rhythmical and somewhat *rough* tone. The receiver should be set to USB for FM-FAX reception, so that the correct relationship between brightness and frequency information is maintained. (If the wrong sideband is chosen then the pictures are *inverted*, i.e. black lines are drawn white and vice-versa).

### 8.2.3 SSTV

With use of a computer creeping into virtually every shack, the SSTV mode has changed from a technical challenge for a few specialists, to a relatively wide-spread and amusing amateur radio pastime. Above all it is also interesting for *epicures in private* to observe the large number of SSTV transmissions on 20 and 80 m. In the early days of SSTV, it was only possible to transmit relatively low definition Black and White pictures. The new generation of SSTV standards, under good propagation conditions, offer an astoundingly good, high resolution, true-color picture. In the last few years, two variants have established themselves as de-facto standards. **MARTIN 1** in and around Europe, and **SCOTTIE 1** in the US and US-influenced areas of the world. Both standards are very similar, and differ only in small details.

In order to allow high definition and also color transmissions to be made, the new standards have a transmission time of approximately 2 minutes per frame (as against only 8 seconds for the original Black/White SSTV pictures).

One of the main problems of the old *steam SSTV* was the persistence of the CRT on which the pictures were viewed. In this digital age, with electronic storage, the problem is no longer there. The developer has more or less a free choice, and is virtually only dictated by the wishes of the user.

Unfortunately, this freedom in transmission times has led to an unnecessary number of different SSTV sub-standards, some of which are poorly documented. A real technical requirement for these multiplicity of standards is not to be found. By limiting the SSTV practice to a few modes, it is possible to keep a reasonable overview of the entire SSTV scene.

Like in the early *steam SSTV* period, the modern systems still use FM as the means for video transmission, very similarly to the FM-FAX standard (refer to chapter 8.2.2, page 124). The center frequency is usually 1900 Hz, with a shift of 400 Hz, so that as in FM-FAX, the frequency limits are 1500 Hz and 2300 Hz representing the *black* and *white* respectively.

The difference between FM-FAX and SSTV is that SSTV uses picture and line synchronization in the form of a special tone frequency which is *blacker* than *black*, that is 1200 Hz. A tone-burst with a frequency of 1200 Hz and a duration of 30 ms signals the start of a picture frame. At the start of every SSTV line, a tone of 1200 Hz with a duration of 5 ms is inserted as a horizontal synch pulse, so that the exact start of a line can be marked. The exact and rapid processing of this horizontal synch pulse is the key to satisfactory SSTV reception.

The resolution of MARTIN 1 and SCOTTIE 1 is approximately 300 pixels per line. The color palette is obtained by mixing the colors red, blue and green. Every line transmitted actually consists of three lines, each containing the intensity components of the respective

colors. Effectively, each line contains three *sub lines*. When using this transmission system, incorrect tuning does not lead to color errors. It leads instead only to changes in color intensity.

SSTV signals are often found in the band segment 3730-3740 kHz, as well as 14230 and 14240 kHz. After a short period of getting used to things, the sound of SSTV, as in all other forms of picture transmission, is rapidly recognized by its distinctive sound from the station loudspeaker.

### 8.3 FAX and SSTV with JVComm32

As with **WIN95** the real-time processing is not reliable enough, **JVComm32** also had problems using the PTC SSTV/FAX transmission routine at slower PCs. For transmission the PTC needs a continuous data stream with a high baud rate (usually 57600 baud) from the PC's serial interface. No interrupt should occur, as gaps and shifts within the transmitted picture would be the result. But a continuous data stream using **WIN95** is only possible with very fast PCs – and also this is no guarantee – it depends on the computing capacity occupied by other applications.

The second problem of the older implementation: The transmission timing must be provided by the PC. But PCs only use inaccurate and unadjusted oscillators so a relatively complicated procedure for skew correction on the transmission side was necessary.

Both problems are solved with the new modem command **JVComm** within the **fax:-**menu, activating a new transmission routine. On the receiving side the JVComm modem of the PTC-IIpro has the same behavior as the previous FMfax modem (also activated within the **fax:-**menu). The only difference is that the PTC provides no receiving data while the JVComm modem of the PTC-IIpro is in transmission state. That means that no full-duplex with loop back is possible.

The JVComm transmission routine provides a buffered data exchange with handshake. This dramatically reduces the real-time requirements of Win95. The PTC transmits data exactly with a rate of  $1/20 * \text{Mbaud rate}$  on the HF side (DSP modem). Because the data rate on account of the 10 steps/byte at the serial interface could be at a maximum  $1/10 * \text{Mbaud rate}$ , the PC has a lot of time to fill the transmission buffer of the PTC.

#### 8.3.1 Specifications

**PTC-data buffer size** over all: 13312 byte

**Handshake** (RTS, PIN 8 at the SUB-D-9 socket of the PTC)

- Activated (=XOFF, -10 V) at: 8000 byte or more in the buffer
- Deactivated (=XON, +10 V) at: 6000 byte or less in the buffer

After XOFF the PC could still send about 5000 bytes without causing a buffer overflow.

**Output data rate:** exactly  $1/20 * \text{Mbaud rate}$

A skew correction usually is not necessary because the PTC-IIpro quartz is adjusted up to some ppm.

### 8.3.2 Reference of databytes concerning the PTC

Value	Reference	
0-240	Normal, linear frequency transmission data	0 = 1500 Hz 24 = 2300 Hz
241	Sync tone	1100 Hz
242	Sync tone	1200 Hz
243	Sync tone	1300 Hz

The values 0-243 trigger the PTT and the transmission mode of the JVComm modem. As soon as one of these bytes is received, the PTC usually switches to transmit and keeps this condition for  $(2500 * 1/\text{data rate})$  seconds (re-triggerable). At a modem baud rate of 57600 baud the TX tail has a length of 0,868 seconds.

244-250	Reserved for future extensions (no functionality, bytes are ignored)
251	Activates the phasing LED at the PTC front panel.
252	Deactivates the phasing LED at the PTC front panel (Direct analysis, not via data buffer). This LED can be used during the receiving operation to signalize sync pulses etc.
253	Deletes the transmission data buffer and shortens the TX tail to 0. (Direct analysis, not via data buffer). This command can be used to terminate a picture.
254	Deletes the transmission data buffer and shortens the TX tail to 0. (Analysis via data buffer). This byte defines the regular end of a picture. It must be added to each picture to deactivate the transceiver directly after picture end.
255	Ends the JVComm modem. Jump to the STBY mode of the PTC (Direct analysis, not via data buffer).

### 8.3.3 LED functions

#### Receiving mode

The LED behavior is the same as in the Fmfax modem.

But it is possible to control the phasing LED from the PC side with the data bytes 251/252.

#### Transmission mode

- Send LED active.
- Phasing LED active, as long as the data byte processing is in the range of 241-243.
- Traffic LED active in the XOFF state.
- LED's of the tuning indicator. Data byte 0=left-corner, data byte 240= right-corner.

#### Important Note:

The JVComm transmission routine of the PTC-IIpro is supported from the JVComm32 version newer than 0.96c beta by JVComm32.

It is possible to download JVComm32 in the internet from the JVComm-WWW-Site <http://www.jvcomm.de><sup>2</sup>.

### 8.4 Fax:-menu commands

When in the main-menu (**cmd:-**prompt), the **FAX** -command leads to the **fax:-**menu. The menu announces itself only with the prompt **fax:** (the description **fax:** is misleading because within this menu additional modes are available). In the **fax:-**menu the following commands are available:

**Amfax, Fmfax, Jvfax, JVComm, Sstv, Fsk, Comparator, PR300, AGain, AResolut, FResolut, SResolut, FSKBAud, Deviation, MBaud, SMode, TXcomp, HSynch, JSynch, ASynch.**

All other (*normal*) commands are not available in the **fax:-**menu! **Quit** or **DD** exit the **fax:-**menu.

All commands in the **fax:-**menu may also be carried out from the main menu, by setting the prefix **FAX** before the actual command.

**cmd: FAX JV FAX <Return>**

This is corresponding with the usual convention of the other sub-menus, e.g. **sys:-**menu or **trx:-**menu.

The **fax:-**menu consists of two basic types of commands, the *MODEM* commands and the *PARAMETER* commands.

The carrying out of a Modem command sets the PTC-IIpro into the actual FAX/SSTV/AUX modem function. It loads the appropriate new routines into the signal processor, adjusts the tuning indicator to the new function and at once starts passing the demodulated signal to the RS-232 interface - which may have had its baud rate changed during the Modem command, refer to the **MBaud**-Parameter command.

The MODEM operation of the PTC-IIpro can be ended at any time by inputting a byte with the value 255 (dec). via the RS-232 port. It is essential to use the correct baud rate (see **MBaud**-command!). After the ending of Modem operation, the PTC-IIpro announces itself with the normal **cmd:-**prompt, and is at once in the main menu. The baud rate is automatically returned to the value it was before the Modem command was called.

The PARAMETER commands are used for setting the various values needed for the particular Modem mode chosen, e.g. the actual baud rate during Modem operation (**MBaud**), the deviation for FM-FAX (**Deviation**), or the internal amplification for AM-FAX (**AGain** parameter).

---

<sup>2</sup> Be aware of that Internet addresses may change frequently

The Parameters must be set before the start of the chosen Modem function! During MODEM operation, the Parameter commands are not available; only the change of particular operating parameters in the operating mode **JVFAX** is possible using special control-codes (refer to the **JVFAX** modem command).

Note concerning the data-rate during MODEM operation:

The received data is sent with the maximum possible speed to the serial interface in all MODEM operating modes. There are no pauses between the individual characters, not even through excessive use of the Packet-Radio function of the PTC-IIpro multi-tasking. With an **MBaud**-rate for example, of 57600 bits/sec, there is a new value available for the connected PC approximately every 170  $\mu$ sec (10 steps of 1/57600 sec per step). A guarantee of modem data synchronization over a long period, cannot however be given.

Connects in Packet-Radio from outside are also possible during active MODEM functions without restrictions. Receiving data will be buffered as far as buffer is available.

### 8.5 The PTC-IIpro as COMPARATOR-MODEM

The PTC-IIpro is capable to be used as a simple COMPARATOR-Modem. This allows compatibility to all at present available RTTY/FAX/SSTV programs that allow use of a *simple modem* (e.g. HAMCOMM modem). The operation as a COMPARATOR is completely different to that of the other MODEM variants of the PTC-IIpro. In the normal MODEM operation (**Amfax**, **Fmfax**, **SSTV** commands), the DSP undertakes the demodulation of the signal itself, and uses relative complex algorithms. In the COMPARATOR mode, it is only used as an adjustable pre-filter (bandpass filter, **Fresol** command). The prefiltered signal is then only hard limited, and passed to PIN 6 (DCD) of the RS-232 interface. The actual demodulation must be undertaken by the PC program, so that considerable differences in quality may occur.

### 8.6 MODEM commands in detail

Activating the MODEM commands is the task of the displaying programs on the PC, e.g. JVCOMM32 or MSCAN. They are not intended for direct user access. If somebody tries to call for example SSTV out of terminal programs like PlusTerm, he will be punished with the output of a never ending data stream of hex characters ☺

#### 8.6.1 Amfax

Starts the AM-FAX-MODEM. The measured amplitude of the 2400 Hz tone frequency is given over the RS-232 interface at the rate set using the **MBaud** command.

The time-resolution required, and filter bandwidth may be pre-set using the **AResolut** parameter. The internal amplification may be pre-set using the **AGain** parameter. The output values reach from 0 to 255. Measured values greater than 255 are limited to 255 by the PTC-IIpro. (The data width is limited to 8 bits by the serial format.) With an AF input

amplitude of 500 mV, and a standard setting of **AGain** (50), the PTC-IIpro gives an output value of 255. With an input of 250 mV the output value is appropriately 128.

The tuning indicator displays the output values. The lower signal values lie to the left, the greater to the right.

For transmission use when using AM-FAX, refer to chapter 8.7.1, page 134 and chapter 8.7.1, page 134.

### 8.6.2 Fmfax

Starts the FM-FAX-MODEM. The measured *instantaneous* signal frequency is sent via the RS-232 serial interface, at the rate set by the **MBaud** command.

The time-resolution required, and filter bandwidth may be pre-set using the **FResolut** parameter. The *steepness* of the FM-detector may be pre-set using the **Deviation** parameter. The output values reach from 0 to 255. Measured values smaller than 0 are output as 0. Values greater than 255 are limited to 255 by the PTC-IIpro. The center frequency is exactly 1900 Hz. With a frequency of 1900 Hz as AF input, the PTC-IIpro always gives out the appropriate value of 128. With the standard setting of 400 Hz shift (Deviation = 400), then an output value of 255 is obtained with an input frequency of 2300 Hz, and the input frequency of 1500 Hz gives an output value of 0.

The tuning indicator displays the output values. The *left-hand limit* represents 1500 Hz (by the standard setting of 400 Hz shift) and the *right-hand limit* 2300 Hz.

For transmission use when in FM-FAX operation, refer to chapter 8.7.1, page 134.

### 8.6.3 Sstv

Starts the SSTV-MODEM. This MODEM resembles very closely the FM-FAX-MODEM (see Fmfax- MODEM command). It consists of an FM detector with a center frequency of 1900 Hz and a pre-set shift of 400 Hz. (Independent from the Deviation-Parameter). The Black and White limit frequencies are appropriately 1500 and 2300 Hz. The maximum possible resolution and input filter bandwidth may be pre-set using the **SResolut** parameter.

Unlike the FM-FAX-Modem, values smaller than 0 (measured frequency lower than 1500 Hz) or greater than 255 (measured frequency higher than 2300 Hz) are not just limited to 0 or 255. In SSTV, It has been found advantageous to *fold-back incorrect* values into the correct area. If the system, for example, measures a frequency of 2700 Hz, then it does not give out a value of 255. Instead, the output value is calculated using the formula

$$255 - (2700 - 2300) / 800 * 128.$$

This *folding-back* has been shown to give less color errors in *multipath* propagation conditions, and with other interference conditions. As the tuning indicator also displays the output values in SSTV-Modem operation, this *folding-back* can perhaps be somewhat confusing during tuning operation.

The SSTV synchronization pulse using a frequency of 1200 Hz is filtered independently from the FM-Detector, and is processed with the help of a relatively complex threshold

value method. Basically, the PTC-IIpro interprets these pulses as being a separate amplitude modulated signal, independent of the picture information. As a special new development, the PTC-IIpro can use a processing method especially designed for the line synch-pulse, that virtually accumulates the information over a number of lines. As this processing algorithm requires the line synch-pulse timing for correct operation, there exists a special command (**SMode**), with the help of which the PTC-IIpro is informed of the current SSTV sub-mode being used. The multi-line check may be turned off, which deteriorates the synch recognition, but however, does allow *unknown* SSTV-transmissions to be processed without problem when a good signal to noise ratio is available.

The PTC-IIpro uses the standard given in the **JVFAX** documentation, to pass the recognized synchronization pulses to the PC program. The system uses the lower two bits of every byte to indicate the synch pulse. Bits 0 and 1 are set to 1 in the resting state. As soon as the PTC-IIpro recognizes a correct synch-pulse on the 1200 Hz frequency, it sets the bits 0 and 1 to 0 for the time the synch-pulse occurs. (Note: the VIS code is at present not processed by the PTC-IIpro, and therefore bit 2 is actually redundant for the signaling condition.) The small decrease in color resolution caused by only having 6 bits to signal brilliance information can, in practice, be ignored.

The JVFAx sync method used by the PTC may be turned off using the **JSynch** parameter command. In theory, the PTC-IIpro may be used with the JVFAx in the operational condition **LSB-SSTV-SYNCH NO**. Then the system uses the full 8 bit data width for picture information. The practical results however speak against using this method.

With the **JSynch** parameter turned on (default setting), the recognized synchronization pulse is signaled to the user by using LED's:

Line synch-pulses are shown by the PTC-IIpro with a short blink of the Phasing-LED (red). A vertical synch-pulse (picture new start) lights the Connected-LED (yellow) shortly. A small time offset of the line-synch pulse may be set by use of the **HSynch** parameter. This allows the whole picture to be shifted slightly left or right.

For transmission use when in SSTV-MODEM operation, refer to chapter [8.7.1](#), page [134](#).

### 8.6.4 Jvfax

Starts the JVFAx mode. This mode does not contain its own Modem as such. Instead, it offers a sort of "*springboard*" to FM-FAX, AM-FAX and SSTV by using special control sequences, that are recognized in this mode by the PTC-IIpro. Directly after switching to JVFAx operation, the PTC-IIpro is in Modem mode FM-FAX, using a shift which has been preset using the **Deviation** parameter (normally 400 Hz). In addition to the actual operating mode, the PTC-IIpro's matrix display also shows the characters JV as its first two characters, signaling that control sequences will be accepted.

The following *1-Byte commands* are accepted by the PTC-IIpro when in JVFAX mode:

Byte	Function
\$49:	Switches to AM-FAX
\$4A:	Switches to AM-FAX
\$4B:	Switches to SSTV
\$41:	Switches to FM-FAX with 150 Hz shift
\$42:	Switches to FM-FAX with 200 Hz shift
\$43:	Switches to FM-FAX with 300 Hz shift
\$44:	Switches to FM-FAX with 350 Hz shift
\$45:	Switches to FM-FAX with 400 Hz shift
\$46:	Switches to FM-FAX with 500 Hz shift

Table 8.1: JVFAX Control Bytes

All shift settings done via the control sequences changes the shift for the moment (*local*). The value of the **Deviation**-parameters remains unchanged.

### 8.6.5 JVComm

Starts the JVComm modem of the PTC-IIpro.

Entering no argument the PTC-IIpro displays the string **JVComm32**. Any string can be entered for the display. The first character of the argument will not be displayed, it only marks the start of the string, this makes it possible to enter blanks in the display.

The string TESTFAX can be entered in the display in the following way:

**fax: JVC** : TESTFAX <Return>

At a maximum 10 characters can be displayed. In the example the colon has the function to mark the beginning of the string (started with a blank). The colon will not be displayed.

### 8.6.6 FSK

Starts the NFSK-Modem. This is very similar to the FM-FAX demodulator. This detector however is designed for a very much slower data rate compared to the FM-FAX detector. The input bandpass-filter can be considerably narrower than that for FAX operation. The base-band low-pass filter at the output of the demodulator may be changed to 200, 300 or 400 baud signal rate, by using the **FSKBaud** Parameters command.

The PTC-IIpro is therefore highly suitable, when used in the MODEM operational mode FSK as a demodulator for widely differing transmission methods. Packet-Radio with 300 Baud and multi-FSK systems such as PICCOLO etc. may be received when the appropriate PC program is available.

The NFSK-demodulator gives the measured frequency value to the RS-232 interface, at a baud rate set by the **MBaud** command. The center frequency is here also 1900 Hz. This frequency causes an output value of 128. A frequency range of  $\pm 500$  Hz gives an output

value of between 0 and 255. For frequencies outside this *measurement* range, the PTC-IIpro gives values of 0 or 255 whilst in FSK-MODEM operation.

Additionally, as in all FM modes, the data from the demodulator is available at PIN 6 of the RS-232 interface. It has passed a trigger stage, which results in a 1-bit digitized signal as output. If the PTC-IIpro measures an input frequency of greater than 1900 Hz, then PIN 6 goes to -10 Volts. For frequencies lower than 1900 Hz, the PTC-IIpro sets PIN 6 to +10 Volts.

As in other FM-MODEM operating modes, the tuning indicator indicates the output value directly.

For transmission using the NFSK-MODEM, refer to chapter 8.7.1, page 134.

### 8.6.7 Comparator

This MODEM command switches the PTC-IIpro into the COMPARATOR mode. The prefiltered receive signal, (filter bandwidth may be set with the **FResolut** parameter command), is limited and transferred to PIN 6 (DCD) of the RS-232 interface. The RS-232 port is, as in all other MODEM operations, still able to receive data. The COMPARATOR operations may be aborted when a byte value of 255 is received by the RS-232 interface. The baudrate is also during COMPARATOR operation set to the value given in the **Mbaud** command.

The PC-program used must be configured to simple modem such as **HAMCOMM** or **COMPARATOR**

The multitasking system of the PTC-IIpro is turned off during COMPARATOR operation due to the very high time resolution needed to form the limited square wave receive signal on the DCD PIN.

PR-operation using the integrated modules of the PTC-IIpro during COMPARATOR-MODEM operation is not possible!

### 8.6.8 PTC-IIpro with 300 baud HF Packet

This chapter describes a way to operate 300 baud HF Packet, but it is not the best and recommended way to do it. It is recommended to use the DSP Packet-Radio-Module-II to operate 300 baud HF Packet!

300 Baud Packet operation is possible with the PTC-IIpro when using the program **TFX** in addition. **TFX** is started on the PC as a TSR program (memory resident) and discretely operates the packet protocol in the background. The PTC-IIpro itself operates as a modulator/demodulator in this case, such as **BayCom** or **PC-COM**. The combination of PTC-IIpro and **TFX** emulates a *real* hostmode TNC for 300 baud Packet that can be operated with a hostmode terminal program such as **GP**. The command **PR300** starts the **TFX** compatible 300 baud PR modem.

Multitasking is disabled in this case, therefore no VHF/UHF Packet operation is possible the same time.

The LED's are set to medium brightness, i.e. the **BRightness** parameter has no function.

**TFX** should be used with *hardware DCD* turned on. The MARK tone is the one also valid for PACTOR and the SPACE tone is always located exactly 200 Hz below the MARK tone.

The **TFX** program is available at nearly every Packet-Radio mailbox or in the internet at <http://www.nordlink.org><sup>3</sup>

### 8.7 Transmission during MODEM operation

In every MODEM-operational mode, independent of if it is AM-FAX, FM-FAX, SSTV or FSK, the PTC-IIpro keys the transmitter (PTT becomes active) when it receives bytes with a value between 0 and 63. The transmitter stays on for exactly 166.7 ms after receiving each *transmit-byte*. If the PC program sends the transmit data appropriately fast, then the transmitter stays in the transmit condition. If the data does not change within the 166.7 ms (for example when in FM-FAX only *white* must be transmitted), then the PC program must send data to the PTC-IIpro at least every 166.7 ms, so that the transmitter stays on transmit. By using this system, an extra PTT-command is not required.

The maximum transmit amplitude is set using the **FSKAmp1** in the main menu. It is not necessary for any new setting to be undertaken, and can be left at setting for PACTOR or RTTY.

The PTC-IIpro displays the present transmit data on the tuning indicator directly. The *left-hand limit* represents the value 0, the *right-hand limit* 63.

During the transmit operation, the appropriate demodulator operates unchanged (up to the LED-display). The PTC-IIpro always operates in the special modes as a FULL-DUPLEX MODEM.

#### 8.7.1 Transmission in AM-FAX-Modem mode

For transmit operation in AM-FAX a constant carrier tone of 2400 Hz is generated. The transmit data controls the amplitude of this tone: The value 0 means the carrier tone disappears. The value 63 causes the maximum amplitude to be generated (that set by the **FSKAmp1** command). The transmit data controls the signal processor directly and without delays. The transmit signal bandwidth is also not limited through any hardware filter.

#### 8.7.2 Transmission in FM-FAX/FSK/SSTV-Modem mode

For transmit operation in all FM variants, a constant amplitude signal is generated (that set by the **FSKAmp1** command), the frequency of which relates to the transmit data amplitude. The transmitted data controls the instantaneous frequency of the output signal.

---

<sup>3</sup> Be aware that Internet addresses frequently change

For the value 0, the PTC-IIpro generates a frequency of 1500 Hz. The value 63 produces a frequency of 2300 Hz. Values between these limits produce the appropriate frequencies between 1500 and 2300 Hz. The frequency modulator in the DSP operates phase-continuous, and therefore produces a very clean and spectrally narrow signal. An output bandpass filter has thus been omitted.

The steepness of the frequency modulator is independent of the **Deviation** parameter, or other settings. The maximum possible shift of the transmitted FSK signal however is thus limited to 800 Hz.

In order to generate the synchronization signal below 1500 Hz, the PTC-IIpro must *understand* (as stated in the JV FAX-standard) three further bytes outside the 0-63 as transmit-data:

125 (dec.) generates the frequency 1100 Hz.

126 (dec.) generates the frequency 1200 Hz.

127 (dec.) generates the frequency 1300 Hz.

The Phasing-LED lights red during transmission of a synchronization tone.

### 8.7.3 Transmission in COMPARATOR mode

The transmission using the COMPARATOR MODEM is controlled with the **TXcomp** parameter (please refer chapter 8.8.11, page 139). If **TXcomp** is switched on, the handshake line CTS is used to control the PTT line, and the RxD PIN of the port supplies the transmission data. This method provides a very clear transmission signal, but has to be supported by a corresponding PC program.

If **TXcomp** is switched off, the PTT control via the CTS line is ignored. The transmission is completely handled by the PC program. As modulation signal, the audio signal of the *PC speaker* is used. However, this method is usually not recommended and hardly needs to be used.

## 8.8 The Parameter commands in detail

### 8.8.1 AGain

**Default setting: 50**

Parameter: X 1... 200, amplification factor for AM-FAX.

Sets the internal amplification factor for AM-FAX reception. The brilliance of the received picture can thus be set, without having to change the receiver volume. Some receivers offer an AF-output with a virtually constant amplitude. In this case, **AGain** offers almost the only possibility to adjust the brilliance of the received picture. With the **AGain** default value of 50, an input signal of 500 mV causes the maximum output value of 255 at the RS-232 interface. The **AGain** -Parameter operates as a linear amplification factor.

### 8.8.2 AResolut

**Default setting: 2**

Parameter: 0 1680 Pixel/sec.  
            1 2500 Pixel/sec.  
            2 3400 Pixel/sec.

Gives the maximum possible time resolution of the received signal in AM-FAX. Also the **AResolut** parameter adjusts the bandwidth of the input bandpass-filter appropriately. With noisy signals, it is recommended that the **AResolut** parameter is set to 0, as the effective signal to noise ratio is thereby increased. The maximum resolution is as follows: 0=1680 pixels/sec., 1=2500 pixels/sec, 2=3400 pixels/sec.

### 8.8.3 FResolut

**Default setting: 2**

Parameter: 0 1000 Pixel/sec.  
            1 1500 Pixel/sec.  
            2 2000 Pixel/sec.  
            3 2800 Pixel/sec.

Gives the maximum possible time resolution of the received signal in FM-FAX. Also the **FResolut** parameter adjusts the bandwidth of the input bandpass-filter appropriately. With noisy signals, it is recommended that the **FResolut** parameter is set to 0, as the effective signal to noise ratio is thereby increased. The maximum resolution is as follows: 0=1000 pixels/sec., 1=1500 pixels/sec, 2=2000 pixels/sec, 3=2800 pixels/sec.

### 8.8.4 SResolut

**Default setting: 2**

Parameter: 0 1000 Pixel/sec.  
            1 1500 Pixel/sec.  
            2 2000 Pixel/sec.  
            3 2800 Pixel/sec.

Gives the maximum possible time resolution of the received signal in SSTV. Also the **SResolut** parameter adjusts the bandwidth of the input bandpass-filter appropriately. With noisy signals, it is recommended that the **SResolut** parameter is set to 0, as the effective signal to noise ratio is thereby increased. The maximum resolution is as follows: 0=1000 pixels/sec., 1=1500 pixels/sec, 2=2000 pixels/sec, 3=2800 pixels/sec.

### 8.8.5 FSKBaud

**Default setting: 3**

Parameter: 2 200 Baud.  
3 300 Baud.  
4 400 Baud.

Gives the maximum possible baud rate that the NFSK-demodulator can process without inter-symbol interference (ISI, signal-smearing). With noisy signals, it is recommended that the **FSKBaud** parameter is set to 2, provided the received signal has a baud rate of 200 or less, as the effective signal to noise ratio is thereby increased. Baud rate-settings: 2=200 Bd, 3=300 Bd, 4=400 Bd.

### 8.8.6 Deviation

**Default setting: 400**

Parameter: X 100... 1000, shift of the FM-FAX demodulator in Hz.

Sets the steepness (shift) of the FM-FAX demodulator. (NOTE: in JVFX-mode, the shift can be changed using special control bytes independently of the **Deviation**-Parameter settings.) A **Deviation** value of 400 means that the demodulator will process a frequency range from 1500 Hz to 2300 Hz, i.e. frequencies from 1900-400 Hz to 1900+400 Hz.

### 8.8.7 MBaud

**Default setting: 57600**

Parameter: X 1200... 115200, baudrate during modem operation.

Sets the baud rate used by the serial interface during MODEM operation, i.e. whilst a FAX, SSTV or FSK-Modem is active. For the optimum display of high resolution FAX pictures, it is recommended that the rate is set to at least 57600, as long as the PC-program in use will support that speed. Additionally, if at all possible, the baudrate should be a multiple of 19200, in order that the SSTV synchronization processing works correctly.

### 8.8.8 HSynch

**Default setting: 50**

Parameter: X 10... 100, position of the sync pulse.

Sets the effective point in time where a recognized SSTV synchronization pulse, as such, is inserted into the received data-stream. Small corrections to the positioning of the picture edges can be made here by shifting the entire picture right or left. Normally, no changes in the **HSynch** default setting is required.

### 8.8.9 JSynch

#### Default setting: 1

Parameter: 0 LSB-SSTV-Synch disabled.  
          1 LSB-SSTV-Synch enabled.

Activates (1) or de-activates (0) the LSB-SSTV synchronization mode for SSTV. In this mode, the PTC-IIpro processes the SSTV synch-pulses separately, and re-introduces them, according to the JVFAX convention, into the two lowest bits of each of the data-bytes given out to the RS-232 interface. If there is no synch-pulse present, then the two lowest bits (0 and 1) are set to 1. The PTC-IIpro erases the two lower bits for the period of a synch-pulse.

### 8.8.10 SMode

#### Default setting: 1

Parameter: X 0... 15, SSTV sub mode.

Sets the SSTV sub-mode required. The **SMode** parameter is only used for the SSTV line-synch processing, as it is only here that specific information about the various SSTV sub-modes is required. If one wishes to work with any sort of SSTV signal, that is not in the following list, then the **SMode** parameter must be set to 0.

This has the effect that multiple-line checking of the synch processing is turned off. The PTC-IIpro works perfectly satisfactory in this mode, but weak signals naturally lead sometimes to a loss of synch with the normal synch pulse processing, with it's resultant picture distortion.

The multiple synch-check (**SMode** parameter not equal to 0) will only work without problem when the Modem baud rate (set via the **MBaud** parameter) a multiple of 19200, i.e. 19200, 38400, 57600, 76800 or 115200 Baud.

The PTC-IIpro shows the SSTV-submode with a 2 character long abbreviation of the first 2 characters of the green matrix display.

The following SSTV-modes are supported by the PTC-IIpro:

SMode	MODE-Name	Abbr. in display
0	ALLMODE	--
1	MARTIN 1	M1
2	MARTIN 2	M2
3	SCOTTIE 1	S1
4	SCOTTIE 2	S2
5	SCOTTIE DX	SD
6	8 sec / 120 line	08
7	16 sec / 120 line	16
8	32 sec / 240 line	32
9	WRAASE 24/128	W1
10	WRAASE 48/128	W2
11	WRAASE 48/256	W3
12	WRAASE 96/256	W4
13	WRAASE 120/256	W5
14	WRAASE 180/256	W6
15	ROBOT 72/256	R1

Table 8.2: STTV sub modes

### 8.8.11 TXcomp

**Default setting: 0**

Parameter: 0 COMPARATOR Tx disabled.  
1 COMPARATOR Tx enabled.

This PARAMETER-command activates (1) or de-activates (0) the TXD-modulator in the COMPARATOR mode. With **TXcomp** switched on, it is possible for many programs that support the HAMCOMM-modem to send FAX and SSTV direct from the PTC-IIpro. The PTC-IIpro looks at the voltage appearing on the CTS-line (PIN 7 of the RS-232 interface). When +10 volts appears, the PTT line for the shortwave port is activated. The PTT line is de-activated (turned off) when the voltage is -10 V. When in the send condition, the PTC-IIpro measures the incoming data as square wave modulation data on the RxD PIN.

The zero crossing point is measured very exactly, and then modulates the *VCO* in the DSP. The PTC-IIpro has a very good transmit resolution even in the *Simple Modem* mode, providing the PC program works as precisely. The translation of the transmit-data into a *clean* analogue signal is not just through an RC low pass filter (as is usual). Instead, the system calculates exactly the reverse of the simple demodulator principle.

## 8.9 LED functions and matrix-display

### 8.9.1 The LED's whilst receiving

When the **Jsynch** parameter is turned on, the Phasing-LED (red) shows a line-synch pulse by blinking. The Connected-LED (yellow) blinks when a vertical (frame) synch-pulse is received during SSTV operation.

### 8.9.2 The LED's whilst transmitting

The Phasing-LED displays tones between 1100 and 1300 Hz.

The tuning indicator displays directly in every mode the output value (0-255) or input (whilst transmitting) value (0-63). The *left-hand limit* represents value zero, the *right-hand limit*, the maximum value.

During transmit, the modulator has priority with respect to the LED control. The tuning indicator displays the transmitted data condition, although the PTC-IIpro, operating as a FULL-DUPLEX MODEM, continues to produce receive data.

### 8.9.3 Information in the Matrix Display

If a branch is made to the FAX sub-menu, then **FAX MENU** is displayed.

In each MODEM condition, the center of the display shows the Modem mode, e.g. **AM-FAX**, **FSK**, **SSTV** etc.

If the actual MODEM is chosen from the JVFX-MODE by use of a control-byte (refer to chapter 8.6.4, page 131), the first two characters of the display show the letters **JV**. Otherwise -- is displayed.

During SSTV operation, the last two characters show an abbreviated form of the chosen SSTV sub-mode (refer to **SMode** parameter command, chapter 8.8.10, page 138).

The NFSK-MODEM shows the last three characters of the maximum baud rate limit of the demodulator (refer to **FSKBaud** parameter command, chapter 8.8.5, page 136).

### 8.9.4 Tuning- and LED display in COMPARATOR mode

The tuning indicator covers the range  $1900 \pm 800$  Hz in both transmit and receive operation. In addition, during transmit, the Send-LED on the PTC-IIpro lights green. The green alphanumeric display shows **COMPARATOR** during COMPARATOR operation.

The LED's are always switched to middle brightness during COMPARATOR operation, again due to the computer time needed. The **BRightn** parameter has no thus effect during the time the PTC-IIpro is switched to COMPARATOR.

### 8.9.5 LED's in PR300 operation

The following LED's are in use: Tuning-display, Send-LED (green) for PTT, Phasing-LED (red) for DCD (digital carrier detect).

## 8.10 Tips and Tricks

### 8.10.1 IF-SHIFT

With the normal SSB speech reception, the speech frequencies stretch from 300 to 2700 Hz. Steep sided SSB filters usually have a 6 dB bandwidth of around 2.4 kHz. The FM-FAX standard sets a center frequency of 1900 Hz. With standard resolution FAX and SSTV pictures, the signal requires a bandwidth of approximately 2.5 kHz. The audio limit frequencies that should be transmitted are 1900-1250 Hz and 1900+1250 Hz or 750 Hz and 3150 Hz. The frequency band for FAX/SSTV appears to be shifted about 400 to 500 Hz higher in frequency. With normal SSB reception, the higher FAX/SSTV tones suffer great attenuation and thereby cause asymmetrical reception.

In order to help this situation, it is recommended that the IF-SHIFT control be used. With the TS-450 for example, it has been found that the best setting is around *3 o'clock*. The ideal setting is that at which the tuning indicator flickers symmetrically around the middle point when only noise is present on the receive channel.

### 8.10.2 Tuning with SSTV

The FAX/SSTV tuning indicator is (by its very nature) a somewhat *diffused* and in-exact indicator. It has been shown, that tuning for a *clean* and rhythmical blinking of the Phasing-LED at line frequency, is a good way of tuning in SSTV signals. The **JSynch** parameter must naturally be set to 1.



## Chapter 9

### 9 Packet-Radio

The Packet-Radio-menu (**pac:-menu**) is activated with the command **PACket**. The command prompt takes the form **pac:** .

The following commands are available in the **pac:-menu**:

**Aprs, Baud, CBell, CCheck, CMsg, Connect, CText, DIGIpeat, Disconnect, FRack, FSKFilter, FULLdup, Help, Jhost1, MAXframe, MCon, MFilter, Monitor, MStamp, MText, MYAlias, MYcall, MYMail, PACLen, PERSist, Port, PRBox, Quit, RESptime, RETry, Setchn, SLOttime, TRACE, TXdelay, TXLevel, Unproto, USers.**

All other (*normal*) commands are not available in the **pac:-menu**! **Quit** or **DD** exit the **pac:-menu**.

The **PACket** command can be followed by a valid **pac:-command** as an argument. As with the other sub functions of the PTC-IIpro, it is also possible to pass through direct commands.

Switch off the Packet-Radio listen – without using the **pac:-menu**

**cmd: PAC M 0 <Return>**

Packet-Radio with the PTC-IIpro will only function in conjunction with the optionally available Packet-Radio modules from **SCS!**

#### 9.1 DAMA

The PTC-IIpro in Packet-Radio is full compatible with the ☞DAMA (Demand Assigned Multiple Access) standard. You easily recognize a DAMA-Digi with a look to your monitor. The expression [DAMA] is added to the header of the monitored packets, if the packet is received by a DAMA-Digi. The DAMA mode needs not be activated by the user. The PTC-IIpro automatically notices if you are working with a DAMA-Digi or not and behaves respectively.

#### 9.2 Packet-Radio-modules

- DSP module: for 300 and 1200 Baud AFSK as well as 9600 and 19200 Baud FSK (G3RUH compatible).

All modules contain all necessary electronics for signal processing, modulation and demodulation. The actual packet protocol processing is done by the PTC-IIpro firmware.

##### 9.2.1 The SCS-DSP-Module-II

The DSP-Packet-Radio module has been developed for Packet-Radio operation with the PTC-IIpro. The module only has to be inserted into one of the internal sockets of the

PTC-IIpro, everything else is done by the PTC-IIpro automatically. The two sockets are equal, it does not care where you insert the module at first.

The PTC-IIpro automatically recognizes the DSP-PR-module directly after power-on and loads the DSP software into the module, which is a part of the PTC-IIpro firmware it can be improved and expanded via firmware updates.

The DSP concept for PR also allows the software setting and adjustment of all modem parameters (for example the audio output level). The adjustment of a potentiometer is not necessary.

The DSP-PR modem offers the following modes:

- 200 and 600 baud Robust HF-Packet
- 300 Bd AFSK (Modem tones are fixed at 2300/2100 Hz, "High-Tones")
- 1200 Bd AFSK
- 9600 Bd FSK (Direct-FSK according to the G3RUH standard)
- 19200 Bd FSK (Direct-FSK according to the G3RUH standard)

The choice takes place with help of the **Baud** command in the **pac:-**menu or the **%B** command in hostmode. Both commands are port-sensitive.

The choice or setting of the correct modulation for the actual baudrate is automatically made by the PTC-IIpro. The DSP PR modem is capable of full duplex in all modes.

With direct FSK according to G3RUH, mixed Baudrates for TX and RX are allowed, e.g. 9600 Baud for receive and 19200 Baud for transmission. Certainly, the DSP PR modem contains a high performance Data-Carrier-Detection (DCD) in all modes.

### 9.2.1.1 Robust HF-Packet

Robust HF Packet can only be operated with the DSP-Packet-Module-II installed!

For the selection and configuration of the robust modulation for HF-PR no special commands are necessary. The selection of the modulations type follows the usual way with the **Baud** command in the **pac:** menu or **%B** command in hostmode. The transmit level is taken from the **PSKAmp1** (PACTOR PSK-amplitude, refer to chapter 6.74 on page 97 and chapter 3.3.4 on page 17).

The center frequency of the audio signal is fixed to 1500 Hz. On the receive side the same side band as the transmit side must be used. We generally recommend USB.

With "Robust PR"-modulation selected the PTC assumes that a connection will be via a HF Channel and adjusts a few parameters automatically.

MAXFrame is automatically administrated;  
the value given by the user does not matter.

RETriEs is automatically doubled.

TXDelay is automatically divided by 4.  
The default setting 100 results in the usual 25 msec for Shortwave.

RESptime is automatically halved.

Following additional Parameters of the **Baud** command are available:

Baud R300: During an X.25 connection automatic / self adaptive selection between 200 bit/sec and 600 bit/sec. UI-Packets (e.g. APRS) are transmitted in 200 bit/sec.

Baud R600: During an X.25 connection automatic / self adaptive selection between 200 bit/sec and 600 bit/sec. UI-Packets (e.g. APRS) are transmitted in 600 bit/sec.

The arguments valid for **Baud** are also available in the same form for the Hostmode command **%B**.

As the Robust-PR demodulator automatically detects which modulation is received, e.g. an APRS network can successively grow or be adapted to the actual requirements: If only a few users are present but the distances are large then the longer but more robust modulated packets can be used. In the opposite case, when many participants are present but the average distances are smaller, then the faster/shorter packets can be used.

### 9.2.1.2 Specialities of 300 Bd AFSK

300 Bd AFSK is normally used via an SSB transceiver, and usually requires a tuning tolerance of  $\pm 30$  Hz for satisfactory performance. The DSP modem thus requires a tuning indicator for this mode. As the PTC-IIpro only has three LEDs for each port (PTT, Connected, Carrier), a two dimensional tuning display cannot be realised. Instead, the tuning takes place by using the brightness of ONE LED. With a bit of practice, one can obtain a tuning tolerance of  $\pm 10$  Hz using this method.

The fine adjustment of a received signal takes place with the help of the brightness of the PTT LED. Maximum brightness corresponding to the best tuning. The tuning display via the PTT-LED is ONLY active when a signal is recognised (i.e. initial tuning by ear until the "carrier" LED lights). If ONLY the PTT-LED lights, then the transmitter is keyed momentarily. The PTT LEDs then have their normal function. Note: The "carrier" LED never lights whilst transmitting in full duplex operation, even when a signal is received.

In practice, the tuning takes place by slowly turning the tuning knob until the carrier LED lights. With an active carrier LED, further careful tuning backward and forward is made until the PTT LED is at its maximum brightness. The PR monitor can also be turned on as a further tuning help, to see if valid data packets are being received.

### 9.2.2 Additional-Modules

Together with the DSP-PR-module 2 other modules were in production until the beginning of 2001. They are discontinued now but they can be used with the PTC-IIpro as well.

- AFSK module: for 1200 and 2400 Baud AFSK with a standard modem chip TCM3105 and a completely digital carrier detection.
- FSK module: for the G3RUH compatible FSK method (9600 Baud etc).

The PTC-IIpro automatically recognizes the modules when inserted and reacts respectively. The modules only have to be inserted into the internal sockets of the PTC-II, everything else is done from the PTC-II automatically. Only the output level of the module has to be adjusted manually dependent on transceiver being used. The other settings are done comfortably by software command.

### 9.3 External modems

The PTC-IIpro also supports *foreign* modems. It is possible to connect modems for satellite operation or special modulation systems to the PTC-IIpro. The connectors normally used for connecting the **SCS** modems serve as *Modem disconnect* in this case.

The connections of pins 1 to 20 conform exactly to the recommendation for high speed modems by DF9IC from the ADACOM-magazine no 2. The pins 21 to 26 are an extension especially used for the PTC-IIpro and must remain unconnected.

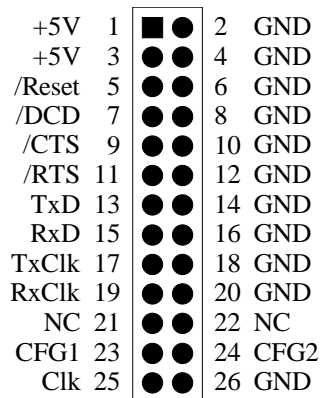

Figure 9.1: Pin connections for the modem connector

PIN	SIGNAL	FUNCTION
1	+5 Volt	Power supply to modem from the PTC-IIpro
3	+5 Volt	Power supply to modem from the PTC-IIpro
5	/Reset	PTC-IIpro reset line
7	/DCD	Carrier recognition (from modem to PTC-IIpro)
9	/CTS	Transmitter is keyed (from modem to PTC-IIpro)
11	/PTT	Key transmitter (from PTC-IIpro to modem)
13	TxD	Transmitter data (from PTC-IIpro to modem), NRZI coded!
15	RxD	Received data (from modem to PTC-IIpro), NRZI coded!
17	TxC	Transmitter clock (from modem to PTC-IIpro)
19	RxC	Receiver clock (from modem to PTC-IIpro)

Table 9.1: The modem signals and their function

The signals with a / before them are active low.

The even numbered PINs from 2 to 20 are connected to ground. This enables good shielding and ground conditions to be obtained, even against cross talk within the cable.

The name and function of the connection is only valid for external modems. For the usage with **SCS** Packet-Radio modules the connections are totally new programmed and have another function.  
 The PINs from 21 to 26 are reserved for **SCS** Packet-Radio modules and must remain unconnected at external modem use!

The modem can be supplied with power via the two 5 volt pins. The current drawn should not exceed 150 mA.

The transmit and receive data (TxD / RxD) are processed by the PTC-IIpro as an NRZI coded signal. The NRZ-NRZI converter contained in many other modems is not required. In the original DF9IC modem, the NRZ-NRZI converter is programmed in the GALs. Here, the GAL-FSKR and GAL-FSKT must be replaced with the appropriate NRZI-GAL.

The pins 21 to 26 are PTC-IIpro specific extensions, and must remain unused when an external modem is connected!

The internal Packet-Radio ports of the PTC-IIpro are not especially protected. Take care for the restrictions working with CMOS components.

The easiest way to connect of external modems is using flat-band cable and an appropriate connector with the well known crimp fittings. For a modem a 26 PIN in-line header socket plus another 20 PIN in-line header socket and a 20 way flat-band-cable is required. The in-line header sockets are crimped to the cable according to the following [Figure 9.2](#):

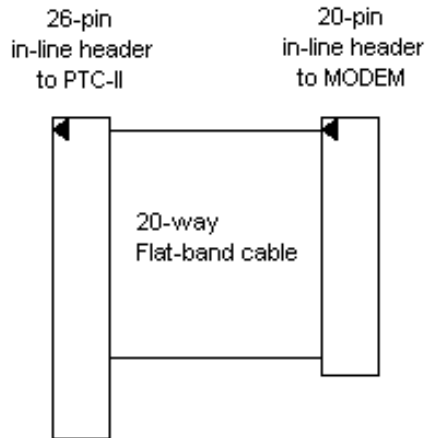

Figure 9.2: Flatband cable PTC-IIpro - MODEM

The length of the flat-band-cable is not critical. If however, the cable is extended to outside the PTC-IIpro case, then the radiation of interference from it may be quite high.

The figure below shows the location of the connectors and their pin 1.

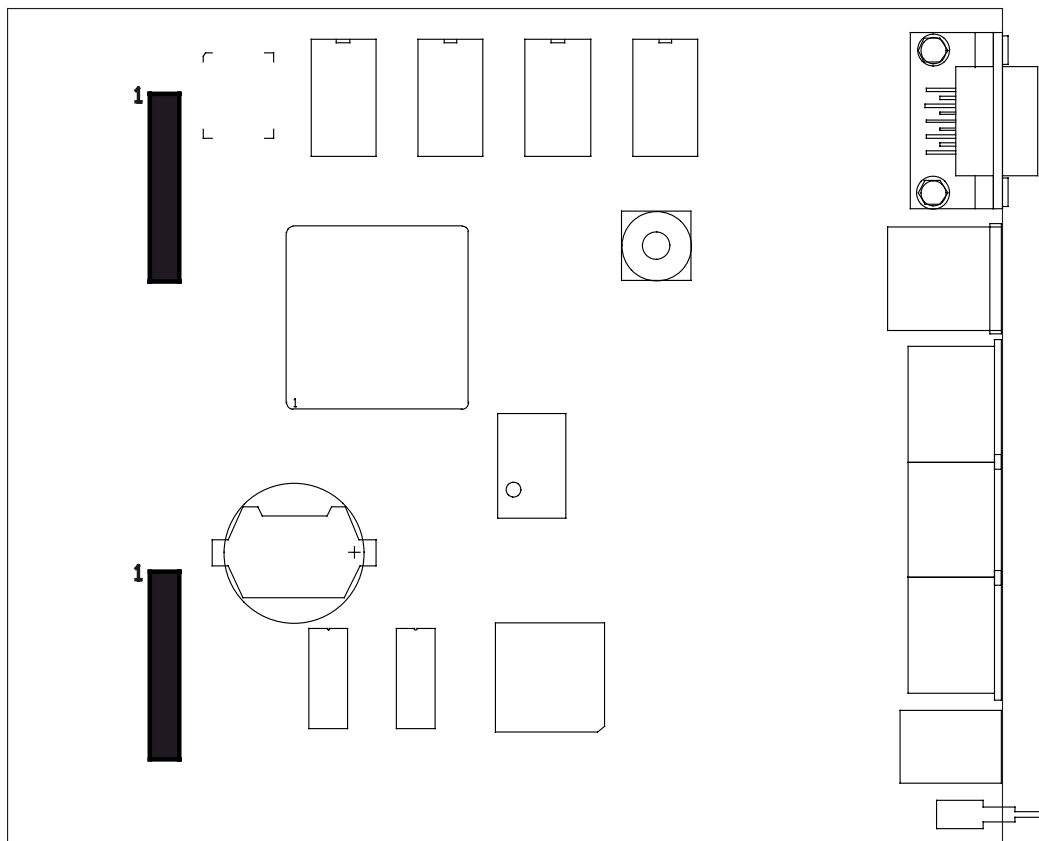

Figure 9.3: Position of the Packet modem connectors

## 9.4 Port & Channel

The terms **Channel** and **Port** are very important for understanding the functions of the Packet-Radio options in the PTC-IIpro, and the difference must be clearly understood.

**Port:** A port describes the hardware that is required to transmit and receive the information. To use a port, a modem (PR-module) must be installed, and the radio then connected to it. The PTC-IIpro contains two possible ports, which correspond to the two available sockets on the main board.

**Channel:** An AX.25 QSO may be found on a channel, the number of channels setting the number of simultaneous links which can be made to other stations.

The term *Multiport* describes commands that work separately for each port. It is, for example, quite possible that a different **TXdelay** may be required on each port. The port input for the multiport commands is set directly before the parameter, separated with a colon (:), as in:

Command Port:Parameter

No spaces are allowed between the port input, the colon, and the parameter!

As an example, the **TXdelay** command is being used:

Checking the **TXdelay** on port 1:

**pac: TX 1:** <Return>

Checking the **TXDelay** on port 2:

**pac: TX 2:** <Return>

Set the **TXdelay** on port 1 to 200 ms:

**pac: TX 1:200** <Return>

Set the **TXdelay** on port 2 to 90 ms:

**pac: TX 2:90** <Return>

The PTC-IIpro expects all time parameters in milliseconds!

If one works mainly on one particular port, after a while it becomes a bit of a chore always having to give the port number, so it has been made possible to define a standard port with the **Port** command, on which the multiport commands work when port input is omitted, for example, the following command sets the standard port to port 2:

**pac: Port 2** <Return>

Now all multiport commands without a special port number are valid for port 2.

Checking the **TXdelay** (on port 2):

**pac: TX** <Return>

Set the **TXdelay** to 150ms (on port 2):

**pac: TX 150** <Return>

## 9.5 Modern Times

We hope you have already recognized the following warning:

The PTC-IIpro expects all time parameters in milliseconds!

The settings of the time parameters are very important for proper Packet-radio operation! How long to wait for the confirmation (**FRack**). How long is the time until it is checked if the other station is still available (**CHeck**), etc. The function and most of all the reliability of a Packet-Radio connection depends on the time parameters.

Because of this, check the initialization files of programs you use in advance and very carefully. Often the added examples are designed for a TNC 2. But the TNC 2 expects the time inputs in 10 ms steps, e.g. for a `TxDelay` of 100 ms the value 10 has to be given for a TNC 2! But the PTC-IIpro needs the value in milliseconds, that means 100.

If you use the initialization files without checking, it could happen, that the very important timing data becomes 10 times too low.

The *most frequently* done mistakes according to wrong times are:

- At connect establishment all attempts of the PTC-IIpro are transmitted in very short distances.
- On a DAMA-Digi it could happen that suddenly the connection hangs. Digi and PTC-IIpro exchange RR frames only.

Please search for the following commands, **CHeck**, **FRack**, **RESptime**, **SLOttime** and **TXdelay**, in the initialization file of your program and check the settings. In any case you have to adjust the TX delay (**TXdelay**) due to your needs. It is possible to delete all other commands within the initialization file or take the default settings.

## 9.6 Commands

### 9.6.1 Aprs

Multiport

**Default setting: 0**

Parameter: 0 Off, APRS-beacon disabled  
1 On, APRS-beacon transmits GPS-position data if available  
2 FIX, APRS-beacon transmits fixed position data (adjustable with **Aprs Position**).

In GPS mode the beacon only sends if the position data is not older than 20 minutes. If the GPS receiver fails, the beacon terminates the transmission after 20 minutes.

The APRS beacon uses as sender call-sign the **MYcall** of the virtual channel 0. As long as this call-sign is not set the APRS-beacon cannot be activated. The **MYcall** of the virtual channel 0 is automatically set to the Pactor **MYcall** (after a **REStart**), so that normally only a single **MYcall** entry is necessary to set all PACTOR as well as Packet-Radio/APRS **MYcall** to your own call-sign..

Additional to the normal numeric parameters, the **APRS** command provides several sub commands:

**COmment, PAth, POsition, SHort, SYmbol, TImeR**

Also refer to chapter [5.9](#) on page [50](#).

### 9.6.1.1 APRS COmment

**Default setting: none**

Parameter: - or at maximum 40 characters

Sets the comment text that is added to every APRS-datagram. E.g. a short description of the system can be entered: "PTC-IIpro 20 W, Dipole". The comments maximum length is 40 characters. Longer comments will be rejected with an error message. A minus character (-) as first Comment character sets the Comment to "NONE", and with this deletes the comment.

APRS comment should be as short as possible as the APRS-datagram will be longer (sometimes much longer), which can lead to a (unnecessary) high channel occupation.

### 9.6.1.2 APRS PAth

**Default setting: APRS via RELAY WIDE**

Parameter: APRS target call and at max. 8 digipeater calls

Defines the AX.25 transmit path including target callsign and maximal 8 digitpeater callsigns, also with their respective SSID's if available. Examples:

**pac:** A PA CQ ia RELAY <Return>

**pac:** A PA APRS RELAY WIDE GATE<Return>

Between the target callsign and (optionally) the digitpeater list a "v" or "via" can be inserted to increase readability.

A description of the operation of current APRS digipeater callsigns exceeds the boundaries of this user manual. Appropriate information can be found in relevant literature e.g. Internet. In case no exact information of available digipeaters to hand, it is recommended to select the first digitpeater "RELAY"

### 9.6.1.3 APRS PPosition

**Default setting: NONE**

Parameter: XXXX.XXS/N YYYYY.YYW/E

Allows the entry of the position for the “FIX” operation (Aprs 2, see 9.6.1). The position must be entered exactly in the correct format for “Latitude Longitude”, which means degrees including leading zeroes, directly followed by minutes with 2 decimal places and including the direction. Any other format will be rejected with an error message.

Example:

```
pac: A PO 4810.30N 01030.25W <Return>
```

### 9.6.1.4 APRS SHort

**Default setting: 1**

0 Compression off

Parameter: 1 Compression on

Activates (1) or deactivates (0) the compression of the position data in the APRS datagram.

The compressed format has only advantages: Shorter datagrams, very accurate, speed and direction can be included in the transfer. However because some APRS programs cannot correctly interpret the compressed format, the **SCS** firmware allows the compression to be switched off. Also the uncompressed position data can be directly monitored as the usual “Latitude Longitude format” is sent in plain text.

### 9.6.1.5 APRS SYmbol

**Default setting: 15 [Dot]**

Parameter: 1...94, a1...a94

Sets the graphic APRS symbol that an APRS receiving station should display: e.g. a symbolic car in mobile service (Symbol 30). The symbol numbers follow exactly the table in the APRS protocol version 1.0. The complete protocol information is available on the Internet. Symbols from the alternative table (“alternate table”) can be selected by prefixing an “a” before the symbol number, e.g.: A SY a13 for “Home(HF)”.

If no symbol number is given as an argument the A SY command (normal way) displays the actual parameter settings, however with a current symbol additionally with a short description in square brackets. E.g.: a13 [Home (HF)].

Here is a selection of current symbols or their numbers:

- 6: HF Gateway
- 7: Small Aircraft
- 13: House QTH (VHF)
- a13: House (HF)
- 15: Dot
- 27: Campground
- 28: Motorcycle
- 30: Car
- 47: Balloon
- 50: Recreational Vehicle
- 53: Bus
- 56: Helicopter
- 57: Yacht (sail boat)
- 65: Ambulance
- 66: Bicycle
- 70: Fire Truck
- 74 Jeep
- 75: Truck
- 83: Ship (Power boat)
- 86: Van

### 9.6.1.6 APRS TImeR

**Default setting: 900**

Parameter: X 0, 1...7200

Sets the beacon interval in seconds. With the default setting 900, the beacon transmits every 15 minutes, if position data is available and the “global MYcall” is set on the virtual channel 0.

Parameter 0 activates the speed dependant automatic mode: The interval is then calculated by the formula: Interval [sec] = 1800/GPS speed (knots). With speeds above 180 knots the interval is limited to 10 seconds. With speeds below 1 knots the interval is limited to a maximum of 1800 seconds.

The automatic can only work properly when the speed is contained in the GPS datastream, which means that RMC data must be available from the connected GPS

receiver. If speed data is available the interval in automatic mode is set to 900 seconds. With “FIX”-Position (Aprs 2, see 9.6.1) and automatic timer, the firmware sets the interval independent of the speed data from the GPS receiver to 1800 seconds.

### 9.6.2 Baud

Multiport

**Default setting: 1200 or 9600**

Parameter: Rx Rx baud rate for the radio link.  
Tx Tx baud rate for the radio link.

Setting / checking the radio link baud rate.

Without a parameter, the **Baud** command shows the modem type, and the baud rate set.

If a valid baud rate is given as a parameter, then this is set in the Packet modem, valid baud rates are:

- For the **SCS** AFSK-Modem: 1200 and 2400.
- For the **SCS** FSK-Modem: 4800, 9600, 19200, 28800, 38400, 57600, 115200.
- For the **SCS** DSP-Modem-II: R300, R600, 300, 1200, 9600, 19200.

Some digipeater work with higher baudrate in direction to the user than at the *Upload* side, e.g. Digi →User 19k2 and User →Digi 9k6.

The **Baud** command accepts two arguments, e.g.

**pac: Baud 19200 9600 <Return>**

The first argument is the desired receiving baudrate, the second argument is the desired transmission baudrate.

If only one argument is given, the PTC-IIpro uses this value for both, TX baudrate and RX baudrate, e.g.

**pac: Baud 9600 <Return>**

It is also possible to enter the port directly, e.g.

**pac: Baud 2:19200 9600 <Return>**

The baudrate values for ports with the **SCS** DSP-Modem are stored in the Flash-ROM and remain valid also after a **REStart** or a firmware update.

### 9.6.3 CBell

**Default setting: ON**

Parameter: OFF Connect bell off.  
ON Connect bell on.

Turns the connect bell on, or off. If the connect bell is turned on, then every connect is signaled with an acoustic signal, and, additionally, the PTC-IIpro sends a bell character (<BEL>, ASCII 7) to the terminal.

### 9.6.4 CHeck

**Default setting: 300,000**

Parameter: X 0... 3,000,000, time in milliseconds.

The **CHeck** command sets the T3 or link activity timer. If nothing is heard from the partner station during the time T3, then the link status is queried.

### 9.6.5 CMsg

**Default setting: 1**

Parameter: 0 Switch connect text off.  
1 Switch connect text on.  
2 Switch connect text on and evaluation of special functions.

Enable or disable the connect text.

If **CMsg** is set to 2, the following sequences //B <CR> and //Q <CR> are accepted additionally. The two sequences are noticed if they occur at the beginning of a line and are closed directly with <CR> or <Return>.

//B initiates the sysop-bell (duration about 14 seconds). After receiving //Q the PTC initiates a disconnect.

The sysop-bell is set using the **BEll** command of the **cmd:-**menu. To disable this function (refer to chapter 6.11, page 66)

### 9.6.6 Connect

Multiport

**Default setting: none**

Parameter: <target-call> [<Digi1> <Digi2>.....]

**Connect** sets up the AX.25 link. The connect can take place over both ports in the PTC-IIpro, the required port being given directly before the target callsign:

DL1ZAM connect via Port 1:

**pac: C 1:DL1ZAM <Return>**

DL2FAK connect via Port 2

**pac: C 2:DL2FAK <Return>**

If no special port is given, then the PTC-IIpro uses the default port that has been set using the Port command. If the link takes place via one or more digipeaters, then the list of digipeaters should be given directly after the target callsign.

DL6MAA connect via DB0KFB

**pac:** C DL6MAA DB0KFB <Return>

### 9.6.7 CONStamp

**Default setting:** OFF

Parameter: OFF Time stamp off.  
ON Time stamp on.

Activates the display of time stamps on connect and disconnect messages.

### 9.6.8 CONVerse

Manually activates the converse mode. This function is seldom needed, as the PTC-IIpro automatically switches to the converse mode after a successful link up.

Alternatively a **K** may be used, as abbreviation for **CONVerse**.

The Converse-mode can be terminated with the entry of

<ESC> **CONVerse** <Return>

or

<ESC> **K** <Return>

### 9.6.9 CStatus

**CStatus** lists the condition of the channel, the link status.

### 9.6.10 CText

**Default setting:** >>> Welcome...

Parameter: String of 249 characters, maximum.

The Connect text is transmitted when **CMsg**=1 and the PTC receives a connect.

As the **CText** input uses the command interpreter, a special convention for the <CR>-character must be used. A <CR> is represented in the CTEXT string by a '#'.

```
>>> Welcome to %'s PTC-IIpro DSP/QUICC System <<<
To leave a MSG, please connect %-8 (PTC-Mailbox)!
```

The string above would be given as:

```
pac: CT >>> Welcome to % 's PTC-IIpro DSP/QUICC System <<<##  
To leave a MSG, please connect %-8 (PTC-Mailbox)!  
<Return>
```

The % character serves here as a dummy for the appropriate MYCALL of the connected channel. The SSID of the MYCALL is ignored. For example if DL1ZAM is the MYCALL, then the PTC-IIpro will give the following message to the connected PR station:

```
>>> Welcome to DL1ZAM's PTC-IIpro DSP/QUICC System <<<  
To leave a MSG, please connect DL1ZAM-8 (PTC-Mailbox)!
```

The Command interpreter buffer is 256 characters long. Commands plus CTEXT argument should not contain more characters, otherwise the CTEXT will be truncated.

### 9.6.11 DIGIpeat

**Default setting: OFF**

Parameter: OFF Digipeating disabled.  
ON Digipeating enabled.

Enable or disable digipeating using the own station.

### 9.6.12 Disconnect

Ends an AX.25 link. If there is still data to be sent to the partner station, then this data is transmitted first, before the disconnect is carried out.

If the **Disconnect** command is given twice, one after the other, then the link is broken immediately (corresponding to **DD** in PACTOR).

### 9.6.13 FRack

**Default setting: 5000**

Parameter: X 1... 15,000, time in milliseconds.

**FRack** sets the time in which a packet must be acknowledged. If the PTC-IIpro sends a packet, and no acknowledgment is forthcoming within the Frack time, then the PTC-IIpro queries if the information has arrived.

The here given value of **FRack** is just the start value. The used value is dynamicly recalculated during a connection using the formula:  $Frack = 2 * SRTT * X$ . Hereby  $X = RETRY$  if  $RETRY > 2$ , otherwise  $X = 1$ . SRTT is the "Smoothed Round Trip Time". X is generally 1 under link establishment condition.

### 9.6.14 FSKFilter

Multiport

**Default setting: 0**

Parameter: X 0... 15, Filter parameter for the **SCS** FSK modem..

This command is only valid in connection with **SCS** FSK modem!

The filter parameters provide a certain adaptation of the signal to the frequency transfer characteristics of the transceiver. In most cases, good results are already obtained using the default setting 0. If any problems occur when connecting a certain digipeater, another value should be tried.

The filter parameter operate in the transmission mode only !

### 9.6.15 Fulldup

Multiport

**Default setting: OFF**

Parameter: OFF Full duplex disabled.  
ON Full duplex enabled.

Switches the port into full duplex operation, which allows the simultaneous transmission and reception of data at a port.

Switches the full duplex on port 1 off:

**pac: Fulldup 1: 0** <Return>

Switches the full duplex on port 2 on:

**pac: Fulldup 2: 1** <Return>

Switches full duplex on the present port (default port) off.

**pac: Fulldup 0** <Return>

### 9.6.16 Help

Lists all the Packet-Radio commands.

### 9.6.17 JHOST

**Default setting: 0**

Parameter: 0 Exits the hostmode.  
1 Starts the hostmode.  
4 Starts the CRC hostmode.

Switching to the hostmode.

The command is used by the hostmode software to switch to the hostmode. During *normal* operation within the terminal mode this command has no function.

For furthermore information about the PTC-IIpro hostmode refer to chapter 10, page 167.

It is strictly forbidden to enter the **JHOST** command in the initialization file of the hostmode programs! hostmode programs switch to the hostmode independently.

### 9.6.18 MAXframe

Multiport

**Default setting: 7**

Parameter: X 1... 7, number of unacknowledged packets.

Maximum number of unacknowledged info packets (I Frames) in a link, i.e. **MAXframe** defines the number of packets the PTC-IIpro transmits continuously. The value should be reduced in case of bad links.

### 9.6.19 MCon

**Default setting: 0**

Parameter: X 0... 6, frame type.

**MCon** sets whether the monitor should remain switched on in terminal mode, even during a connect. Values greater than 0 switch on the monitor. Values greater than 1 set the type of frames that are displayed:

- 0 - Monitor switched off.
- 1 - Only UI-Frames
- 2 - Additionally I-Frames
- 3 - Additionally SABM- and DISC-Frames.
- 4 - Additionally UA- or DM-Frames
- 5 - Additionally RNR, RJ and FRMR
- 6 - Additionally Poll/Final Bit, PID and serial numbers

### 9.6.20 MFilter

**Default setting: 10**

Parameter: X 1... 128, max. 4 ASCII characters.

This command removes the given characters from the data stream (maximum 4 arguments). The arguments must be given in decimal or hexadecimal (prefixed with a \$ character) ASCII values.

**Only** works in PR-terminal-mode, and can only be accessed in that mode. (Does **not** operate in hostmode!)

Filters received and transmit characters. The default value is 10, i.e. Linefeed. This has the effect that <CR>/<LF> in PR-Terminal-mode no longer causes incompatibility with **DieBox** mailbox systems.

If the character is set to ASCII 128, then a special filter is activated, which filters out all CONTROL characters (range 0-31) except <CR>, <LF> and <TAB>.

Set filter for <LF> and <BELL>

**pac: MF** 10 <Return>.

### 9.6.21 Monitor

**Default setting: 0**

Parameter: X 0... 6, frame type.

Switch monitor on and off.

Values greater than 0 switch the monitor on, and values greater than 1 set which frame types will be monitored.

0 - Monitor switched off.

1 - Only UI-Frames

2 - Additionally I-Frames

3 - Additionally SABM- and DISC-Frames.

4 - Additionally UA- or DM-Frames

5 - Additionally RNR, RJ and FRMR

6 - Additionally Poll/Final Bit, PID and serial numbers

### 9.6.22 MStamp

**Default setting: OFF**

Parameter: OFF Time stamp off.  
ON Time stamp on.

**Mstamp** activates the time stamp for packets that are displayed via the monitor.

### 9.6.23 MText

**Default setting: '>>> Welcome...'**

Parameter: String of 249 characters, maximum.

Identical to the **CText**-command in the **pac**-menu, however sets the connect-text for the PR-mailbox.

The default text is as follows:

```
>>> Welcome to %'s PTC-IIpro Mailbox <<<
      Please type H for help.
```

The **MText** input is done via the normal command interpreter, so a convention for the <CR> character has to be used: The <CR> is represented within the **MText** string by #.

This would be input like:

```
pac: MT >>> Welcome to %'s PTC-IIpro Mailbox <<<## Please type H for help.
<Return>
```

The same as in **CText**, the % character serves here as a dummy for the appropriate MYCALL, independent if it is a BBS callsign or the normal MYCALL. The SSID of the MYCALL is ignored.

For example if DL1ZAM-8 is the BBS-MYCALL, then the PTC-IIpro will give the following message:

```
>>> Welcome to DL1ZAM's PTC-IIpro Mailbox <<<
Please type H for help.
```

The **MText** always follows the message from the automatic *mail notifier*, i.e. "\*\*\* NO new MSG for you" or "\*\*\* 2 new MSGs for you" or similar.

The **MText** cannot be turned off.

### 9.6.24 MYAlias

**Default setting: SCSPTC**

Parameter: CALL Alternative station callsign.

**MYAlias** is handled as **MYcall** for incoming connects, and can also be used as an alternative station callsign. If the PTC-IIpro is called by the **MYAlias** callsign as a digipeater, he works as a cross port digipeater, i.e., packets received at port 1 are send out at port 2 and vice versa. The kind of modem at the relevant port is not important, because of this cross digipeating from 1200 baud to 9600 baud and vice versa is possible.

The default of the **MYAlias** callsign is the PACTOR MYCALL entered first of all., but gets the SSID 15. If for example the global MYCALL on the PACTOR is set to DL6MAA, the PTC-IIpro sets the MYAlias to DL6MAA-15. This default setting can be changed at any time using the **MYAlias** command of the **pac**-menu.

### 9.6.25 MYcall

**Default setting: SCSPTC**

Parameter: CALL Callsign of the PTC.

Callsign for the Packet mode.

For each channel an own callsign can be defined temporarily. After a disconnect the callsign will always be taken from channel 0 again.

After switching on the PTC-IIpro the firmware checks if a valid callsign is written in the PACTOR-MYCALL. In this case (i.e. no \*SCSPTC\* defined as PACTOR-MYCALL), the PTC-IIpro copies the PACTOR-MYCALL to all PR channels which are still having SCSPTC as MYCALL, and overwrite the SCSPTC with the valid mycall. If the **MYcall** command is executed on the PACTOR side with a valid callsign as an argument, the PTC-IIpro also checks all PR channels for SCSPTC, and if necessary the new defined PACTOR-MYCALL is taken over to the PR channels replacing the SCSPTC setting.

### 9.6.26 MYMail

**Default setting: MYCALL-8**

Parameter: CALL Callsign of the PR mailbox.

Identical to the **MYcall** command in the **pac:-**menu, however sets the *Mycall* of the PTC-IIpro PR-mailbox (BBS-MYCALL). The BBS call is set automatically to MYCALL-8, either at the first start (when the *Flash-Call* in the BIOS has been defined), or when ones own PACTOR-MYCALL has been set. If, for example, DL1ZAM is given as the first PACTOR-MYCALL then the PR-mailbox can be connected with the call DL1ZAM-8.

### 9.6.27 PACLen

Multiport

**Default setting: 255**

Parameter: X 1... 255, transmit packet length

Sets the maximum PR transmit packet length, when the PTC is in Terminal mode. (In hostmode is the **PAClen** value not used, as the hostmode program itself defines the packet length). Packet lengths smaller than 255 are only useful if the link to the distant station has a lot of errors. The PTC-IIpro sends in terminal-mode a packet immediately if a <CR> is received, which is the usual *sendpack-character*.

### 9.6.28 PErsist

Multiport

**Default setting: 64**

Parameter: X 0... 255, persistence.

The persistence value sets the probability that a packet is transmitted, after the radio channel is acknowledged as free.

Persistence on port 1 set to 32:

**pac: PE** 1:32 <Return>

### 9.6.29 Port

**Default setting: depending on installed Modems.**

Parameter: X 1... 2, default port.

The default port is set here, the **Port** command has influence to the following commands: **Baud**, **Connect**, **FSKFilter**, **Fulldup**, **PErsist**, **SLottime** and **TXdelay**.

### 9.6.30 PRBox

**Default setting: 1**

Parameter: 0 PR mailbox switched off.  
1 PR mailbox switched on.  
2 PR mailbox, only private messages

Enables the PR-mailbox to be switched on or off, or the mailbox to be configured as a *maildrop*. (*Maildrop* means that only data addressed to the PTC MYCALL will be accepted by the mailbox. This is a legal requirement in many countries, as an open BBS may only be operated by especially licensed stations). The function is similar to the **Box** command of the PACTOR level (**cmd:-prompt**). The **Box** command relates to PACTOR/AMTOR only. The **PRBox** command to Packet-Radio only.

### 9.6.31 Quit

Exits the Packet mode. Returns to the **cmd:** input prompt.

### 9.6.32 RESptime

**Default setting: 500**

Parameter: X 1... 30,000, response time delay

Sets the value for the AX.25 timer-2 (T2) in milliseconds.

After receiving a packet the PTC-IIpro waits the time T2 to check if another packets follow. If so, all packets can be confirmed with only one control packet.

### 9.6.33 REtry

**Default setting: 10**

Parameter: X 0... 255, number of repeats.

**REtry** sets the maximum number of repeats, and, if this value is exceeded, then the PTC-IIpro gives out the message:

LINK FAILURE with <call>

### 9.6.34 Setchn

**Default setting: 1**

Parameter: X 0... 31, channel.

Switches between the various channels.

The PTC-IIpro provides 32 logical channels to the user, numbered from 0 to 31. The **Setchn** command defines the channel to be written on. A special status has the channel 0. Channel 0 is the channel to transmit not protocolled messages, as CQ calls or beacon.

Connect attempts can be started from each channel between 1 to 31, as long the channel is not occupied. Received connects will always be assigned to the first free channel, provided that the number of maximal permitted simultaneous connects (**Users** command) is not exceeded.

### 9.6.35 SLovertime

Multiport

**Default setting: 100**

Parameter: X 1... 30,000, slot time in milliseconds.

Sets the slot time for the transmitter control.

The PTC-IIpro can transmit at particular times only. **SLovertime** defines the period between these times.

### 9.6.36 TRACE

**Default setting: OFF**

Parameter: OFF Trace mode switched off.  
ON Trace mode switched on.

In the terminal mode the PTC-IIpro provides the so called Trace mode for Packet-Radio. The **TRACE** command activates or deactivates a special display mode for all frames shown in the monitor channel. The PTC-IIpro sends the trace mode data as Hex-dump, as ASCII or as *shifted* ASCII in three columns. Finally the normal monitor packet is displayed additionally. As a horizontal separation between the frames a line out of = characters is given. Primarily this function is used for testing. In the WA8DED host mode this function is not available!

### 9.6.37 TXdelay

Multiport

**Default setting: 100**

Parameter: X 0... 30,000, TxDelay in milliseconds.

Sets the time between keying the PTT and the initial transmission of data.

Setting TxDelay of Port 1 to 50 ms.

**pac: TXD 1:50 <Return>**

Setting TxDelay of Port 2 to 200 ms.

**pac: TXD 2:200 <Return>**

### 9.6.38 TXLevel

Multiport

**Default setting: A 300, F 800**

Parameter 1    A    Tx-level for AFSK = 300/1k2 Baud

                  F    Tx-level for FSK = 9k6/19k2 Baud

Parameter 2:    X    20... 3000, Tx-level in millivolts (peak-peak).

The audio output level of the **SCS**-DSP-PR-module is set with the command **TXLevel1** (certainly only when a DSP-PR-module is installed!). The output level is set for the FSK (9600 and 19200 Baud) and AFSK modes (300 and 1200 Baud) independently.

Setting TxLevel for 300 and 1200 Baud to 100 mV:

**pac: TXL A 100 <Return>**

Setting TxLevel of the module on Port 2 to 500 mV:

**pac: TXL 2:A 500 <Return>**

Setting TxLevel for 9600 and 19200 Baud to 500 mV:

**pac: TXL F 100 <Return>**

Setting TxLevel of the module on Port 1 to 3000 mV (9600 and 19200 Baud):

**pac: TXL 1:F 3000 <Return>**

Without entry of a second parameter the actual values can be read out.

Reading out the TxLevel for 300 and 1200 Baud:

**pac: TXL A <Return>**

Reading out the TxLevel for 9600 and 19200 Baud:

**pac: TXL F <Return>**

Certainly, also here the port can be specified.

**pac: TXL 1:F <Return>**

**pac: TXL 2:A <Return>**

Without any parameter given, the entry of **TXLevel1** displays both amplitude settings.

The baudrate values for ports with the **SCS** DSP-Modem are stored in the Flash-ROM and remain valid also after a **REStart** or a firmware update.

### 9.6.39 Unproto.

**Default setting: CQ**

Parameter: Call Callsign for Unproto

**Unproto** sets the target callsign for the Unproto operation.

To start an Unproto transmission, just enter the Converse mode with **K**, and, everything that is then typed, and ends with <Return> is transmitted by the PTC-IIpro.

<Esc> returns the **pac**:-prompt, the entry of **K** then ending the Converse mode.

### 9.6.40 USers

**Default setting: 4**

Parameter: X 0... 31, number of users.

Limits the number of channels available for remote users.

**USers 5** limits the number of connects from outside to five, so if the PTC is presently connected to by 5 stations, and a further station attempts to connect, this connect request will be refused.

The **USers** command allows any incoming PR-connect to be transferred to the PTC-IIpro PR-mailbox, but only if **USers** has to be set to 0. This will allow for example, that on exiting the terminal program, (e.g. automatic de-initialization with **Y0** in **GP**) the PTC-IIpro can be brought to a condition where a connect using the *normal MYCALL* (i.e. without the -8) will be transferred to the mailbox. This is useful, as many potential users would use the *normal MYCALL* to connect to the PTC-IIpro.

If the terminal is *off-line*, and the configuration is correct, (**USers 0** or **Y0**) then all calls, irrespective of if they are the *normal MYCALL*, the *MYALIAS*, or the *BBS-MYCALL*, will be transferred to the PTC-mailbox.

The **USers**-command has no effect on self initiated connects, the number of channels is not limited for the user. It is thus possible, with **USers = 0** to initiate up to 31 PR-connects in parallel!

## Chapter 12

### 10 Hostmode

The hostmode was developed from **WA8DED** in 1986 in as an alternative firmware for TARP-TNC's to enhance the communication between computer (the host) and the connected TNC.

In the terminal mode the TNC is allowed to transfer data at any time to the computer, but in the hostmode the TNC is only allowed to send data if being polled by the computer. This has the advantage that the computer definitely knows when the TNC sends data, i.e., the computer controls the data transfer between computer and TNC. This ensures that the data of each channel will be displayed in the correct window of the hostmode program.

Because of this complete control of data exchange between computer and TNC and because of the hostmode structure, a transfer of binary files is possible without problems, and this on several channels at the same time. Special encoders like UUENCODE, 7PLUS, YAPP are not necessary anymore.

As there was no source code for the **WA8DED** firmware available, some German radio amateur (from the **NORD><LINK**) decided to program an own firmware. The ideal was the **WA8DED** firmware inclusive hostmode for best compatibility to existing programs. So the **NORD><LINK-TheFirmware** was created, short form **TF**. Already from the beginning the source code of **TheFirmware** was available for anyone, so that radio amateurs could modify and improve it. Especially for new ideas like extended hostmode and AX.25 protocol expansions like as **DAMA TheFirmware** was and is the *basis for development*.

Because of these advantages, the wide distribution of **TF** and the always more perfected hostmode programs, the hostmode became the standard for TNC controlling.

But the disadvantages of the hostmode shall be mentioned too. The hostmode program has to poll the TNC continuously, if data is available or not. That means the program has to poll in a turn each channel after the other for data. This causes a delay until the data becomes displayed on the monitor. But the polling is reduced using the extended hostmode (refer to chapter 10.5, page 182). Another disadvantage is the high *load* at the serial interface caused by multiple transfers of data, i.e., if the monitor is switched on the receive-data are transmitted once on the monitor channel and once on the receiving channel to the computer. This disadvantage is visible especially when using high speed packet (9k6 or higher).

#### 10.1 The PTC-IIpro hostmode

The hostmode implemented in the PTC-IIpro is largely compatible to the **WA8DED** hostmode, as found in virtually all TNC's, but is only used when the PTC-IIpro is connected to a computer, and controlled by a special hostmode program (e.g. **GP**, **SP**, **WinGT**, **WinPR**, **TNT**, etc.).

## 10 Hostmode

After starting the **WA8DED** hostmode the PTC-IIpro displays in the monitor channel a short startup message with version number of the firmware and the PTC-IIpro BIOS. Additionally all installed modems and the baud rates being set are displayed:

```
*****
*   SCS PTC-IIpro Multimode Controller   *
*   Firmware Version V.2.8 Level 2      *
*   BIOS Version 1.32                   *
*   (C) 1994-1999 SCS GmbH - Germany    *
*****
PORT 1: SCS - HIGH SPEED / DIRECT FSK MODEM at 9600 baud.
PORT 2: SCS - HIGH SPEED / DIRECT FSK MODEM at 9600 baud.
```

Display 10.1.1: hostmode Start message

If you want to control the PTC-IIpro directly after starting with a hostmode program, the baud rate should be set with the **SERBaud** command to a fixed value (refer to chapter 6.87, page 101).

Please refer for more information to chapter 5.14, page 58 and the explanations according to the **TNC** command, chapter 6.96, page 109.

## 10.2 Modern Times

We hope you have already recognized the following warning:

The PTC-IIpro expects a time input in milliseconds!

The settings of the time parameters are very important for proper Packet-radio operation! How long to wait for the confirmation (**F**). How long is the time until it is checked if the other station is still available (**@T3**), etc. The function and most of all the reliability of a Packet-Radio connection depends on the time parameters.

Because of this, check the initialization files of programs you use in advance and very carefully. Often the added examples are designed for a TNC 2. But the TNC 2 expects the time inputs in 10 ms steps, e.g. for a TxDelay of 100 ms the value 10 has to be given for a TNC 2! But the PTC-IIpro needs the value in milliseconds, that means 100.

If you use the initialization files without checking, it could happen, that the very important timing data becomes 10 times too low.

The *most frequently* done mistakes according to wrong times are:

- At connect establishment all attempts of the PTC-IIpro are transmitted in very short distances.
- On a DAMA-Digi it could happen that suddenly the connection hangs. Digi and PTC-IIpro exchange RR frames only.

Please search for the following commands, **F**, **T**, **W**, **@T2** and **@T3**, in the initialization file of your program and check the settings. In any case you have to adjust the TX delay (command **T**) due to your needs. It is possible to remove all other commands within the initialization file or take the default settings.

### 10.3 DAMA

The PTC-IIpro in Packet-Radio is full compatible with the  DAMA (Demand Assigned Multiple Access) standard. You easily recognize a DAMA-Digi with a look to your monitor. The expression [DAMA] is added to the header of the monitored packets, if the packet is received by a DAMA-Digi. The DAMA mode needs not be activated by the user. The PTC-IIpro automatically notices if you are working with a DAMA-Digi or not and behaves respectively.

### 10.4 Commands

The commands available in the hostmode are totally different to the commands in the terminal mode. [Table 10.1](#) compares the commands between the terminal mode and the hostmode.

Terminal Mode	Hostmode	Terminal Mode	Hostmode
Baud	%B	MCon	M
CHEck	@T3	Monitor	M
CMsg	U	MStamp	K
Connect	C	MYcall	I
CONStamp	K	PErsist	P
CText	U	Port	%P
Disconnect	D	RESptime	@T2
FRack	F	REtry	N
FSKFilter	%F	SLottime	W
FUlldup	@D	TXdelay	T
MAXframe	O	Users	Y

Table 10.1: Commands: Terminal mode / hostmode

Also in the hostmode some commands have effect on each port separately (refer to [chapter 9.4](#), page 149). These commands are marked in the command list with “Multiport”. The general syntax for multiport commands is as follows:

Command Port:Parameter

Between the port setting, the colon and the parameter are no spaces allowed!

The following examples use the **T** command which is to define the TxDelay:

Readout the setting of **T** on Port 1:

```
T 1: <Return>
```

Readout the setting of **T** on Port 2:

```
T 2: <Return>
```

Change setting of **T** on Port 1 to 200 ms:

```
T 1:200 <Return>
```

Change setting of **T** on Port 2 to 90 ms:

```
T 1:90 <Return>
```

If a special port is preferred, it is annoying to enter the port together with the command each time again. To make it easier a default port can be defined using the command **%P**. All multiport commands will then be valid for this port when the port setting is not entered. The following command defines the port 2 as default:

```
%P 2: <Return>
```

After this setting all multiport commands without a special port entry are for port 2.

Readout the setting of **T** (Port 2):

```
T <Return>
```

Change setting **T** on to 150 ms (Port 2):

```
T 150 <Return>
```

The PTC-IIpro still expects all time values in milliseconds!

In the following chapters the hostmode commands are described:

### 10.4.1 C

Multiport

**Default setting: none**

Parameter: <target call> [<Digi1> <Digi2>...].

Connect establishes a AX.25 link. The connect can take place over both ports in the PTC-IIpro, the required port being given directly before the target callsign:

```
C 1 :DL1ZAM - connects with DL1ZAM via port 1
```

```
C 2 :DL2FAK - connects with DL2FAK via port 2
```

If no special port is given, then the PTC-IIpro uses the default port that is set using **%P**.

If the link takes place via one or more digipeaters, then the list of digipeaters should be given directly after the target callsign.

**C** DL6MAA DB0FKB - connects to DL6MAA via DB0KFB

A Connect command on channel 0 sets the path for the Unproto transmission.

### 10.4.2 D

Disconnects an AX.25 link.

If there is still data to be sent to the partner station, this data is transmitted first, then the disconnect is carried out.

If the Disconnect command is given twice, one after the other, then the link is broken immediately (corresponding to **DD** in PACTOR).

### 10.4.3 F

**Default setting: 5,000**

Parameter: X 1... 15,000, time in milliseconds

Frack-Timer (T1).

Frack sets the time in which a packet must be acknowledged. If the PTC-IIpro sends a packet, and no acknowledgment is forthcoming within the Frack time, the PTC-IIpro then queries whether the information has arrived.

### 10.4.4 G

**G** (Get) is a special hostmode command, and is used to get information about the various hostmode channels.

This command is only used by the hostmode program. The user cannot enter this command.

### 10.4.5 I

**Default setting: SCSPTC**

Parameter: CAI Station callsign

Sets the station callsign, which can be individually set for each channel., the callsign from channel 0 being used after a disconnect

### 10.4.6 JHOST

**Default setting: 0**

Parameter: 0 Exit hostmode  
          1 Start hostmode  
          4 Start CRC hostmode

Switches to the hostmode or exits.

This command is used by the hostmode software, in order to switch to hostmode, the command has no meaning for the *normal* operation in terminal mode.

### 10.4.7 K

**Default setting: 0**

Parameter: 0 Time stamp switched off.  
          1 Time stamp for connect and disconnect messages.  
          2 Time stamp also in monitor.

Switches the time stamp display on and off.

### 10.4.8 L

**Default setting: none**

Parameter: X 0... 31, channel

Requests the link-status, a list of the channel condition being given.

This command is only used by the hostmode program. The user cannot enter this command.

### 10.4.9 M

**Default setting: N**

Parameter: N Monitor switched off.  
          I Info frames  
          U Unproto transmissions.  
          S Control packets  
          C Monitor also while connected

**M** sets which frame types will be displayed in the monitor.

### 10.4.10 N

**Default setting: 10**

Parameter: X 0... 255, number of repeats.

Sets the maximum number of repeats, and if this value is exceeded, then the PTC-IIpro gives out the message:

```
LINK FAILURE with <call>
```

### 10.4.11 O

Multiport

**Default setting: 7**

Parameter: 1 1... 7, Number of unacknowledged packets

Maximum number of unacknowledged info packets (I frames) in a link. Maxframe also sets how many packets the PTC-IIpro transmits together. The value should be reduced for bad links.

### 10.4.12 P

Multiport

**Default setting: 64**

Parameter: X 0... 255, persistence

The persistence value sets the probability that a packet is transmitted, after the radio channel is acknowledged as free.

### 10.4.13 PS

When a GPS receiver is connected to the PTC-IIpro then with the **PS** command the position data can be read out. In opposite to the **POSITION** command in the **cmd:** - menu the output always has NMEA format. The NMEA compatible string usually looks like:

```
$GPRMC,212234,A,5005.432,N,00845.974,E,000.0,360.0,190201,000.1,E*7B
```

### 10.4.14 T

Multiport

**Default setting: 100**

Parameter: X 0... 30,000, TxDelay in milliseconds.

Sets the time between keying the PTT and the initial transmission of data.

**T** 1:50 sets the TxDelay on port 1 to 50 ms

**T** 2:200 sets the TxDelay on port 2 to 200 ms

### 10.4.15 U

**Default setting: 0**

Parameter: 0 Switch connect text off.  
1 Switch connect text on.  
2 Switch connect text on and analysis of special functions.

Enable or disable the connect text.

**U** defines the connect text.

**U** 1 Here is the PTC-IIpro – The PTC-IIpro switches on the connect text and the text will be “Here is the PTC-IIpro ”.

**U** 1 – asks for the connect text

**U** 0 – switches off the connect text

If **U** is set to 2, the sequences `//B <CR>` and `//Q<CR>` are accepted additionally. The two sequences are recognized if they occur at the beginning of a line and are closed directly with `<CR>` or `<Return>`.

`//B` initiates the sysop-bell (duration about 14 seconds). After receiving `//Q` the PTC initiates a disconnect.

The sysop-bell is set using the **BE11** command of the **cmd:-**menu (refer to chapter 6.11, page 66)

### 10.4.16 V

Gives a longer version string.

### 10.4.17 W

Multiport

**Default setting: 100**

Parameter: X 1... 30,000, slot time in milliseconds.

Defines the slot time for the transmitter control.

The PTC-IIpro can transmit at particular times only. **w** (Slottime) defines the period between these times.

### 10.4.18 Y

**Default setting: 4**

Parameter: X 0... 31, number of users.

Limits the number of channels available for remote users.

**Y** 5 limits the number of connects from outside to five, so if the PTC is presently connected to by 5 stations, and a further station attempts to connect, this connect request will be refused.

The **Y** command allows any incoming PR-connect to be transferred to the PTC-IIpro PR-mailbox, but only if **Y** has to be set to 0. This will allow for example, that on exiting the terminal program, (e.g. automatic de-initialization with **Y0** in **GP**) the PTC-IIpro can be brought to a condition where a connect using the *normal MYCALL* (i.e. without the -8) will be transferred to the mailbox. This is useful, as many potential users would use the *normal MYCALL* to connect to the PTC-IIpro. If the terminal is *off-line*, and the configuration is correct, (**Y0**) then all calls, irrespective of if they are the *normal MYCALL*, the *MYALIAS*, or the *BBS-MYCALL*, will be transferred to the PTC-mailbox.

The **Y**-command has no effect on self initiated connects, the number of channels is not limited for the user. It is thus possible, with **Y** = 0 to initiate up to 31 PR-connects in parallel!

### 10.4.19 @B

Shows the free buffer available.

This command is virtually only used from the hostmode program to find out how much memory is still free in the PTC-IIpro.

This command is only used by the hostmode program. The user cannot enter this command.

### 10.4.20 @D

Multiport

**Default setting: 0**

Parameter:	0	Full duplex disabled.
	1	Full duplex enabled.

Switches the port into full duplex operation, which allows the simultaneous transmission and reception of data at a port.

**@D** 1:0 <Return> Switches the full duplex on port 1 off

**@D** 2:1 <Return> Switches the full duplex on port 2 on

**@D** 0 <Return> Switches full duplex on the present port (default port) off

### 10.4.21 @F

The hostmode command **@F** allows to setup FAX reception under hostmode control. Receiving FAX images through the hostmode interface means that the data transfer between modem and PC is highly buffered and error-corrected (CRC hostmode). Thus "Skew" or "jumps" within FAX images caused by data loss on the interface side (high PC operating system latency, etc.) can be completely avoided. Besides that, the **@F**

command eases incorporating FAX reception to application software that mainly builds on the hostmode.

**Default setting: none**

- Parameter: @F (no parameter) Clears the FAX data buffer, see below.
- @F0 Disables hostmode FAX reception and switches back to normal PACTOR Standby operation.
- @F1 Activates hostmode FAX reception in FM-FAX, sampling rate = baudrate/32.
- @F17 Activates hostmode FAX reception in FM-FAX, sampling rate = baudrate/16.
- @F2 Activates hostmode FAX reception in AM-FAX, sampling rate = baudrate/32.
- @F18 Activates hostmode FAX reception in AM-FAX, sampling rate = baudrate/16.

If hostmode fax reception is activated, 8 bit per sample (grey scale) FAX data is available on hostmode channel 252. The data field length of the hostmode packets on channel 252 is always 256. The sampling rate (number of 8 bit samples, i.e. pixels, per second) is calculated as baudrate on the serial user interface (COM port) divided by 32 or 16. The baudrate on the serial user interface of the modem should be chosen as high as possible (higher than 57600 Bd) to achieve a good FAX resolution. For example, 115200 Bd on the serial port yield a FAX sampling rate of 3600 or 7200 pixel/sec, respectively. If the baudrate is equal or less than 2400, the sampling rate is set to a constant value of 75 samples/sec, however FAX reception at baudrates below 19200 Bd generally does not make much sense because the image signal then suffers from heavy undersampling.

The hostmode FAX demodulators (AM/FM) have the same properties as the corresponding FAX demodulators in terminal mode (**fax:-**menu). All parameters accessible through the **fax:-**menu which have an effect on the FAX demodulator remain also valid for hostmode FAX reception. Any change of the FAX parameters from the default settings should be performed unter terminal mode control (fax: menu) prior to starting the hostmode.

All FAX receive data is buffered through the 4096 samples long FAX data buffer (see @F command without argument). If a buffer overrun occurs (frequency of data polls by the PC program too low), the buffer is automatically cleared again (4096 samples are lost). Besides that, the FAX buffer is always cleared automatically when hostmode FAX reception is activated.

When hostmode FAX reception is active, all PACTOR relevant functions/tasks are blocked, i.e. PACTOR calls can neither be initiated nor be accepted. (Not all corresponding commands are blocked. The user itself must be aware of this if a PC application program does not already limit the command set available during hostmode FAX operation.)

All other processes which do not access the HF port (UHF/VHF Packet Radio, particularly the TRX control) are still available during hostmode FAX reception.

The “extended hostmode” logic (channel 255) includes channel 252.

### 10.4.22 @S

If hostmode FAX reception (refer to 10.4.21, Page 175) is activated, the additional hostmode command @S is available. It allows access to the 16 bit wide audio samples from the A/D converter on the HF port. The @S command does not require a parameter. The audio sampling rate is 9600 samples per second and cannot be changed. As soon as the modem recognizes a @S command, it starts acquiring 1024 16 bit samples on the HF port. The samples are directly (no filtering, no AGC) written to a data buffer and can be retrieved from there on hostmode channel 251. Thus the modem generates 8 hostmode data packets (with data field length 256) per @S command. Every 16 Bit sample is split into 2 bytes, the less significant byte (lower half of the 16 bits) appears first.

The @S command can be used for displaying the frequency spectrum of the input signal on the HF port.

The “extended hostmode” logic (channel 255) includes channel 251.

### 10.4.23 @T2

**Default setting: 500**

Parameter: X 1... 30,000, response time delay

Sets the value for the AX.25 timer 2 (T2) in milliseconds.

After receiving a packet the PTC-IIpro waits the time T2 to check if another packets follow. If so, all packets can be confirmed with only one control packet.

### 10.4.24 @T3

**Default setting: 300,000**

Parameter: X 0... 3,000,000, time in milliseconds.

The @T3 command sets the T3 or link activity timer. If nothing is received from the distant station for the time T3, then the link status is polled.

### 10.4.25 %B

Multiport

**Default setting: 1200 or 9600**

Parameter: Rx Rx baud rate for the radio link.

Tx Tx baud rate for the radio link.

Setting / checking the radio link baud rate.

Without a parameter, the %B command shows the modem type and the baud rate as set. If a valid baud rate is given as parameter it is set in the Packet modem. Valid baud rates are:

- For the **SCS** DSP-Modem: 300, 1200, 9600, 19200.
- For the **SCS** AFSK-Modem: 1200 and 2400.
- For the **SCS** FSK-Modem: 4800, 9600, 19200, 28800, 38400, 57600, 115200.

## 10 Hostmode

---

Some digipeater work with higher baud rate in direction to the user than at the *Upload* side, e.g. Digi→User 19k2 and User →Digi 9k6.

The Baud command allows two arguments, e.g. %B 19200 9600

The first argument is the receiving baud rate, the second one is the transmission baud rate. If only one argument is set, the PTC-IIpro uses this value for both, TX baud rate and RX baud rate, e.g. %B 9600 <Return>

It is also possible to enter the port directly, e.g. %B 2:19200 9600 <Return>

The baudrate values for ports with the **SCS** DSP-Modem are stored in the Flash-ROM and remain valid also after a **REStart** or a firmware update.

### 10.4.26 %C

This is identical to the **CLR** command in the main menu of the terminal-mode. It works only on the PACTOR-channel.

### 10.4.27 %E

**Default setting: 6**

Parameter: X 1... 7, brightness value.

Identical to the **BRightn** command of the main menu in the terminal mode. This serves to set the brightness of the LED display between 6% and 100%. The parameter 1 is equivalent to 6% of the maximum brightness. Parameter 7 represents 100%.

### 10.4.28 %F

Multiport

**Default setting: 0**

Parameter: X 0... 15, Filter parameter for the **SCS** FSK modem.

This command is only valid in connection with **SCS** FSK modem!

The filter parameters provide a certain adaptation of the signal to the frequency transfer characteristics of the transceiver. In most cases, good results are already obtained using the default setting 0. If any problems occur when connecting a certain digipeater, another value should be tried.

The filter parameter are apülicable only for transmission!

### 10.4.29 %I

Initiates a BREAKIN. Works only in the receiving condition (*IRS*) (SEND bit in the status byte = 0).

### 10.4.30 %L

**Default setting: 1**

Parameter: 0 PACTOR listen mode switched off.  
          1 PACTOR listen mode switched on.

Turns PACTOR listen mode on (1) or off (0).

### 10.4.31 %M

**Default setting: 0**

Parameter: 0 hostmode expansion switched off.  
          1 hostmode expansion switched on.

The parameter of the %M command activates the respective hostmode terminal expansion. At a hostmode start, it is always set to 0. (The hostmode program must choose the respective amount of expansion it needs for itself after the start. This greatly eases step by step software expansion).

If a too high value is chosen, (that cannot be interpreted by the PTC due perhaps to an older firmware version), the PTC answers with an error message (code byte=2) which contains the maximum possible argument value.

**%M0** - Switches the hostmode terminal expansion off.

(This command is normally not needed by the terminal program, as the %M parameter is automatically set to 0 at hostmode start.)

**%M1**- *delayed echo* is output with Code-byte=8.

(With PR up until now, even with %M1, no "delayed-echo" has been given, as this function is better done over the monitor channel data stream which can even handle self sent packets.)

Note: Code byte 8 is not defined in **WASDED**-hostmode, and is used to define a special extension of the PTC-IIpro. Terminal programs which wish to work with the *delayed echo* in hostmode, must logically be appropriately extended to contain this feature, and choose the extension required automatically. Manual switching of the hostmode expansion is not to be recommended due to possible incompatibilities.

### 10.4.32 %O

Performs a CHANGEOVER. This command can also be used in the receiving condition (☞ *IRS*). In this case, it leads to a BREAKIN.

During transmission (☞ *ISS*), the %O will be executed when all characters in the transmission buffer are completely sent and confirmed.

### 10.4.33 %P

**Default setting: depending on installed Modems.**

Parameter: X 1... 2, default port.

The default port is set here, the %P command has influence at the following commands:

C, P, T, W, @D, %B and %F.

### 10.4.34 %T

Displays the total number of bytes that have been sent and confirmed in PACTOR so far. The value is reset at the end of each connection. The number can also be reset by giving an argument behind the %T command. The format is identical with the standard decimal ASCII output as used in the hostmode.

### 10.4.35 %V

Displays a short ASCII string containing the actual version number of the actual version number of the PTC-IIpro firmware and the actual version number of the PTC-IIpro BIOS.

Format for example: 2.8 1.32

Characters left of the dot are the main version number of the firmware. Characters after the first dot until the first blank character are the sub-firmware version number. Letters may also appear here. At least one blank separates the firmware version number and the BIOS version number. The BIOS version string is built in the same way, the convention just refers to the second dot this time.

### 10.4.36 %W

**For synchronizing external scanners**

Possible arguments: 0 or 1 (ASCII).

All responses to the %W command are null-terminated ASCII strings.

The %W command enables synchronizing between the PTC and external frequency scanners. Examples for external frequency scanners are AirMail and WinLink2000. These PC programs subsequently search for incoming user calls on some different channels, changing the actual frequency by its own without the aid of the internal PTC scanner (trx:-menu). Thus there exist a (small) risk that a frequency change occurs when the internal scanner would not allow/perform a frequency change or more generally speaking when a frequency change is prohibited due to a special actual state of the modem, e.g. when the modem has already detected the beginning of a user access on the PACTOR HF port.

In principle this problem can already be solved by using the scan-stop signal the PTC provides - but only if the external scanner immediately recognizes the scan-stop signal. Unfortunately, so-called latency time (Windows) is introduced in practise. Latency time delays the scan-stop signal and thus can cause "prohibited" frequency changes. An example of a typical szenario: A user calls on channel A. The PTC has already detected

that it is being called and asserts the scan-stop signal - but unfortunately some time (latency) elapses until the external scanner finally receives the scan-stop information. Therefore, it's not unlikely that the scanner still changes the frequency (during the latency period) to channel B although the PTC has already indicated that the scanner should stop operation. The result is catastrophic: The system responds on channel B although the user called on channel A. The connection fails.

The %W command fully resolves this problem with the aid of a special mechanism, regardless of the amount of latency introduced.

### **Usage of the %W command:**

Prior to every scheduled frequency change the external scanner must send a %W[0] command to the PTC: (Parameter 0 is optional but should be given in order to make sure upward compatibility.)

#### **%W[0]**

Possible response of the PTC: 0 or 1.

- 0: Scan-Stop! Currently the frequency **MUST NOT** be changed! (After that, if the modem does not indicate a connection to a user within a few seconds, the %W0 command should be resent to the modem, and so on.)
- 1: Currently the frequency can be changed, scanning need not to be suspended because no link establishment is in progress. Response "1" also indicates that the modem has entered the so-called WAIT state. If the modem is in WAIT state, it does not accept user calls on the HF port (it cannot be connected by a user) any more.

Now the external scanner can perform a frequency change. After that it must release the modem from WAIT state by sending %W1 to it. After receiving the %W1 command the modem again accepts user calls on its HF PACTOR port.

#### **%W1**

Possible response of the PTC: none.

Release from WAIT state. The modem enters the normal "standby state" again and waits for incoming user calls.

Note: WAIT state always automatically times out after 10 seconds.

**The following chapters are only applicable for software authors! If you do not want to write your own hostmode program you can skip the following chapters.**

## 10.5 Extended hostmode

The PTC-IIpro supports the so called *extended hostmode*. The extended **WA8DED**-hostmode has established itself as a *de-facto standard* for communication between TNC/PTC and PC-control programs.

The *extended hostmode* makes the polling of the channels much easier and thus reduces the polling overhead.

In the *extended hostmode*, channel number 255 is dealt in a special way. A G command to channel 255 leads to the output of "255,x,y,z,...,0" from the TNC. x, y, x, etc. are the numbers (binary and increased by one) of the channels that contain new information, which can be requested with the G command. The string given by the TNC on a poll of channel 255 always ends with "0".

If, for example, only the monitor channel contains new information, the answer string of the TNC to a G-poll of channel 255 is 255,01,01,0. If there is no new information to be received, the output is 255,01,0 (255,0 is also possible). If there is new information in channel 2 and 3, the string is 255,01,03,04,0. The channel numbers are usually given in increasing order - at least the PTC-IIpro follows this recommendation.

With the *extended hostmode*, a continuous cyclic polling of every single channel with the G command has thus become obsolete, just channel 255 needs to be polled regularly. If the result indicates that there is information in any other channel, only the respective channel has to be polled using the G command to get the data.

## 10.6 Status output in hostmode

The usual status byte can be called in the hostmode by polling channel no. 254. A G poll of this channel always outputs a string containing the actual status information of the PTC-IIpro. The format is: 254,07,0,S. (S = binary status byte). It is hence a *byte-count format*:

channel number, code, length minus one, information byte(s).

The code of the status information is 07. According to the **WA8DED** standard, this would also relate to *information from a connection*, which, however, is usually used as a byte count format on channel 254.

In future releases, the status information is planned to be expanded to several bytes. Using the length information from the **WA8DED** standard, a longer status information will not lead to any problems of compatibility. The terminal program can utilize exactly that number of bytes that are interpretable by the respective software. Newer expansions can easily be ignored that way.

The G poll command on virtual hostmode channel 254 ("status channel") can be extended by a single parameter in ASCII format, valid range 0-3, e.g. G1. The parameter determines, how many status bytes are sent back to the PTC as a response to the G poll. The number

of bytes calculates as parameter value plus 1. Thus the command G0 is compatible with the usual G poll without argument because it yields exactly ONE status byte, the old, “normal” status byte. Therefore, a maximum of 4 status bytes can be requested by the application software.

The contents of the status bytes is as following:

Byte 1: „normal“ (old/usual) status

Byte 2: PACTOR connect level:  
0: not connected,  
1: PACTOR-I,  
2: PACTOR-II,  
3: PACTOR-III.

Byte 3: “Speedlevel“ (submode of a PACTOR level):  
0-1 on PACTOR-I,  
0-3 on PACTOR-II,  
0-5 on PACTOR-III.

Byte 4: Signed, actual receive frequency offset. Value 128 (= -128 ) is invalid and thus should be ignored by the application software. This helps to avoid “glitches” because the frequency byte only gets valid after the frequency detector has obtained a stable estimate of the frequency offset.

„Auto status“ is triggered by a change of the contents of byte 1 or byte 3.

### 10.6.1 Auto status in hostmode

If the status-format is set to 2 (please refer to the **STatus** command chapter 6.92), the PTC provides an automatic status also in the hostmode. This mode leads to an inclusion of channel 254 if a G poll is performed to channel 255 in the *extended hostmode*, and any change of the status has occurred in the meantime. The output could thus be: "255,01,255,0". This means that new status information is available on channel 254. The channel 254 in the G poll list of channel 255 (*extended hostmode*) is cleared after polling of channel 254. (When any status change occurs, channel 254 is added to the list again).

The normal G-poll of channel 254 is always possible, independent from new information in the status. Even if the auto status is active, the actual value can always be obtained by a regular poll.

### 10.7 TRX Control Channel on Hostmode

Virtual hostmode channel 253 serves as transparent data channel between PC and TRX port. Arbitrary data can be exchanged between PC and transceiver on channel 253. This enables, for example, direct transceiver remote control from the PC side. There is one length limitation: If more than 1000 bytes of data sent from the transceiver are already buffered, the PTC does not accept more data until the buffer is flushed (data fetched by the PC application).

## 10.8 NMEA-Channel

On hostmode channel 249 the PTC-IIpro provides **all** NMEA sentences of a connected GPS receiver. Except the terminating <CR> (ASCII13) the data is exactly matching with the one the GPS receiver sends. The PTC-IIpro buffers 32 sets of NMEA data internally. This NMEA channel is also included in the *extended hostmode* channel 255, which means that the usual poll on channel 255 is sufficient to determine if there is new NMEA data available on channel 249.

## 10.9 CRC hostmode

The expanded **WA8DED** hostmode (*extended hostmode*) has established itself as a de-facto standard for communication between TNC/PTC and PC control programs.

Although containing a very well thought out structure, which considerably eases compatibility of extensions, the **WA8DED** hostmode has two basic weak points, which can cause serious problems with data corruption or loss during operation:

1. There is no reasonable possibility for a resynchronization of the hostmode operation if through any reason the synchronization is broken. (Even if a new synchronization does occur, it is highly probable that it will cause defective data transfer during the synchronization phase).

In the worst case, it only needs one destroyed bit in the data flow between the PC and the TNC to cause a hostmode crash.

2. Defective data cannot be uniquely identified, and it is not possible to request repetition of destroyed data. The data security in the link between the PC and the TNC has a weak point here. A correct transfer of sensitive data (such as program data in 7PLUS formator direct binary data) via an insecure **WA8DED**-hostmode cannot therefore be fully guaranteed.
3. Data transmission via multiple nodes (e.g. **WINLINK** forwarding) increases the potential for error due to corruption via the RS-232 links.

Possible sources of error:

- During active transmitter operation, HF can corrupt data.
- Short spikes due to heavy loads being switched on or off on the AC power line, or through close lightning strikes etc. They can all cause error bursts, especially on longer RS-232 lines.
- Slow or wrongly configured multitasking systems (WINDOWS) tend to *swallow* a character or even complete pieces of text, especially when the computer is heavily loaded. This is due to the overflow of (sometimes non-existent) buffers and also timing problems on the RS-232 interface itself.

The CRC-hostmode solves all these problems in that every hostmode data packet has a highly secure integrated CRC check sequence included. Errors can therefore be easily

detected. The CRC-hostmode protocol also allows the request for and the automatic re-transmission of packets recognized as containing errors.

### 10.9.1 Basic principles

The term *send packet* or *receive packet* has nothing to do with the data actually transmitted or received via the HF link. They concern themselves **only** with data present on the RS-232 interface. The # character means *Binary byte*.

The protocol is based on the *extended hostmode*. A number of data packets are built up according to this sub-protocol.

The HOST (PC) is, as in **WA8DED** mode, the MASTER. That means that every action is initiated by the PC. The TNC/PTC (SLAVE) may never send data with-out being first requested by the PC.

For every action by the MASTER, exactly one reaction from the SLAVE must follow. The Master must wait for this reaction before it starts any other new action. There is of course, a timeout allowed for this waiting time (see below).

Every **WA8DED** data packet is expanded by a (unique) header, consisting of #170 - #170.

Every **WA8DED** data packet is completed by the addition of two CRC data-bytes (binary). The CRC is calculated exactly according to the CCITT-CRC16, and is thus identical to that used for PR and PACTOR. The CRC is calculated from the first byte after the #170 - #170 header (channel number). (CRC see AX.25-protocol and example in the chapter [10.9.7](#), page [188](#)).

Directly before the transmission, thus at the lowest sub-protocol level, the data packet transmitter (MASTER and SLAVE) carries out so-called Byte-Stuffing. This prevents the #170 - #170 sequence from appearing within a packet.

The Byte-stuffing takes place directly after the 1st byte after the #170 - #170 header, and ends after the second CRC-byte. It therefore ranges over the complete packet (excepting the header). Also, even when the second CRC-byte has the value #170, this changes due to the stuffing. Stuffing means that after every byte with the value #170, a further byte with the value #0 is inserted. (The CRC calculation is only carried out on the original packet, not on the stuffed packet.) The packet counter concerns itself always with the original length of the packet (without stuffing!).

Directly after the packet is received, and thus at the lowest sub-protocol level, the packet receiver (MASTER and SLAVE) carries out a so-called Byte-de-stuffing. This removes the #0 bytes inserted by the packet transmitter. The byte-de-stuffing begins directly after the first byte after the recognized #170 - #170 header. After every byte with the value #170, one byte is erased, providing it is a #0 byte. (If the following byte does not have a value of "#0", then error handling is carried out, refer to chapter [10.9.4](#), page [187](#)).

The MASTER uses a 1 bit packet-counter, using bit 7 of the CMD/INF-bytes, that is incremented (= inverted) on sending a **new** (not repeated) packet. This packet counter (and request flag) allows the SLAVE to positively identify repeated MASTER packets.

The slave possesses the possibility to quickly inform the Master that the last transmitted packet should be repeated, by inserting a short request packet. The request packet has the format: "#170#170#170#85".

### 10.9.2 MASTER protocol

Definition of the MASTER-condition

- NACK-condition
  - When no reaction is received from the SLAVE within 250 ms after the MASTER transmitted packet has ended.
  - This is a minimum time. The PTC-IIpro answers within a few milliseconds. With very slow TNCs the waiting time can be changed in the MASTER program.

(Note: Timeout watchdog is stopped as soon as a packet-header is received (i.e. the packet starts being read in). The maximum useable data length of a *null-terminated* packet must not exceed 256).

  - If a packet-header is identified within 250 ms, a packet is read in, and a CRC error takes place.
  - If a request-packet is identified.
- ACK-condition
  - If a data-packet with the correct CRC is received.

Reaction of the MASTER to various conditions

- Reaction of the MASTER to an NACK condition.
  - Repetition (transmit) of the buffered last packet with the request-bit unchanged.
- Reaction of the MASTER to an ACK condition.
  - A new packet can be sent to the slave, if available. The request flag is inverted before the transmission. (Note: this packet must also be buffered in case a repetition is requested.)

### 10.9.3 SLAVE-protocol

Definition of the SLAVE-condition

- NACK-condition
  - If a packet-header is identified, but a CRC error takes place.
- ACK-condition
  - If a packet is correctly received (CRC OK) and the request flag is different compared with the last correctly received packet.
  - If bit 6 in the CMD/INF byte is set, then the condition of the request-flag in the last correctly received packet is ignored. Every correctly received packet with bit 6 in

the CMD/INF byte causes an ACK-condition. A request condition is thus impossible here.

- Request-condition
  - If a packet is correctly received, and the request-flag is identical to the last correctly received packet. (Bit 6 of the CMD/INF-byte must be erased. Refer to the text above.

Reaction of the SLAVE to various conditions

- Reaction of the SLAVE to the NACK-condition
  - Transmission of the special request-packet #170 #170#170#85. (direct request for a repetition of the defective packet without waiting for the MASTER-timeout NACK condition).
- Reaction of the SLAVE to the ACK-condition
  - Transmission of the present (new) response-packet (e.g. data packet if a G-POLL).  
NOTE: This packet must be buffered in case of a later repetition)
- Reaction of the SLAVE to the request-condition
  - Repetition of the last (buffered) packet. Information of the present received packet is not used, it is thrown away/erased.

#### 10.9.4 Stuffing errors or unexpected header sequences

- The sequence #170#0 during a header search is interpreted as an ERROR, and the header search carried on.
- Sequences between #170#1-#169 and #170#171-#255 during the header search AND during the packet read-in are interpreted as an ERROR and cause a *newstart*, i.e. the header search is started afresh.
- #170#170 ALWAYS leads to a *start of packet* condition, under all situations. The next byte is then appropriately interpreted as the channel number. (However after a start of packet is recognized, two #170 in a row must follow so that this *exception* can work again. This would be in the case #170#170#170...)

#### 10.9.5 Start of the CRC-hostmode

- The command that switches a TNC/PTC into hostmode is <ESC>JHOST4<CR>.
- After the start of the CRC-hostmode, the internal REQUEST-bit in the SLAVE (PTC) should be set to *not defined* so that either 1 or 0 are valid as REQUEST-BIT in the first transmit packet from the MASTER. Thus when the CRC is correct at the SLAVE, an ACK-condition follows. Independent of the above, it is recommended that the first transmit packet from the MASTER, after a hostmode start, or program start, should have bit 6 set, to ensure that a correctly received packet at the SLAVE always leads to an ACK-condition. (This allows the MASTER to start the protocol without having to know the condition of the (old) buffered RQ-flags at the SLAVE.)

## 10.9.6 Recommended baudrate

Due to the considerably higher overhead in the CRC-hostmode, it is recommended that the RS-232 data rate not be set lower than 19200 Bit/sec. There is otherwise the risk that the response time could be too long, and the effective data throughput, especially when multitasking with Packet-Radio, would be too slow for useful working.

## 10.9.7 Example source code for CCITT CRC16 (HDLC)

Example program in Turbo PASCAL:

```

Program CCITT-CRC;
VAR
  crc_table : ARRAY[0..255] OF Word; (* dynamically built up *)
  crc : word;

Procedure CALC_CRC_CCITT( b : Byte);
BEGIN
  crc := ((crc SHR 8) AND $ff) XOR crc_table[ (crc XOR b) AND $ff];
END;

Procedure InitCRC;
Var
  index : Byte;
  j, accu, Data : Word;
BEGIN
  FOR index := 0 TO 255 DO
    BEGIN (* build CRC-table *)
      accu := 0;
      Data := index;
      FOR j := 0 TO 7 DO
        BEGIN
          IF Odd(Data XOR accu) THEN accu := (accu shr 1) XOR $8408
            ELSE accu := (accu shr 1);
          Data := Data shr 1;
        END;
      crc_table[index] := accu;
    END; (* Build table *)
  END;

Begin
  InitCRC;          (* Expand CRC-Table *)

  crc := $ffff;    (* Start-value of the CRC-Register *)
  (* Calculating the CRC follows - for every input-byte
    CALC_CRC_CCITT must be called once. *)

  CALC_CRC_CCITT(04);  (* Give input bytes in decimal here *)
  CALC_CRC_CCITT(01);
  CALC_CRC_CCITT(01);
  CALC_CRC_CCITT(71);

```

## 10 Hostmode

---

```
CALC_CRC_CCITT(71);
```

```
(* and so on.... *)
```

```
CRC:=NOT(CRC); (* CRC is inverted at the end according to HDLC-protocol *)
```

```
(* in WORD CRC is contained the CRC value. When all bytes that should be included in the CRC have been processed, then first one hangs the low-byte from WORD CRC and lastly the high-byte on the Block as "CRC". With the 5 example bytes calculated above, the LOWBYTE=213 and HIGHBYTE=153.
```

When checking the CRC ("reception") one also calculates both the transferred CRC-bytes into the CRC-value. The new CRC value so obtained must equal \$F0B8 if the block has arrived correctly.

Alternatively one can calculate the CRC only using the data bytes, without having to include the CRC bytes. If one inverts the two bytes so calculated, then the result must match up with the two received CRC bytes.)

```
*)
```

End.



## Chapter 11

### 11 PSK31

#### 11.1 General

The PSK31 system developed by Peter Martinez, G3PLX, offers the RTTY enthusiast a modern variation to this by now somewhat old fashioned operating system. It has markedly reduced bandwidth requirements and a better resistance to interference.

The operating technique is very similar to the normal operation of Baudot-RTTY, although a more sensitive fine-tuning is required compared to the older system, as a PSK31 signal requires a tuning accuracy of a few Hertz.

Technically, the system is a differentially phase modulated, single carrier, with a Baud rate of 31.25 steps per second. In practice, DBPSK and DQPSK are employed, but with a heavy leaning towards DBPSK. DQPSK, despite the use of convolutional Coding ( $k = 5$ ), has shown itself to be more prone to errors at very low SNR's compared to uncoded DBPSK. The waveform pulse of PSK31 is the "Raised Cosine in time" so that the DBPSK signal switches between two-tone (when only phase changes are taking place) and a plain single tone carrier. The bandwidth between the first null points of the spectrum is 62.5 Hz. A specialty of PSK31 is that it allows the entire ASCII character set, even the back space" character is included.

#### 11.2 Activation and use of the PSK31 terminal

The command to activate the PSK31 mode is **PSKTerm** in the **cmd:-**menu. Command parameters are not required, and will be ignored if given. After turning on the PSK31 terminal, the PTC-IIpro is in the receive condition. Various PSK31 relevant settings are at their default or previously set values. The **Quit** command closes the PSK31 terminal, and returns to the normal STBY condition. Text input may be carried out whilst in the receive condition, and is placed in the type-ahead buffer. (This can be deleted at any time with <Ctrl-X>.

The alpha-numeric display shows **PSK31 1300**, where the number 1300 is the receive carrier frequency used. (= the center frequency of the audio signal). The tuning indicator takes on a different look. It has been changed to a small *spectroscope*, so that the small band PSK31 signals can be tuned precisely to the correct frequency. Each LED represents the power in a 9.375 Hz wide frequency window. The *spectroscope* encompasses a frequency range of approx. 140 Hz. Lower frequencies are to the right, higher to the left. This is, at first sight, intuitively wrong. It does however make it easier to tune when using the usually clockwise turning VFO control of the modern transceiver. The brighter the LED glows, the higher the energy content within that appropriate window. (refer to chapter 11.7, page 194 on how this display may be used to tune in PSK31 signals)

### 11.3 Carrier Frequencies

The audio carrier frequency for receive and transmit are calculated using the settings for MARK-frequency+SPACE-frequency/2. If one has MARK=1400 Hz and SPACE=1200 Hz, then the carrier frequency is 1300 Hz. A special command for the PSK31 AF-carrier frequency is thus not required. The transceiver connected to the PTC-IIpro can operate with the same settings as for PACTOR or AMTOR etc. The PSK31 carrier, when correctly tuned, lies exactly in the middle of the IF filter passband. When the squelch is open (Hot-key <Ctrl-F>), the PTC-IIpro adjusts the receive carrier frequency slowly (max approx.  $\pm 1$  Hz / 5 sec) automatically. to match that of the received signal. A manual drift correction is not required. Refer also to chapter Hot-keys NET operation.

### 11.4 Level Setting

The PSK31 output level (Transmit level) may be adjusted with the **FSKA**-command. Normally however, the levels previously set for PACTOR/AMTOR operation can be used, as the PSK31 peak power is the same as that produced for FSK operation. As however the amplitude is not constant, the transmitter must on no account be over-driven! otherwise an EXTREMELY wide spectrum is produced.

### 11.5 Prompt and Status

The usual Baudot-RTTY prompt is displayed, except that a P is used as an abbreviation: **\*\*-P-\*\* (SCSP) :>** (here, SCSP is the AMTOR-selcal. This prompt addition is only displayed for compatibility reasons). The expanded command prompt in terminal mode 5 (**TERM** command) has the code **cmd: 5**, or binary 00100101. In the status-byte, refer to **STatus**-command, chapter 6.92, page 104), the PTC displays RTTY/CW as there are no further free codes available here to be used.

### 11.6 Hot-keys

Control of the PSK31 terminal operation is done (as with the CW-terminal, refer to chapter 6.30, page 75) with so-called *Hot-keys*. These are specially defined control codes produced with the <Ctrl>.

**Ctrl-L:** The Receive-carrier frequency is increased by 1 Hz. (Only in the receive condition)

**Ctrl-K:** The Receive-carrier frequency is decreased by 1 Hz. (Only in the receive condition)

**Ctrl-X:** Erases the Transmit (or type-ahead) buffer. (The PTC acknowledges the command with "\*\*\* CLR".

**Ctrl-C:** Switches the squelch between normal operation and continuously open. In normal operation, it is possible for even very weak PSK31 signals to open the squelch. Switching to continuously open (*Garble* on the screen, even when no PSK31 signal is present) should only be necessary in exceptional circumstances.

When the Squelch is open, the tuning indicator displays in addition to the *spectroscope* the actual demodulated PSK31 signal in red. In addition, the Idle, Traffic and Error LED's light up accordingly.

The PTC-IIpro acknowledges the command with “\*\*\* SQUELCH: ON” or “\*\*\* SQUELCH: OFF”. Default value: Squelch in normal condition (=ON).

**Ctrl-N:** Switches the "NET" operation off or on again. This is a PSK31 specific function, which has been developed due to the very small bandwidth, and the therefore essential automatic adjustment of frequency required. NET operation means that **both** the receive and transmit frequencies are automatically adjusted to that of the incoming signal. Even after a long transmitting period there is generally no frequency jump between the QSO partners in question. Manual intervention is thus kept to an absolute minimum during the entire QSO. If both, (or more) QSO partners have NET activated, then it is possible that the entire QSO slowly drifts over the band from over to over, always in the same direction.

If such an effect occurs, then only ONE QSO partner should have NET turned on. With NET non active, the PTC-IIpro adjusts only the receive frequency, and displays this with an exclamation mark in the alpha-numeric display just before the frequency.

In practice it has been found that an activated NET operation gives little or no problems. (A note concerning this can be found in the original G3PLX documentation, available on the internet). The PTC-IIpro acknowledges the command with “\*\*\* NET: ON” or “\*\*\* NET: OFF”. The default setting is NET active.

**Ctrl-F:** Sets the receive and transmit carrier frequency to the default value  $((\text{MARK}+\text{SPACE})/2)$ . This function is only allowed (or possible) in the receive condition. The PTC-IIpro acknowledges the command with “\*\*\* RX/TX-Frequency reset to: 1300 Hz”

**Ctrl-B:** Cycles between the operating modes DBPSK, DQPSK and inverted DQPSK. If a DQPSK variant is chosen, the PTC-IIpro signals this with the DQPSK LED. Inverted DQPSK is needed when lower sideband is used on an SSB transceiver, as here the signal phasors revolve anti-clockwise, and thus build up a false delta-phase association for the values 90 and 270 degrees. If DQPSK is used in LSB, then the inverted DQPSK must be chosen. For USB the normal DQPSK setting must be used (for compatibility with the other PSK31 users).

The PTC acknowledges the command with: “\*\*\* PSK31-Mode: DBPSK” or “\*\*\* PSK31-Mode: DQPSK” or “\*\*\* PSK31-Mode: inverted DQPSK”.

**CHOChr:** Generally <Ctrl-Y>, refer to **CHOChr** command, chapter 6.19, page 69. Serves to switch between receive and transmit.

**QRTChr:** Generally <Ctrl-D, refer to **QRTChr** command, chapter 6.79, page 99. Can also be used instead of **CHOChr** as the final character of a PSK31 transmission.

A PSK31 transmission can be broken off at any time with the **DD**-command. **DD** sets the system back into the normal STBY-mode. The PSK31 receive condition can be left by using the **Disconnect** or **Quit** command. In the PSK31 transmit condition, both these commands act as a normal closedown (identical to the **QRTChr**) of a transmission.

The Hot-keys have priority in the PSK31-terminal mode. This means that no codes should be chosen for the **CHOChr**, **ESCchr** and **QRTChr** being similar to the hot-keys, otherwise the **CHOChr**, **ESCchr** and **QRTChr** will not operate in PSK31 mode

One exception from the rule above is the ESCAPE-character (**ESCchr**). The ESCAPE-character has always priority over the PSK31-hot-keys! This convention ensures that it is always possible to leave the PSK31 mode and return to the command-mode (**cmd:**).

## 11.7 Receiver Tuning

A PSK31 signal can be recognized on the *spectroscope* display by a field of 3-5 brighter green LED's. A PSK31 signal containing only idles (fill-ups without data) consists of a pure two-tone signal with a tone difference of 31.25 Hz. On the tuning display, this sort of signal lights generally only two LED's relatively brightly, with a separation of 3 LED's:

○ ○ ○ ○ ○ ● ○ ○ ○ ● ○ ○ ○ ○ ○ ○

If useful data is being transferred, then a PSK31 signal is shown normally as a band of 3 LED's with heavily fluctuating intensity .

○ ○ ○ ○ ○ ○ ● ● ● ○ ○ ○ ○ ○ ○ ○

To decode a PSK31 signal, it should be as close as possible to the **center** of the spectroscope, i.e. symmetrical, centered around the central (8th) LED. If a PSK31 signal is tuned to within approximately  $\pm 10$  Hz of the middle position with the VFO knob on the transceiver, the squelch opens, and one sees additional red LED's on the tuning indicator which display the actual demodulated PSK31 signal. These can, like in PACTOR-1 or RTTY, be carefully tuned with the VFO until only the two outer LED's (1 and 15) flicker.

● ○ ○ ○ ○ ○ ● ● ● ○ ○ ○ ○ ○ ●

The fine tuning can also be carried out with the hot-keys <Ctrl-K> and <Ctrl-L> if the VFO does not have a fine enough resolution. At first sight, the tuning procedure sounds relatively complex. With a little practice however, the tuning can be carried out almost as easily as with PACTOR-I or RTTY, despite the comparatively small bandwidth of the PSK31 signal. The tuning of DQPSK is however markedly more critical compared to that of DBPSK, and the demodulated (red LED) signals are less clearly defined, so that here one must pay great attention to the *spectroscope*.

## 11.8 CW-Identification

The CWID of the PSK31 terminal always is activated in the *Audio Only* mode, i.e. the PTT is active during the whole time and only the tone signal is keyed according to the rhythm of the CW characters. The special pulse wave shape of the CW character generates a relatively narrow spectrum, so that the adjacent PSK31 channels are not disturbed during the CWID. The PTC-IIpro sends an additional CWID after a PSK31 transmission if the CWID-Parameter (refer to **Cwid**, chapter 6.27, page 74) is higher than 0. If the parameter is higher than 1, also before each PSK31 transmission a CW identification is sent.

## Chapter 12

### 12 SYStest

The system test is not normally required by the PTC user, but has been included here for the sake of completeness. **SYStest** is purely a tool to diagnose and rectify faults in defective PTC's. In normal operation this function is not needed.

The command **SYStest** (without argument) activates the systemtest menu. (**sys:-** menu). The command prompt takes the form **sys:**.

Within the **sys:-** menu, the following systemtest commands are allowed:

**Audio, AUDPerm, BAttery, Beep, DD, Down, Fsk, Help, Kill, Led, MONitor Ptt, PLl, Quit, Ram, SERNum, Trxtest, Up.**

All other (*normal*) commands are not available! The **sys:-** menu may be ended with **Quit** or **DD**.

The **SYStest** command may also be followed by an argument, which should be a command from the **sys:-** menu. In this case, the PTC carries out only that given systemtest command, without switching to the **sys:-** menu. The command may be said to have been fed through.

This command for example would show the PTC-IIpro RAM expansion.

```
cmd: sys Ram <Return>
```

The **sys:-** menu commands in detail:

#### 12.1 Audio

Serves to carry out a so-called *Audio loop test* or check of the analogue I/O stages, as well as the DSP. This function requires a wire connecting PIN 1 (Audio Out) and PIN 4 (Audio In) of the 8 PIN shortwave radio socket (X5)!

If the analogue stages are working correctly, the PTC-IIpro gives out OK. In cases where an error occurs, then NOT OK is displayed.

#### 12.2 AUDPerm

**Default setting: 0**

Parameter: 0 Audio output, only active in the TX operation or the **aud:-** menu.  
1 Audio output permanently activated.

This **AUDPerm** command allows the audio input / received signal to be permanently passed through to the audio output pin, as long as the PTC is in the receive condition. This has the great advantage if one has the PTC-IIpro in use as an AF filter/denoiser:

The received signal is then also connected via the RCU (or home made amplifier) to a speaker, and may be heard independent of being in the **aud:-**menu or not. The speaker connected to the RCU may be used permanently as the stations loudspeaker.

NOTE: With some older or simpler radios, it is possible for feedback to occur when the received signal also appears at the transmitter microphone input. In these unusual cases, the PTC-IIpro must be used with **AUDPerm** set to 0. Alternatively, the transmit AF connection from the PTC to the MIC input may be disconnected. (There is only one D/A converter for both, the transmitted audio and the filtered audio of the denoiser function. These signals are connected in parallel to the RCU control socket as well as to the HF transceiver audio socket.)

### 12.3 BAttery

Checks the internal lithium-battery being for SRAM-backup. When the battery is good then it reports OK, When the battery is weak it reports NOT OK (LOW VOLTAGE!).

### 12.4 Beep

Activates the micro loudspeaker in the PTC-IIpro briefly. With correct operation, a short signal tone should be heard.

### 12.5 DD

Serves to end the **sys:-**menu. The command prompt returns to its *normal* form **cmd:.** Identical to the **quit** command in the **sys:-**menu.

### 12.6 Down

Gives out a 100 ms long key pulse (against ground) at the A0 output of the 8 PIN HF radio socket.

### 12.7 Fsk

Activates the FSK test routine. <Return> toggles between Mark and Space tones. The routine supports the FSK as well as the AFSK outputs. The PTT transistor switch is turned on during the FSK test routine. The FSK test may be ended with <Q>.

### 12.8 Help

Gives a short list of the **sys:-**menu commands. The **Help** command can contain a command word from the **sys:-**menu as argument, whereby a description of that command is given.

Help to the **Audio** command

```
sys: Help Audio <Return>
```

## 12.9 Kill

The sub-directory killer! Enables the stepping through of the PTC mailbox directories in alphabetical order, using the <+> and <->, and removing same with the <#>.

## 12.10 Led

LED test. The PTC-IIpro shows off its *lighting console*.

## 12.11 MONitor

**Default setting: 0**

Parameter: 0 Switches off the Tone Monitor.  
1 Switches on the Tone Monitor.

The *Tone Monitor* should only be used for test purposes. It should not be used on a regular basis. It requires quite a large amount of processing power. This may cause system instabilities! Please disable the *Tone Monitor* after you finished the error diagnosis!

The *Tone Monitor* works as follows:

The tuning display is used as a “spectroscope”, i.e. each tone of the various PACTOR-III waveforms is assigned to a single LED and displayed there: The more error is detected on the corresponding sub-carrier (tone), the more often the corresponding LED flashes red. (If the frequency error still is larger than 15 Hz, also a single green LED flashes during receive gaps.)

Low tones are displayed at the left side of the tuning bar, high tones at the right side. If more than 15 tones are used on a speedlevel (SL 5 and 6), some tones in the center of the spectrum are omitted.

With the aid of the “tone monitor” one can, for example, easily find out whether the receive signal is centered properly within the IF passband, etc. As a rule of thumb any long term asymmetry of the error pattern, e.g. frequent red flickering of the edge LED’s or a higher number of errors at one side of the spectrum, usually indicates a systematic problem on the transceiver side (transmitter or receiver, respectively).

## 12.12 Ptt

Activates the PTT test routine. The PTT switching transistor is toggled on or off by means of <Return>. The PTT test routine can be ended with <Q>.

## 12.13 PLI

Tests the DSP PLL. With correct operation of the PLL, the PTC-IIpro gives OK. In case of error, NOT OK is given.

### 12.14 Ram

Displays the measured RAM available in the PTC-IIpro.

### 12.15 SERNum

**SERNum** displays the serial number of the PTC-IIpro. This number always has 16 digits.

**SERNum** answers as follows:

Serial number: 01000005A6E69C22

### 12.16 Up

Gives out a 100 ms long key pulse (against ground) at the A1 output of the 8 PIN HF radio socket.

### 12.17 Quit

Exits the **sys:-**menu. The command prompt returns to its *normal* form (**cmd:**). Identical to the **DD** command of the **sys:-**menu.

### 12.18 Trxtest

Tests the transceiver control port. This command is only working properly when using a special test adapter on the TRX-control connector.

## Chapter 13

### 13 TRX

The **TRX** -command (without argument) activates the transceiver remote control menu (**trx:-menu**). The command prompt takes the form **trx:**. The following commands are allowed within the **trx:-menu**:

**Channel, DD, Down, DUmP, DWell, Frequency, Help, List, Offset, Ptime, RType, Scan, TImeR, Transfer, TYPe, Up, Quit, Wait, XGate, XScan and YType.**

All other (*normal*) commands are not available from within the **trx:-menu**. The **trx:-menu** may be closed either with **DD** or **Quit**.

The **TRX** -command may also contain an argument, this being a suitable command from the **trx:-menu**. In this case the PTC will then carry out this command, without switching to the **trx:-menu**. The control command may be said to be fed through.

Example:

This command, for example, would change the frequency of a connected transceiver directly to 14079.0 kHz - without having to divert to the **trx:-menu**.

**cmd: TRX Frequency 14079.0 <Return>**

The **trx:-menu** commands in detail:

#### 13.1 Channel

The PTC allows up to 32 channels to be defined. Every channel consists of a channel number, its frequency (in kHz), the scan status, the Gate status and an optional short info text. For example:

CHANNEL-LIST:

=====

Ch	Frequency (kHz)	Scan	Gate	Comment
1:	3583.650	YES	NO	dl1zam channel 1
2:	3585.650	YES	NO	DL1ZAM channel 2
3:	3584.000	YES	YES	Test QRG DL1ZAM
4:	14079.000	NO	YES	DL2FAK CN2SM
5:	14076.540	NO	NO	EA5FIN's summer QRG
6:	14075.600	NO	YES	LA2MV
7:	14080.000	NO	YES	9K2EC special
8:	3587.000	YES	YES	SM3HUA QRG
9:	3595.400	NO	YES	DJ9YJ QRG
10:	3588.000	NO	YES	DK0MAV HB9AK
11:	14077.000	NO	YES	second ch dl2fak

The **Channel** command (without argument) behaves exactly as a **List** command for the **TRX** command set. All user defined channels are listed.

If the **Channel** command is followed by ONE argument, consisting of a number between 1 and 32, then the PTC switches the connected TRX to the given channel frequency.

If the command

```
trx: Ch 3 <Return>
```

is given, then (from the above list) the TRX would be switched to 3584.000 kHz, if channel 3 is set to this frequency.

The definition of a channel is carried out by putting two or three arguments after the Channel command.

```
trx: Ch 11 14077.0 second ch d12fak <Return>
```

The length of the comment must not exceed 52 characters. As the comment does not contain essential information, it may be omitted. The frequency input is always in kHz, where however the decimal point after the Megahertz position is optionally allowed (e.g. 14,076.54). The last decimal point is processed as a kilohertz decimal point. There are up to three positions allowed after this decimal point, whereby a frequency accuracy of 1 Hz has been anticipated (which cannot be used by some TRX's as only 10 Hz synthesizers are used).

Valid Frequency inputs:

```
14079
14079.0
14079.010
3,582.500
1000.123
```

The frequency input 0 kHz serves to erase the channel from the frequency list.

Deletes the channel 1 from the frequency list

```
trx: Ch 1 0 <Return>.
```

The comment field has several purposes, one is certainly is to act as a reminder. But the same time the comment field can be used to specify additional channel properties, so called attributes. A detailed description can be found in section [13.25](#) on page [211](#).

The maximum length of the comment field is 52 characters.

## 13.2 DD

Serves to leave the **trx:-**menu. The command prompt changes back to its *normal* form (**cmd:**).

### 13.3 Down

#### Default setting: 1

Parameter: X 1... 60,000, number of pulses

Creates a definable number of low-pulses on the A1 output, pin 6 of the 8-pin HF-transceiver connector.

In earlier times this output was made to control the “down” key at the transceivers microphone, but this application has turned out to be not practicable.

The actual firmware uses this output to control an external antenna switch, refer to chapter [13.25](#) on page [211](#).

### 13.4 DUMP

#### Default setting: 0

Parameter: 0 Dump mode disabled.  
1 Dump mode enabled.

With the command **Dump** 1 <Return>, the PTC-IIpro is switched to transceiver dump mode, this mode providing a very simple Host mode for direct communication between the terminal program and the transceiver. The PTC-IIpro only serves as a level converter or baudrate converter, and delivers, as required, the necessary signal preamble (for SGC transceivers), but the actual control sequences must be delivered by the host computer, or terminal program. In dump mode, the information given out by the transceiver is transferred direct to the host computer, and must be processed there.

TRX dump sequences from the host computer (terminal) to the PTC-IIpro have the same format as the TRX dump sequences from the PTC-IIpro to the host computer, these consisting of:

1. TRX dump header, for unambiguous recognition of the TRX dump sequences.
2. The actual data field, in hexadecimal form, (identical to the data field when using the Transfer command for SGC, ICOM and YAESU).
3. The end character, CR, (ASCII 13).

Dump sequences always begin with the TRX dump header, this header consisting of the following; <Ctrl-E><#><T><X><:;>, where <..> denotes in each case one byte (ASCII), corresponding to 05H 23H 54H 58H 3AH.

The header is only then valid when it appears complete. If, for example, the third header byte is defective, then the PTC-IIpro behaves as if the Ctrl-E start character is an accidental Ctrl-E, or an actual Ctrl-E that has not been input as a TRX control character, the PTC-IIpro then sending the buffered characters of the intended dump header into the normal command interpreter or transmit buffer.

If one types, for example, Ctrl-E#TXXX, during an actual PACTOR link, then these characters would be transmitted over the HF link, and would not be transferred to the transceiver.

A restrictive processing of the header allows through transfer of transceiver sequences, WITHOUT, in practice, limiting the data transparency, the danger of a piece of text being *swallowed*, due to an accidental Ctrl-E is virtually 0.

The host computer, or terminal program, should, naturally also thoroughly check the transferred TRX dump sequence, and a "defective" header should be fed back into the normal process, (e.g. output as text in the receive window).

The dump header can be followed by up to 256 bytes (or 512 places) of actual transfer information in hexadecimal form, spaces in this data field being ignored, and if an uneven number of hexadecimal places (nibbles) are given, then the PTC-IIpro ignores the last nibble.

A TRX dump sequence is always closed with an ASCII 13 (carriage return), although this last character is not transferred to the transceiver by the PTC-IIpro, and the TRX dump sequences from the PTC-IIpro to the host computer are also closed with ASCII 13.

Example:

The control sequence FA; should be sent directly to a KENWOOD transceiver via TRX dump. The ASCII character string for this is:

```
<Ctrl-E>#TX:46413B<CR>
```

Here, the <.> symbolizes an ASCII special character, CR = carriage return, and the transceiver answers this command in its turn with a longer sequence, which the PTC-IIpro passes directly as a TRX dump to the terminal.

**IMPORTANT:** Some Transceivers (e.g. KENWOOD TS-450) ONLY accept remote control commands in the receive condition. The terminal must take this into consideration, in that (for example), during the linked state, each of the following acknowledgments are checked to see if the command has been accepted by the transceiver. If not, then the command must be repeated after approx. 100 msec, etc. (Possibly with timeout and error message displays).

Timing of the TRX dump sequences:

Dump sequences to the transceiver are sent a few milliseconds after the closing <CR>, as a continuous string, without pauses (idles).

Sequences from the transceiver are transferred, via the PTC-IIpro, to the terminal as dump sequences when...

1. With KENWOOD or ICOM Transceivers, the appropriate end character (delimiter) is recognized.
2. The string length reaches 40 characters. That means that the maximum info length of the TRX dump from the PTC-IIpro to the terminal is 40 bytes, although with YAESU transceivers the maximum string length is restricted to 19 bytes.

3. If no further information is received from the transceiver for longer than 40 byte lengths, and information from the TRX is available. (For SGC transceivers this idle timeout has been reduced to 20 byte lengths).

There is only a few milliseconds delay between the recognition of the end condition, and the beginning of the dump sequence,

**Important Note:**

Ctrl-E should no longer be used as *Hot-key*, e.g., as changeover or QRT key, when the dump mode is activated. If, however, the Ctrl-E should be defined as a control character, then the PTC-IIpro will not give an error message, the processing of the Ctrl-E as *Hot-key* being delayed when the dump mode is active, for a minimum of one character, and the respective following characters are checked, to see if they are valid for the TRX dump header, in other words, a buffering taking place.

The Frequency command in the **trx:-**menu, (without argument), requests the output of the TRX frequency, but with an active dump mode, these transceiver outputs caused by the **F** command are also shown as dump sequences, and no longer as a decimal ASCII string. The **F** command in this case, then also gives a TRX dump sequence. (This is, however, not the case in remote control access, when the dump mode is ignored).

### 13.5 DWell

**Default setting: 30**

Parameter: X 5... 1,000, dwell time in 100 ms.

**DWell** sets the dwell time of the PTC scanner on each channel in 100 ms steps. A **DWell** time of 30 means, for example, that the scanner will pause on each channel for exactly 3 seconds.

### 13.6 Frequency

**Default setting: NONE**

Parameter: X Frequency data.

Allows the direct setting of the TRX frequency, without having to define a scan channel. The format is, however, that as described in the **Channel** command.

Without a parameter the Frequency command returns the current operating frequency from the transceiver.

If a beep is heard during frequency input or scanning, that's not the PTC-IIpro, that's the transceiver. Refer to the transceiver manual to switch off the confirmation beep!

## 13.7 Help

Gives a short list of the commands used in the **trx:-**menu. The **Help** command may also contain a command word from the **trx:-**menu as argument, whereby a description of that command is given.

Special information to the **Channel** command

**trx: Help** Channel <Return>

## 13.8 List (remotable as command TRX List)

Lists the entire defined PTC frequency list. Refer also to the **Channel** command, chapter [13.1](#)

## 13.9 Offset

**Default setting: 0**

Parameter: X -5,000... 5,000, offset in kHz.

Frequency format as for the **Channel** command

The Offset value is applied to **every** frequency (Channel list, Frequency command etc). before it is output to the transceiver.

This allows, even whilst in SSB mode, the transceiver to be set to the Mark frequency of the PTC of the other station. If, for instance, Low tones are being used (1200/1400 Hz **TONes-Parameter=0**) and USB, then the TRX is set on 14077.60 kHz in order to transmit the Mark frequency of 14079.00 kHz. As the transceiver displays the frequency of the (imaginary) carrier, then, in USB, the frequency of the audio Mark tone (1400 Hz) must be added to the carrier frequency, for the actual Mark frequency to be calculated. If on the other hand, the Mark frequency is taken from a BBS list, the Mark tone frequency must be subtracted, in order to find the correct frequency to tune the SSB transceiver to. If the Offset value is defined as 1.4 kHz, the PTC-IIpro does the required frequency correction for the Mark frequency automatically. It is thus only necessary to give the wanted Mark frequency, and the correct offset is automatically applied. For example, one can give the command "Frequency 14079.0 <Return>". The PTC-IIpro then sets the transceiver to 14077.6 kHz, which automatically, with Low tones and USB, gives the correct transmit and receive frequency of 14079.0 kHz. Similarly with LSB (only here the positive Space tone frequency would be chosen as Offset) and with different tone pair frequencies.

## 13.10 Parity

**Default setting: 0**

Parameter: 0 No parity bit (default).

Parameter: 1 Odd parity

Parameter: 2 Even parity

Some transceiver types require a data format with parity bit for communication on their remote control port. The **Parity** command provides the possibility of inserting a parity bit at the end of every transferred byte on the trx control port. The **Parity** parameter only affects the “Kenwood” data format (i.e. **Type** must be set to “Kenwood”, see **Type** command in **trx:-menu**).

### 13.11 Ptime

**Default setting: 50**

Parameter: X 1... 1,000 pulse time in milliseconds.

Sets the time (in Milliseconds) for the Up and Down keying pulse, that can be initiated from the **Up** and **Down** commands (**trx:-menu**). A **Ptime** value of 50 means that the respective switch in the PTC-IIpro per impulse is closed for 50 ms and open for 50 ms.

### 13.12 Quit

Serves to leave the **trx:-menu**. The command prompt returns to its *normal* form. Identical to the **DD** command in the **trx:-menu**.

### 13.13 RType

**Default setting: 0**

Parameter: 0 R&S XK-2000.  
1 R&S XK-852.

As default setting the PTC-IIpro supports the R&S model XK-2000. If **RType** is set to 1 than the PTC-IIpro does support the R&S transceiver model XK-852 for remote control. The VFO information readout is currently *not* possible in this configuration.

This command is only active, if R&S as transceiver is selected with the **Type** command.

### 13.14 Scan

**Default setting: 0**

Parameter: 0 Stop scanner.  
1 Start scanner.  
C 1... 32, toggle channel scan status.

The **scan** command has two different functions: If, as argument, a 1 or 0 follows, then that means the scanner is switched on or off respectively. This can be said to be the *main switch* for the scanner.

If, as argument, the word Channel (Minimum abbreviation: C) follows, then the PTC requires a further argument the Channel number from the frequency list (refer to the

**Channel** command, chapter 13.1, page 199). Such a command switches the Scan status for the given channel number. If the Channel 5 of the frequency list has not been defined as a scanned channel up until now (Scan-Status: NO), then it may be declared as such with the command Scan Ch 5 <Return>. Through this command, Channel 5 then obtains the Scan Status YES in the frequency list. A new input of the command Scan Ch 5 <Return> toggles the Scan status back to NO, whereby Channel 5 would be skipped again on scanning.

If a beep is heard during frequency input or scanning, that's not the PTC-IIpro, that's the transceiver. Refer to the transceiver manual to switch off the beep for confirmation!

### 13.15 TIme

It is possible to define 10 timers (Timer number, length of time with start and stop times). Each time "window" can be taken as an individual timer, and thus in the following text, the words time "window" and timer are synonymous.

There are various input formats possible:

```
trx: TI 1 4:00-5:00 <Return>
trx: TI 5 0700 0930 <Return>
trx: TI 2 23:00-3:00 <Return>.
```

The first argument is the number of the timer (0 to 9) that one wishes to view or change. The second is the time period in hours and minutes indicating the start and stop times. The "end" time can also be earlier than the "start" time, which means the timer remains active through midnight and into the next day.

It is essential that hours **and** minutes are given, i.e. at least three places e.g. 300-400 for the period 3:00 to 4:00. The hyphen between the start and stop times is optional and can be replaced with a space. Leading zeros are also optional.

If the **TIme** command is given without arguments, then the PTC lists the entire timer table. If only the timer number is given as argument, then the PTC-IIpro shows the times defined for only this timer.

A single hyphen as a timer period erases the timer.E.g.:

```
trx: TI 1 - <Return>
```

### 13.16 Transfer

The command **Transfer** allows any character sequences to be sent via the normal command interpreter of the PTC-IIpro to a connected transceiver.

If the transceiver type has been set to KENWOOD, then ASCII characters can directly follow the **Transfer** command, as KENWOOD transceivers work directly with ASCII sequences. The Transfer sequence is closed with <Return>.

Commands the KENWOOD transceiver to switch to VFO A, and to return the frequency of the VFO A.

```
trx: T FA; <Return>
```

In the case of transceiver types SGC, YAESU, or ICOM, the transfer sequences must be given in hexadecimal form.

Example:

Commands the SG 2000 to switch to the next operating mode ('step radio mode' command).

**trx: T F18A8A <Return>**

With the hexadecimal input spaces are ignored, and both upper and lower case letters are allowed.

Transfer sequences may be easily stored as Fixtext or Fixfiles, for individual control of transceivers.

### 13.17 TType

**Default setting: ICOM 1200 04**

Parameter: X ICOM / KENWOOD / R&S / SGC / YAESU  
Baudrate (1200 – 115200 Bd)  
ICOM ID / VFO (A/B)  
V24/TTL

Enables the configuration of the PTC-IIpro TRX interface. There are up to three arguments allowed.

The first argument indicates the transceiver, the following transceiver are supported:

- ICOM
- KENWOOD
- R&S Rhode & Schwarz
- SGC
- YAESU

The first letter is sufficient.

Then follows as the second argument, the baudrate. The PTC-IIpro supports the following values: 1200, 1800, 2400, 3600, 4800, 7200, 9600, 12000, 14400, 16800, 19200, 28800, 38400, 57600, 76800, 115200.

For the third argument differs depending on the selected transceiver type:

ICOM

The PTC requires the ICOM equipment address number. The address can be entered decimal (0 to 255) or hexadecimal (\$0 to \$FF). If entered hexadecimal the \$ has to be entered first, same for \$F0 or \$6C. Leading zeros are suppressed.

In manuals you sometimes will find the following expression: e.g. 4Eh. The small h indicates that the value is a hex number. (But smarty pants would have recognized this

before. The marking usually is not necessary, because an E is never part of a decimal number!). The PTC-IIpro expects the input \$4E, i.e., the h is not given!

KENWOOD and YAESU

The VFO (A or B) that should be addressed by the PTC. With SGC and R&S the third parameter is obsolete.

The following restrictions have to be cared of for R&S:

Data from the receiver is not reformatted by the PTC-IIpro, but simply fed through directly to the terminal. For the **Frequency** command without argument not the offset corrected frequency in kHz will be displayed, but the original string from the transceiver.

The fourth argument defines if the transceiver is controlled with TTL or V24 levels. Refer to the transceivers manual to determine if it requires TTL or V24 levels.

If your transceiver has a 9-pole SUD-D connector for remote-control then it's most probable that it uses V24 levels.

Commands for different transceivers:

**trx: TY I 1200 4** <Return>

**trx: TY I 1200 \$1C** <Return>

**trx: TY K 4800 A** <Return>

**trx: TY K 4800 A V** <Return>

**trx: TY Y 9600 B** <Return>

**trx: TY S 9600** <Return>

If less than four arguments are given, the PTC-IIpro only changes the explicitly given parameters. The command **TY I 9600** <Return> for example sets only the type to ICOM and the baudrate to 9600 Bd. The equipment address remains unchanged.

## 13.18 Up

**Default setting: 1**

Parameter: X 1... 60,000, number of pulses.

Creates a definable number of low-pulses on the A0 output, pin 8 of the 8-pin HF-transceiver connector.

In earlier times this output was made to control the “down” key at the transceivers microphone, but this application has turned out to be not practicable.

The actual firmware uses this output to control an external antenna switch, refer to chapter [13.25](#) on page [211](#).

### 13.19 Wait

**Default setting: 10**

Parameter: X 1... 240, time in seconds.

Defines the time (in seconds) that the scanner waits after the end of a link, before it switches to the next channel. The waiting time for the re-synchronization of AMTOR is not influenced, as the phasing condition in AMTOR ARQ is interpreted internally within the PTC as a continuous connect, and the scanner therefore remains switched off.

### 13.20 XGate

**Default setting: none**

Parameter: X Channel number 1... 32  
S Switch 0 or 1

**XGate** allows the Gate parameter to be set for a channel defined within the TRX list.

Set Gate parameter of channel 5 to YES.

```
trx: xG 5 1 <Return>
```

Set Gate parameter of channel 10 to NO.

```
trx: xG 10 0 <Return>
```

If a channel has been defined new with the **Channel** command, the Gate parameter is defaultly set to NO. If the PR->PACTOR gateway operation shall be enabled, the **XGate** command has to be used once for each admitted channel.

### 13.21 XScan

**Default setting: none**

Parameter: X Channel number 1... 32  
S Switch 0 or 1

The **XScan** command allows the Scan parameter to be set for a channel defined within the TRX list.

As an alternative to the previous scan enabling possibility of two arguments (e.g. S C 5), that *toggled* (switched) the scan function on or off, the **XScan** command allows particularly channel scan definition:

Set Scan parameter of channel 10 to NO.

```
trx: xS 10 0 <Return>
```

Set Scan parameter of channel 4 to YES.

```
trx: xS 4 1 <Return>
```

The **xScan** command is particularly useful in the initialization/configuration file of the PTC-IIpro, because a new defined state can be set without knowing the current state of the scan parameter.

## 13.22 YType

**Default setting: 0**

Parameter:	0	YAESU Type FT-890
	1	YAESU Type FT-990/FT-1000
	2	YAESU Type FT-1000 MP
	3	YAESU Type FT-100
	4	YAESU Type FT-920
	5	YAESU Type FT-847
	6	YAESU Type FT-817/FT-857/FT-897

Specifies a special YAESU transceiver as sub-type to enable the PTC-IIpro to readback the frequency from the transceiver. This command is only effective, if a YAESU transceiver has been selected with the **T**ype command.

## 13.23 External scan stop signal

The PTC-IIpro offers an external scan stop signal via its RS232 interface, on which TRX control programs in the larger mailbox systems (e.g. WINLINK) can react. PIN 1 (CD) of the SUB-D-9 socket delivers a negative level (approx. -8 to -10 V) as long as no scan stop conditions are available, i.e. the external scanner may change the RX frequency. PIN 1 (CD) of the SUB-D-9 socket delivers a positive level (approx. +8 to +10 V) as soon as a scan stop condition is detected, i.e. the external scanner must hold the RX frequency constant.

**IMPORTANT:** After the link has been closed, or the reason for the scan stop condition has ended, the scan-stop signal (positive CD level) remains for a time which may be adjusted by the WAIT-TIME command (**wait** command) within the **trx**-menu. The scan stop condition reaction timing is that of the SYNCH-Status (status byte), and thus reacts even to incomplete callsigns for a connect, and is thus extremely fast.

## 13.24 Special Features

### 13.24.1 Direct Channel Selection for YAESU Transceivers

If as a TRX type YAESU is selected, the frequencies (also in the channel and scanner list of the PTC-IIpro) smaller than 100 Hz (e.g. 0.099 kHz) are interpreted as channel numbers. In this case not a frequency string is sent to the TRX (for **F**-command or while scanning), but the *Recall Memory* command, that means a channel preset in the TRX itself is selected. This has the advantage that filter settings and sideband information etc. are additionally stored in the TRX and therefore under control of the PTC-IIpro.

## 13.25 Channel attributes

The desired channel attribute must be given when setting up the (scan) channel list, in the comment field. Here for example it is possible to define at which time the channel shall be *active* and which antennae shall be chosen for the channel.

The way one goes about defining a channel command (in the **trx**:-menu) is explained in the **Channel** command description (refer to section 13.1 on page 199). Here is a short example of how one could define channel 1:

```
trx: c 1 3584.00 COMMENT ...<Return>
```

In order that the channel attribute becomes operative, the scanner (**Sscan** command) must be turned on and the appropriate channel must have its scan status set to ON (**xs** command).

The characters #: (hash and colon without a space) are used in order to separate the scan attribute from the "normal" comment in the channel comment field. There can be multiple channel attributes after such a character string. Multiple #: characters in a comment field are also allowed. (This is required for example with Rhode and Schwarz specific V0/1 channel attributes, which must always follow directly after its own #: string.) The number of channel attributes is only limited by the length of the comment field (52 characters). A space indicates the end of a channel attribute chain.

What attributes are possible, follows in the next sections. For example however here are some possible comment fields with channel attribute chains.

```
trx: c 1 3584.00 #:a0t3t4 #:V0 <Return>
trx: c 2 14079.00 DL6MAA #:A2T3P6 <Return>
trx: c 3 3584.24 #:P3P2T6A1 DL3FCJ <Return>
trx: c 4 3584.00 #:t1 <Return>
```

Either capitals or small letters may be used for the attribute.

### 13.25.1 Preamp switching at R&S XK-2000 Transceiver

When frequency information is sent to the XK-2000 transceiver (be it directly given with the **F**-command or automatically by the channel list), the PTC-IIpro automatically switches on the transceiver's preamplifier on frequencies above 20 MHz and off at frequencies below 20 MHz. This automatism can be overridden by the channel attributes #:V0 and #:V1 in the comment field of the channel list. That means, when the sequence #:V0 appears in the comment field, the preamplifier is always disabled for the respective channel. With the sequence #:V1 it is always enabled, independent on the frequency the channel specifies.

### 13.25.2 Controlling the Antenna Switch

The **A** attribute serves to choose one from four possible antennas with an external antenna relay. Format: **A** followed by a number in the range 0 to 3. The number defines which antenna should be activated. The output is the open drain output for "A0" (Pin 8) and

"A1" (Pin 6) of the 8 pin radio port socket. The number 0 to 3 may be described in binary using two bits: 0=00, 1=01, 2=10, 3=11. The righthand bit is the lowest value bit and controls the A0 output. The left bit controls the A1 output. The outputs are low resistance when the controlling bit is set to 1. This all sounds relatively complex, but in practice is very easy.

Antenna number	A1 output conducts	A0 output conducts
0	No	No
1	No	Yes
2	Yes	No
3	Yes	Yes

Table 13.1: Antenna Switch Conditions

Either a small 2 bit decoder circuit can be connected, or a maximum of two relays may be connected DIRECTLY to the A0 and A1 outputs.

The relay current must not exceed 100 mA, and the voltage should not exceed 15 volts!

To switch between two antennas it is enough to connect an antenna relay directly to the A1 output and supply the relay with (e.g.) 12 volts. (don't forget to connect GND). The Antenna attribute A0 keeps the relay unenergised. Antenna attribute A1 energises the relay, (single changeover contact) and switches a different antenna to the transceiver.

An antenna attribute of A0 to A3 can also appear as argument in a frequency command, after the actual frequency input:

```
trx: F 14000 A0 <Return>
```

This sets the transceiver to 14,000 MHz and also activates antenna 0. This "feature" may be used with FFB scripts. The #: string is not for direct input of the antenna attributes.

### 13.25.3 Timer Attributes

The timer attributes T and P use the timer "windows" defined with the **TImeR** command. If a T attribute appears in a channel comment field, then this channel would only be actually chosen in a scan operation, when the actual time is within the time "window" defined by the T attribute. Is this not the case the channel is skipped. E.g.:

One sets the timer 0 with the **TImeR** command to a time span of 14:00 to 15:00 (Command **TI** 0 14:00-15:00 <Enter>). The attribute #:T0 then limits the "active" time of a scan channel to 14:00 to 15:00. If no further **TImeR** attributes are given for this channel, then the channel is only scanned between 14:00 and 15:00. At all other times, the channel is skipped. Multiple, even overlapping **T** attributes are possible, enabling a very flexible time control of various functions. E.g.: #:T3T2T7P0.

Everything written for timer attribute **T** is also valid for timer attribute **P**, except the **P** attribute concerns **PRIORITTY** times. This means that during an active **P** time "window" the scanner stays **ONLY** on this **ONE** channel, and does not scan! With the given

example of timer 0, an attribute #:P0 in a channel attribute would mean that between 14:00 and 15:00 the system would sit on that channel. It is therefore best to be careful with the **P** attribute, so that the scanner is not mistakenly disabled. The **P** attribute also allows cascading and overlapping. The **P** attribute is however very suitable for use with timecontrolled NAVTEX reception.

If the **T** or **P** attributes are used for a non-defined **TIme** number, then the PTC-IIpro just ignores them.

### 13.25.4 Hex Attribute

We recommend that only experienced PTC users utilize the #:h attribute because improper usage can cause a general malfunction of the transceiver remote control.

With the aid of the new channel attribute #:h arbitrary binary data can be transferred to the transceiver through the TRX port. For example, a different IF filter bandwidth can be assigned to each scan channel and thus automatically be changed during scanning. Changing the bandwidth is useful when narrow (“PACTOR-II only”) channels and wideband channels are supported simultaneously.

The binary data must be appended directly to the h attribute in hexa-decimal format. All hex nibbles (represented by characters 0-9/A-F/a-f) are grouped to bytes (MS nibble first) when the PTC processes the hex string and then transmitted to the transceiver in binary format.

If the number of nibbles is odd, the last nibble will be ignored.

Each character which cannot represent a hex nibble can be used as “delimiter” (end of string indicator), e.g. the letters T and P. Hence, channel attributes T (timer) and P (priority timer) can directly be appended to the hex string without inserting an additional delimiter. If an A attribute directly follows the hex string, a delimiter must be inserted, e.g. a space character, see example.

```
trx: c 1 3584.00 #:h0000c3540c a1 <Return>
```

### 13.25.5 Level Attribute

With the Level Attribute L2 (# :L2) a channel can be limited to PACTOR-I/II operation only. This can be used if on the dedicated channel PACTOR-III transmissions are not wanted e.g. because of bandwidth issues.

```
trx: c 2 14079.00 DL3FCJ #:L2 <Return>
```

## 13.26 TRX Control Channel on Hostmode

Virtual hostmode channel 253 serves as transparent data channel between PC and TRX port. Arbitrary data can be exchanged between PC and transceiver on channel 253. This enables, for example, direct transceiver remote control from the PC side. There is one length limitation: If more than 1000 bytes of data sent from the transceiver are already buffered, the PTC does not accept more data until the buffer is flushed (data fetched by the PC application).



## Chapter 14

### 14 The BIOS

The internal operating software of the PTC-IIpro is divided into two major parts:

**Firmware:** Operating software available to the user, which supports, for example, PACTOR, AMTOR, RTTY, etc, including the command interpreter and multitasking. and for which an update is occasionally available, to provide additional, and improve, current features. These updates are readily loaded into the PTC-IIpro using **UPDATE.EXE** or **PlusTerm**.

**BIOS:** Basic Input Output System, which is the kernel operating system that the user normally does not need to access.

The BIOS allows some of the basic functions of the PTC system to be used and works totally independently from the presently loaded firmware. The BIOS has a very basic and essential task, and is thus placed in a specially protected area of the FLASH memory.

Normally, the user does not need to worry about the existence of the BIOS. However due to various unlucky or exceptional circumstances, it is possible that the PTC-IIpro will no longer load the PACTOR firmware. Under these conditions, it is only possible to access the PTC-IIpro via the BIOS.

If, for example, there is a power failure during a normal firmware update, one part of the FLASH is programmed with the new version, while the other still contains a part of the old firmware. It is very unlikely that such a mixture will run, and the BIOS is then the only way that the update can be repeated.

The BIOS is automatically activated as soon as the PTC-IIpro detects an error on loading the PACTOR firmware, or the user wishes access to the BIOS.

#### 14.1 BIOS and Firmware

What happens after switching on the PTC-IIpro?

The following lines explain the behavior of BIOS and firmware of the PTC-IIpro to interested users.

First of all the BIOS controls the PTC-IIpro. After BIOS has been successfully started it initiates the LED's, the serial interface, the RAM and the other peripherals. In the meantime the BIOS performs a light-show as a sign of life. Next of all it is checked if the user wants to activate the BIOS. In this case the command interpreter of the BIOS is activated and the commands described in the following chapters are available. The PTC-IIpro indicates **BIOS 1.58** in the display.

The BIOS checks if a firmware is loaded properly into the RAM by using a signature. If a firmware is detected a checksum is calculated over the program codes and checked for validity. If this test is positive then the firmware in the RAM is started directly.

If one of the two tests mentioned before is negative, the firmware has to be loaded from the Flash-ROM into the RAM. This procedure has two reasons. The first is that the

firmware is contained by the Flash-ROM only in compressed form and the second is that Flash-ROM has only 8 bit data-bus width. Within the RAM 32 bit are available so that the firmware runs significantly faster.

The loading takes some time and is displayed within the LED display with **loading**. After unpacking and loading the firmware the BIOS has finished its job and now the firmware is responsible for controlling the PTC-IIpro.

### 14.2 Activating the BIOS

As the PTC-IIpro has no switches to let the user express the intention to operate it with the BIOS a special procedure is used to activate the BIOS.

The PTC-IIpro performs a LED test when powered on. This test has 2 phases, first the LED's are red and afterwards they appear green. When the PTC-IIpro is switched OFF again whilst performing the LED-test, then at next power up it will come with the BIOS. Being in the BIOS the PTC-IIpro indicates by indicating **BIOS 1.90** in the display.

The BIOS can be terminated by switching the unit OFF again. This can also be done with the OFF command of the BIOS (refer to [14.3.5](#) on page [217](#)). At next power-on it will start the firmware again.

### 14.3 BIOS commands

#### 14.3.1 DAte

**Default setting: none**

Parameter: DD.MM.YY Desired date.

Identical to the **DAte** command in the PACTOR firmware.

**DAte** is used to set or read the PTC calendar. If **DAte** is entered without a parameter, the PTC-IIpro displays the current date. All positions have to be entered. Leading zeros must not be omitted. The hyphen for separation are not necessary. Faulty inputs cause incorrect programming of the clock chip!

From 01.01.1990 up to 31.12.2089, the day of the week is automatically calculated from the date. Thus your PTC-IIpro is well equipped for the future!

Required date Sunday 24th March 1991.

**cmd: DA** 24.03.91 <Return>

Or in shortform

**cmd: DA** 240391 <Return>

### 14.3.2 FCall

**Default setting: none**

Parameter: CALL           Flash call, max. 8 characters.

Checking and setting of the flash call. By using the **FCall** command, it is possible to store your own callsign permanently in FLASH ROM.

Stores the flash call DL3FCJ

**cmd: FC DL3FCJ <Return>**

Checking the flash call.

**cmd: FC <Return>**

The flash call is used as default callsign by the PACTOR firmware after a **REStart**.

### 14.3.3 FSelcall

**Default setting:  
none**

Parameter: SELCALL       Flash-Selcall, max. 4 characters

Checking and setting of the flash selcall. By using the **FSelcall** command, it is possible to store your own selcall permanently in FLASH ROM.

Stores the flash selcall DFCJ

**cmd: FS DFCJ <Return>**

Checking the flash selcall.

**cmd: FS <Return>**

The flash selcall is used as default selcall by the PACTOR firmware after a **REStart**.

### 14.3.4 Help

Displays all useable commands. It is also possible to obtain further help on a command whilst in BIOS with Help <CMD>.

More details to the **SERbaud** command

**cmd: Help SERBaud <Return>**

or shortened to:

**cmd: H SERB <Return>**

### 14.3.5 OFF

Switches off the PTC-IIpro. With signals on the RS232 link the (e.g. one or more <return>) it switches on again.

In *off-by-command* condition the PTT-LED of the packet-radio port 2 is blinking.

### 14.3.6 SERBaud

#### Default setting: auto

Parameter: baudrate The serial interface of the PTC-IIpro is pre-set to the given baud rate.  
auto Automatic baud rate recognition.

Identical to the **SERBaud** command in the PACTOR firmware.

Sometimes it is obvious to avoid the automatically baud rate recognition of the PTC-IIpro. This is for example is the case if the PTC-IIpro (the whole station) is switched on and off by a timer. Also if you want to react the PTC-IIpro on a hostmode program after switching on you have to set the baudrate to a fixed value.

The **SERBaud** command allows the PTC-IIpro to be set to a certain baud rate and to avoid the automatic baud rate recognition after switching on the PTC-IIpro. The PTC-IIpro doesn't display AUTOBAUD / press CR, but will start directly!

To set the baud rate to 9600, just enter the following command:

**cmd: SERB 9600** <Return>

Switching on the PTC-IIpro the next time 9600 baud will be displayed!

To activate the automatic baud rate recognition again enter the following command:

**cmd: SERB auto** <Return>

Switching on the PTC-IIpro the next time the automatic baud rate recognition will work.

Without entering arguments the **SERBaud** command shows the actual baud rate. The message "auto" will be added if the automatic baud rate recognition is turned on.

### 14.3.7 SYStest

Switches to the **SYStest** commands. The command prompt changes from **cmd:** to **sys:.**

### 14.3.8 Time

#### Default setting: none

Parameter: HH:MM:SS Desired time.

Identical to the **TIme** command in the PACTOR firmware

Arguments are ignored during remote control.

**TIme** is used to set or read the internal clock.

If **TIme** is entered without a parameter, the current time is displayed.

When the clock is set, leading zeroes must not be omitted. The colons can be omitted. Wrong entries cause a wrong programming of the clock component.

**cmd: TI 09:56:05 <Return>**

or

**cmd: TI 095605 <Return>**

### **14.3.9 UPDATE**

Identical to the **UPDATE** command in the PACTOR firmware.

This command renews the PACTOR firmware in the Flash ROM of the PTC-IIpro. It should only be used together with the corresponding program on the PC.

### **14.3.10 Version**

Displays the version number of the BIOS.

## **14.4 BIOS SYStest commands**

### **14.4.1 BATtery**

Checks the internal lithium-battery being for SRAM-backup. When the battery is good then it reports `Battery OK..` When the battery is weak it reports `Battery LOW! .`

### **14.4.2 Beep**

Produces a short beep tone.

### **14.4.3 Cfg**

Configurations register readout and display in hexadecimal form.

### **14.4.4 CHKFlash**

Check Flash-ROM for valid PACTOR firmware.

### **14.4.5 CHKRam**

Calculate RAM checksum and display in hexadecimal form.

### **14.4.6 CLr**

Erase RAM checksum variable. This is guaranteed to cause a 'loading' at the next switch on.

### **14.4.7 Help**

Displays all useable commands. It is also possible to obtain further help on a command whilst in BIOS with `Help <CMD>`.

More details to the `RUN` command

**sys: Help** RUN <Return>

#### 14.4.8 Led

Checks the LED's. The PTC-IIpro tests the whole lighting console.

#### 14.4.9 Quit

End the SYStest.

#### 14.4.10 RAMCLR

Clears the complete RAM.

#### 14.4.11 RTCTrim

**Default setting: 3**

Parameter: X            1...7

With **RTCTrim** the inaccuracies of the realtime-clock can be compensated. With the default value of 3 the clock can have a deviation of +- 120 seconds per month at 25°C temperature. Values larger than 3 slow down the RTC while values smaller than 3 speed it up.

#### 14.4.12 RUN

Start the PACTOR firmware.

#### 14.4.13 SERNum

**SERNum** displays the serial number of the PTC-IIpro. This number always has 16 digits. **SERNum** answers as follows:

Serial number: 01000005A6E69C22

#### 14.4.14 Trxtest

Tests the transceiver control port. Only works in conjunction with the appropriate test adapter!

## Chapter 15

# 15 Circuit Description

### 15.1 The Processor section

The **SCS**-PTC-IIpro is designed as a 32 bit processor system, based on the communications processor MC68360 (QUICC<sup>4</sup>) from Motorola. This processor contains an expanded 32 bit core of the well known 68020 CPU, as used in many powerful computers, together with four separate programmable serial communications ports, the so-called SCC's. Two of these SCC's serve as the interfaces to the Packet-Radio modems and are able to do the HDLC protocol inclusive CRC calculation independently from others.

One SCC is used as an RS232 interface to the terminal. A buffer chip MAX207A is superposed, which provides the correct RS232 voltage levels and is used as a buffer. The serial interface is totally implemented and has all handshake wires. The baud rate to the terminal (max. 115 kBaud) is detected automatically and needs not be set.

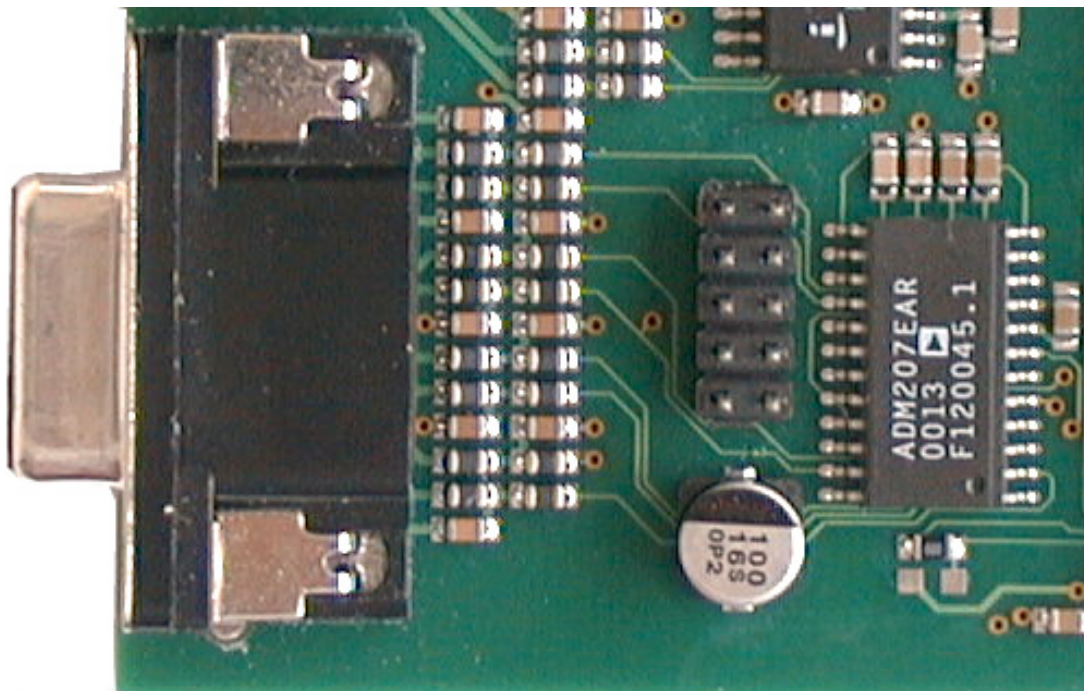

Figure 15.1: The serial interface

The last remaining SCC serves to interface to the HF transceiver, for remote control purposes. All necessary signals to control the YAESU, KENWOOD, ICOM, SGC and R&S transceivers are available on a 13-pole-DIN socket. This interface is capable to provide serial data streams with TTL- as well as V24-levels.

---

<sup>4</sup> Quad Integrated Communication Controller

The four SCCs are controlled by an independent RISC processor within the 68360, because of this the described operations run absolute simultaneously, loading the processors cernal only very little.

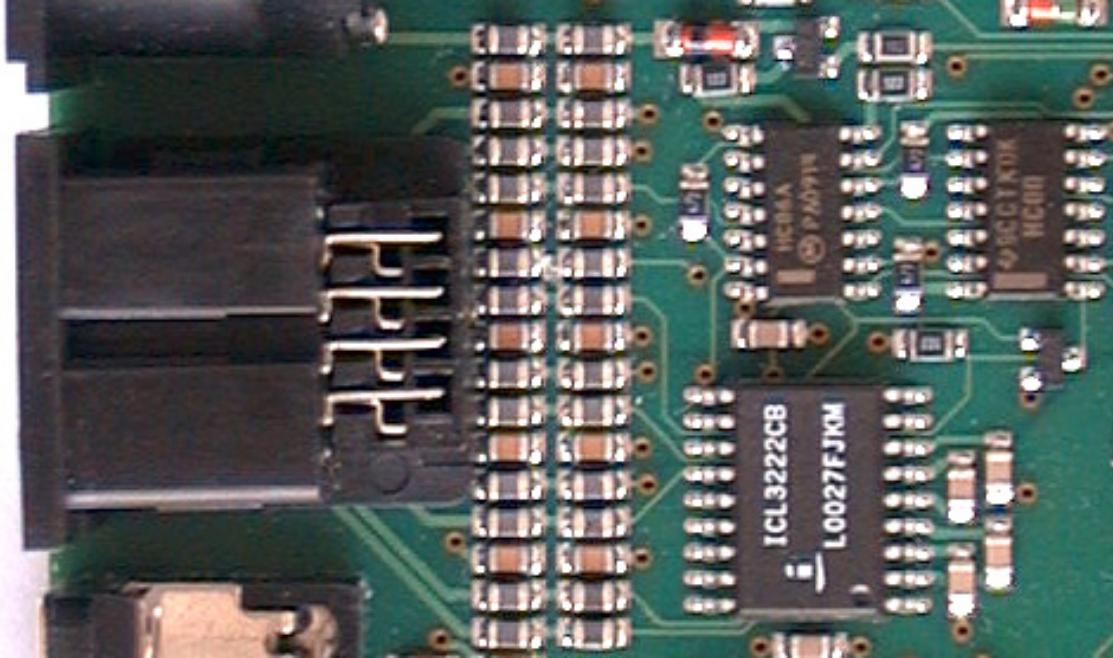

Figure 15.2: Transceiver remote-control in detail

Four RAM chips with eight bits each are required to cover the 32 bit wide data bus. The PTC-IIpro provides 2 MB of static RAM, which plays a large part in running the mailbox and internal administration.

A flash memory with a capacity of 256 kByte contains the software of the PTC-IIpro as a compressed file. This enables the PTC-IIpro to accept updates easily to be downloaded from an external computer using the V24-interface.

After switching on the PTC-IIpro the operation software is expanded from the 8-bit flash, loaded in the 32 bit static RAM (boot) and started. The operation software uses the 32 bit data bus and runs with the maximum possible CPU speed.

Operating parameters for the PTC-IIpro, that should be resistant even to a deep reset, are also stored in the flash memory. Data in this kind of memory remains stored, even when no voltage is applied, but contrary to an EPROM, may be electrically erased and re-written whilst in circuit. A battery backed up real time clock and other features of the previous PTC are, of course, still included.

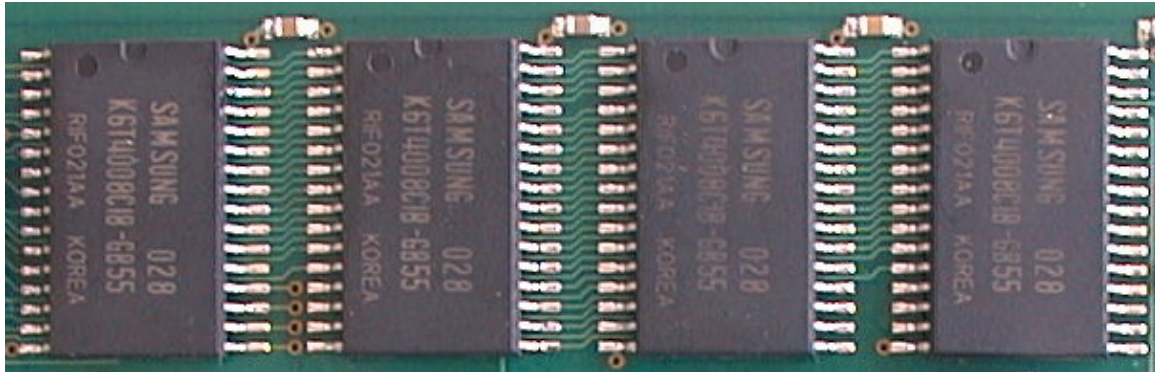

Figure 15.3: Masses of memory

## 15.2 The shortwave modem with signal processor

The XC56303 DSP from Motorola forms the interface to the shortwave transceiver. It runs with a clock frequency of 100 MHz and performs 100 MIPS. As the clock frequency is programmable, it is automatically adjusted to suit the work of the moment. For easy tasks, such as FSK, the processing speed can be reduced, yielding a corresponding saving in energy. A 16 bit CODEC (digital  $\leftrightarrow$  analog converter) is used, with the help of which the audio output signal to the transceiver is generated, be it simple (A)FSK, or the complex phase modulation of PACTOR-II. The output amplitude is also programmable and may be set in the range between 30 mVpp and 3Vpp in 1mV steps by software command. The normally required MIC Gain potentiometer is thus missing.

It is also possible for the PTC-IIpro to control the output power of the transceiver, so that the power to maintain the link may automatically be adjusted to an optimum value. No more power than needed is being used.



Figure 15.4: Mathematical artist, the processor

For the signal input, the DSP uses a Sigma/Delta analog to digital converter with a 16 bit dynamic range, which enables the normally necessary anti-alias filter to be dispensed with. With the exception of the decoupling OP-AMP, at the input and output of the CODEC, no further components in the signal path are required. The DSP contains a



Figure 15.5: All digital, the signal processor with RAM

built-in static RAM, which, in the PTC-IIpro, is further expanded with two additional, very fast, static RAMs with a size of 256k-words (24 Bit). This enables difficult algorithms, for example 4096 point FFT, to be used. The DSP has direct access to the main processor's data bus, it does not tie up an SCC.

The exact receive frequency of PACTOR-II is achieved very quickly and reliably, adjusted by software, using a newly developed tracking method, a frequency deviation between connected stations up to 100 Hz is allowed. The complex modulation scheme, often used, but very difficult to handle because an adjustment to only a few Hertz was necessary, is gone.

### 15.3 The Power supply

The PTC-IIpro contains two power supply input options, which can be used optional. It may be supplied either via a special DC input connector, or directly from the HF transceiver, via the connecting cable and socket. The two options are decoupled via diodes, and feed a switching regulator. This is very efficient, and generates the 5 V supply for the digital section. The supply voltage can vary between 10 to 20 V DC. The current requirement, due to the use of the switching regulator, is dependant upon the supply voltage, the Packet-Radio modems used and the processor speed – usually it is 200mA at 13,8 V. The higher the supply voltage, the lower the current consumption. This reverse proportionality is due to the fact that the power consumed is a product of voltage and current, and must be virtually the same, before and after the regulator. The power supply input of the PTC-IIpro contains special filtering, so that the switching harmonics from the regulator cannot reach the outside world. The operating voltage is internally fused with a self-resetting fuse.

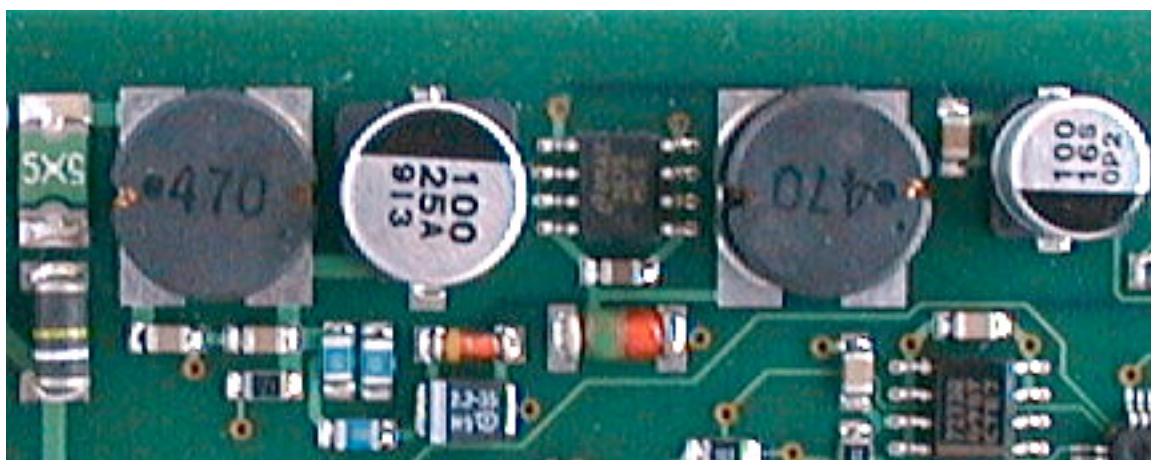

Figure 15.6: The PTC-IIpro switch-mode power unit.

## 15.4 The display and indicator unit

The display and indicator unit is built on a separate circuit board, and sits at right angles to the main board, connected by soldering pads. It carries a tuning indicator of 15 LED's, 9 further LED's to display the various operating parameters of the shortwave channels, 3 LED's for each Packet-Radio port and a ten character 5\*5 dot matrix LED display, used to indicate the operation mode and to ease the indication for further supplements.

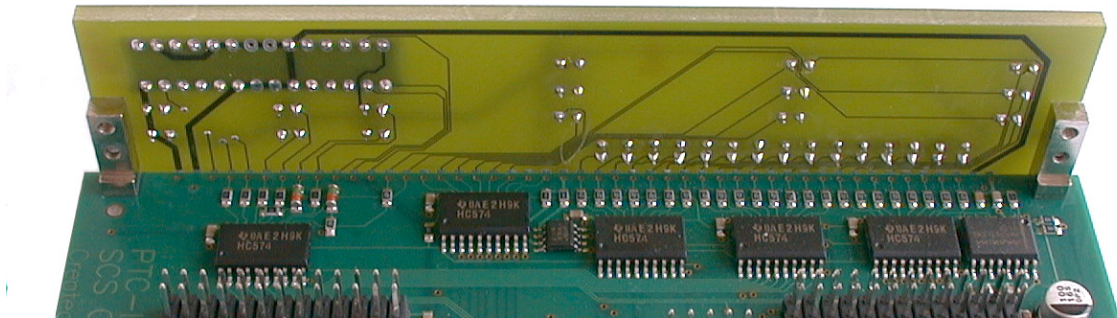

Figure 15.7: A good connection

The display is readable from greater distance and wide viewing angles. The brightness of LED's and display are programmable.

Most of the LED's, including the tuning indicator, are dual color types, to increase the information density, and to ease the reading of the display. The tuning indicator of the PTC-IIpro, for example, is combined with a center indication to display the frequency variation to connected stations in steps to 10 Hz. The front panel is multicolored to ease the assignment of LED functions.

## 15.5 The Packet-Radio ports

The PTC-IIpro contains connectors in the form of double PCB strip headers to mount at a maximum two Packet-Radio modems. The primarily concept of the PTC-IIpro was the use as a controller for the shortwave modes. Because of that the Packet-Radio has to be enlarged by plug-in modules optionally. These modular concept offers a high flexibility and a compact design. After the modems are inserted the operating system recognizes the modems automatically.

## 15.6 The Construction

The PTC-IIpro is made up of two printed boards, a main board of 147\*175 mm, and a front board, which contains the displays as described above. The main board is a six level multi-layer construction, and contains internal ground and supply voltage areas. On the back is the DC input, an ON/OFF switch, an 8 pin DIN socket for the HF transceiver, two five pin DIN sockets for Packet-Radio, an 13 pin DIN socket for the transceiver control,

## 15 Circuit Description

---

as well as a 9 pin SUB-D socket for the terminal connector. On the front is a row of 52 finger pads for solder connection with the front board.

The construction is largely SMD. Every single pin of every socket has its own T-filter, in order to improve the HF rejection in strong RF fields, as well as to prevent unwanted radiation of electromagnetic energy. This method is not only used to meet the restrictions of the government, but it is used in practice as well. The PTCplus, decoupled with the same method has furnished proof to bear up under the electromagnetic pulse of a nuclear explosion (tested by 50kV/m field strength in a NEMP simulation plant of the German armed forces).

The whole is enclosed in a new developed aluminium profile case. Both front and rear of the case are multicolored printed.

## 15 Circuit Description

---

## Chapter 16

### 16 Basics

#### 16.1 Why PACTOR?

PACTOR (*Latin: the mediator*) is a modern radio teletype mode developed in Germany by **DF4KV** and **DL6MAA** to improve on inefficient modes such as AMTOR and PACKET-RADIO in weak short wave conditions.

The AX.25 PACKET protocol certainly has its advantages on VHF/UHF FM channels, but gives a lot of problems on short wave:

- The data rate of 300 baud combined with a large packet length used by many radio amateurs is very susceptible on fading or multipath conditions and QRM.
- The large protocol overhead dramatically reduces the amount of information contained in a packet.

AMTOR had been developed specially for transferring text on an HF channel. Even weak signals under distorted conditions, where a PACKET connect would never be possible, could be copied. But AMTOR also has its disadvantages:

- Using 5 bit code makes it impossible to transfer the whole ASCII character set or binary data.
- Detecting and correcting errors is insufficient for error free transmission of binary data.
- The effective data rate is only 35 baud.

PACTOR offers a much better error correction system, and a considerably higher data transfer rate, than AMTOR. The synchronous transmission format, and the short packet lengths of AMTOR, have been retained. These result in a protocol much more resistant to interference than Packet-Radio under poor propagation conditions.

The PACTOR protocol, together with the **SCS**-PACTOR Controller, allows a much higher throughput than AMTOR, with the efficient error correction and data transparency of Packet-Radio.

One should not, however, be under the impression that PACTOR is just a combination of Packet and AMTOR! Although essential parts of both systems have been included, such as data integrity, by using a CRC from Packet, and the synchronous transmission format and short block lengths (compared to Packet) of AMTOR, a fully new concept has also been included from the very beginning. For the first time in amateur radio, online data compression is used to markedly increase the effective transmission speed. Also the use of memory ARQ in PACTOR is a milestone, although it has been known for a long time in the commercial sector.

Previously it has been very difficult, or impossible, to apply this concept in amateur radio. The use of memory ARQ is the main reason that PACTOR does not lose the link under bad conditions. With memory ARQ, defectively received packets or blocks are not just

simply thrown away. They are stored and added to other defective packets, until enough data is collected to reconstruct the original packet, and thus keep the link during operation. The original **SCS**-PTC uses a real analogue memory ARQ, whereby the received AF tone is not simply turned into 0 or 1 data, but intermediate values are also stored. Therefore a more fine-tuned analysis is possible than with so-called "digital memory ARQ".

## 16.2 Why PACTOR-II ?

PACTOR Level I has established itself, in the last few years, as the new standard for FSK radio teletype on HF links. With PACTOR-I it was possible, for the first time, to utilize the possibilities of an almost ideal combination of simple FSK modulation combined with an ARQ protocol nearly perfect. Even now, PACTOR-I, with analogue memory ARQ, has shown itself to be the most robust, narrow band radio teletype system available using FSK modulation, though another relatively similar FSK ARQ protocol has recently been developed.

In the meantime, the signal processor technology (DSP) has reached a stage where the implementation of high performance modems with a reasonable price to performance ratio is possible, and because of this it becomes interesting for the radio amateurs and? now a requirement - as with the development of the PACTOR-I protocol about 8 years ago - for a radio teletype system which takes maximum advantage of the possibilities offered by modern hardware, and which can be classed as "state of the art".

The main question was, what could be improved in PACTOR-I. A bit of head scratching provided the answer. First of all a significant improvement has to be done to the working range, which requires greater adaptability. In practice this means that even extremely weak or disturbed signals should still allow a connection, even if they are so bad that PACTOR-I can no longer transfer data. On the other hand, observations have shown that PACTOR-I links often work at 200 baud, virtually without repetitions, on the higher bands. In any case, the effective information speed (when required, i.e. when data is really available) should be increased, so that data is transferred as fast as propagation will allow.

For a new protocol the following conditions of compatibility should be observed:

4. All advantages of the *old* protocol should be obtained.
  - Step synchronous ARQ protocol.
  - Simple half-duplex operation with short packets during a direct QSO (*high spontaneity*)
  - Full data transparency (binary, ASCII, Huffman, Markow, etc.).
  - Full support of analogue memory ARQ.
  - Should be able to connect under poor S/N ratio conditions, and with a short phasing time. (no requirement for a valid CRC to connect, therefore short pause times for scanning BBS).

- Independence from sideband selection (no mark/space convention or similar limitations).
  - Free choice for the center frequency of the audio signal in a range between 400 Hz and 2600 Hz.
  - Longpath option (ARQ links over the long path possible).
  - Reliable QRT acknowledgment from both sides (not just a simple time-out).
  - Fast and reliable change of data direction.
  - High performance *read* function without additional software.
  - Capable of running as a *stand-alone* controller i.e. independence from IBM compatible PC's.
5. Full compatibility with the *older* protocol.
- Automatic switching between Level-I and Level-II at contact initialization. (The user should be able to use the usual command syntax **C** CALLSIGN to start a PACTOR contact, without having to worry about the other station's system level).
6. A bandwidth of less than 500 Hz at -50 dB, so that operation within 500 Hz channels is possible.
7. Constant bandwidth, irrespective of the actual effective transmission speed.
8. The acknowledgment signal (CS) should be equally as robust, or even more so, than the actual data signal.

All the above points are fulfilled with PACTOR-II, and not only those. PACTOR-II uses an extended and better on-line data compression system known as Markov coding. A reliable and automatic frequency correction, adaptive cycle length, and many other useful features are also incorporated.

### 16.3 Basics of the PACTOR-II protocol

#### 16.3.1 General

The PACTOR-II protocol (PT-II) is essentially based on the Level-I standard, consisting of a synchronous half-duplex ARQ protocol. New, however, is the ability to choose four different speed steps, so that a greatly improved adaptability is obtained. The modulation system used for PT-II is based on DPSK (differential phase shift keying - see below), which leads to a very narrow spectrum, practically independent of the data rate. The robustness of the DPSK modulation qualifies itself noticeably higher at lower information speeds in comparison to FSK. In order to effect a further step towards robustness, PT-II uses high performance convolutional coding, that is evaluated with a real Viterbi decoder in the data receiver (see below). The high correction capability of the decoder allows not only links with extremely weak or noisy signals, but also, with more normal signals,

enables short error bursts, or fadeouts, to be entirely ignored, and a repetition of that packet is not required. This is especially important with PT-II, as the new protocol allows switching to a triple cycle length if there is enough data in the transmit buffer. The relatively long resultant data packet would be very prone to impulse errors from clicks or atmospherics (QRN), if not for the highly effective error correction designed.

### 16.3.2 The modulation system

As with the previous FSK standard, PACTOR-II also uses two tones (or carriers). These are, however, not just sent alternately to transmit the data, they are both sent together as continuous tones. The data is contained in the phase of each tone, or, to be more exact, in the phase difference between two consecutive information states or steps. The keyword *step* should be more exactly explained, so that an essential part of the PT-II modulation system, the pulse shaping, can be understood. The FSK system uses rectangular keying (or steps) throughout. With 100 Baud operation for example, a high (mark) tone of exactly 10 ms is transmitted if a logical 1 is sent, or a 10 ms low (space) tone if logic 0. Every step at 100 baud takes exactly 10 ms and starts and stops very abruptly, i.e. a square wave. This abrupt keying produces a relatively wide frequency spectrum. That the two tone FSK keying bandwidth remains tolerable is only due to the fact that no phase shift takes place during the tone keying (providing a correctly adjusted modulator may achieve this). Phase modulation on the other hand, has, by its very nature, a phase jump between each step. A square wave modulated PSK signal has therefore a very wide frequency spectrum, and should never be used on the (in any case much too narrow) HF amateur bands. The number of steps (or changes) per second is called the *symbol rate*, or (a little less correctly) baud rate.

Harry Nyquist, one of the most well known of the earlier communications experimenters, developed, as early as the twenties, a mathematical model that described exactly the relationship between bandwidth and the maximum step speed, which finally led to his sampling theory. Stemming from his work, a special step or impulse waveform was found that contained the ideal characteristics for data transmission over an electrical circuit.

A special version of this waveform, with even better characteristics, led to the so-called "raised-cosine" waveform. (For insiders: the form of the spectrum is equal to the squared cosine function, or the cosine function plus one). The special properties of the "raised cosine pulse" are as follows:

1. The spectral bandwidth of a carrier modulated with the RC pulse is ideally only double the symbol rate (in hertz) - without any spillover or nearby spurious responses. In practice it is possible to reach a spurious attenuation of around -50 dB.
2. At the sampling points (e.g. every 10 ms for a step speed of 100/sec) the RC pulse presents a "zero crossing" to all except the *correct* sample point. This means that the impulse can be completely overlapped at the sampling distance, although the pulse itself may exhibit a multiple of the computed step length. This leads to a very high information density. To clarify this point, Fig. 3.1 shows the sampling points of a 100 baud RC pulse.

- Even the complete signal, comprising numerous overlapping RC pulses, always shows a "zero crossing" between the sampling points. This "zero crossing" enables any timing errors to be measured, and thus the PT-II system to be kept in synchronization.

It is obvious to use two RC modulated signals, with a spacing of 200 Hz (*Shift*) in parallel. The complete signal then shows a spectrum 450 Hz wide at minus 50 dB. PACTOR-II utilizes exactly this modulation scheme, using two tones, and a modulation rate of 100/sec. This is a relatively low value, and is a good compromise between robustness in noise, and resistance to multipath effects. As the two tones work in parallel, the PT-II system reaches a total modulation rate of 200/sec. The reason why differential PSK is used on HF links is that signals are much too unstable and noisy (or with too large a frequency error) to be used effectively by "normal" coherent PSK detectors.

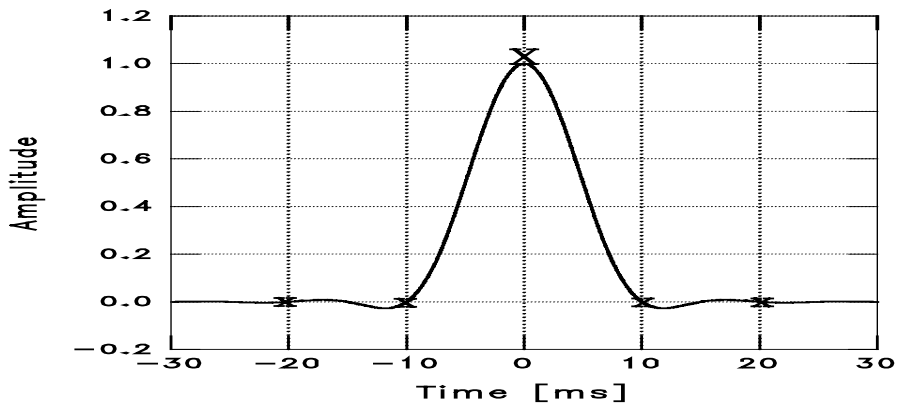

Figure 16.1: Raised-Cosine-Pulse, Sampling points marked X.

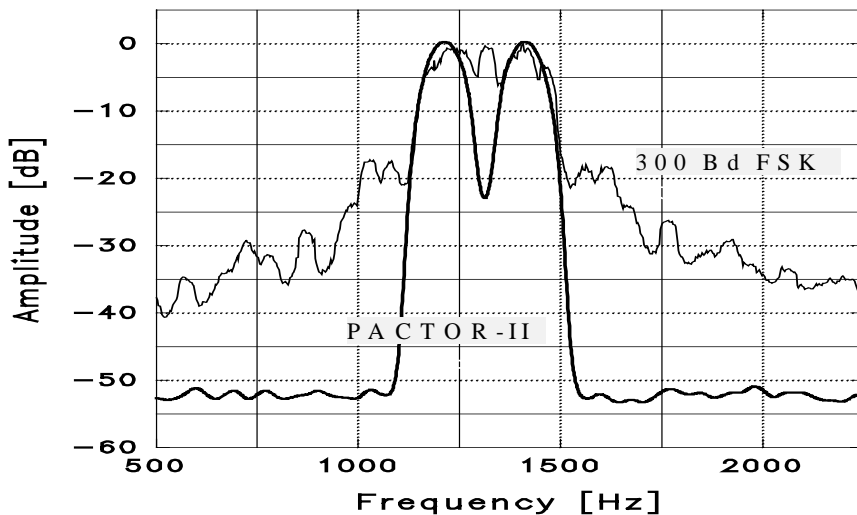

Figure 16.2: PACTOR-II spectrum 300 Bd FSK (200 Hz Shift)

For arguments sake, if there are only two possible phase changes between the steps it's called differential binary phase shift keying (DBPSK). Every step contains exactly one bit

of information. If four different phase changes are allowed, then the modulation is called "differential quadrature phase shift keying" (DQPSK). Every step of course then carries two bits of information. With eight or sixteen allowable phase changes, the modulation is called 8-DPSK or 16-DPSK, each step containing three or four bits of information respectively. The required signal to noise ratio, however, climbs rapidly, as the number of allowable phase changes increases. Table 1 shows the total bit rates for the PT-II modulation scheme (without data compression).

Modulation Scheme	Total bit rates (Bit/s)
DBPSK	200
DQPSK	400
8-DPSK	600
16-DPSK	800

Table 16.1: Total Bit Rate

The complex PT-II modulation scheme is totally different to the simple FSK. Therefore it is IMPOSSIBLE to use the FSK modulators found in some transceivers to generate the signal. The PT-II signal must always go via the indirect route, by using SSB to generate the HF signal.

This has actually no disadvantages, providing the transceiver is not overdriven (see below).

A further very essential difference between the *older* FSK modulation and the multi-tone DPSK modulation has to be mentioned. With FSK modulation the output power of the transmitter remains constant during the entire transmission because alternating square wave pulses of each tone are transmitted, and mathematically the total amplitude adds up to a constant function. This could be called a *constant envelope*.

As the amplitude remains the same, non-linear amplifiers, or even class C power amplifiers, can be used without problems. Speaking about a complex modulation method, e.g. used in PT-II, a more or less *variable envelope* must be considered. This means, in practice, the following two points have to be observed:

In all modulation methods using a changing amplitude HF signal (e.g. PACTOR-II, SSB-speech modulation, AM etc.), it is NEVER allowed to overdrive the transmitter because intermodulation products will be generated broaden the signal.

How to adjust the maximum transmitter power will be described in the `PSKAmp1` command (refer to chapter 6.74 on page 97). It always has to be taken in consideration that, with a variable amplitude modulation system, the effective average power is lower than the peak power. With PACTOR-II this ratio between peak power and average power is almost exactly 2. (For insiders: the square root of this ratio is called the crest factor, and with PT-II has a value of around 1.45). This value is considerably lower than with other multi-tone systems, and has shown itself to be very well matched to the usual SSB transmitter. If one sets a peak power of 100 watts, then the PT-II signal produces an average output of about 50 watts. The full PEP output of an SSB power amplifier can be thus used without great fear of overload, conditions being similar to those existing during normal SSB speech transmission.

### 16.3.3 Error control coding

The basic idea behind error correcting codes is that extra checking information is transmitted along with the required data, so that the *redundancy* of the signal is increased. The greater the efficiency of the redundancy employed the better the code, and the greater its error correcting abilities. The ratio of useful information to total information (=useful information plus redundancy) is called the *code rate*. A very simple code, the (7,4) Hamming code for example has a *code rate* of 4/7, as for every four useful bits of information, three redundancy bits are added. It can correct exactly one bit error per block of seven bits. If however two or more bits have their polarity changed in transmission, then this simple code fails.

The coding theory distinguishes between two main classes of codes: The block codes and the convolutional codes. In block codes (e.g. Hamming codes, the Golay code or Reed Solomon codes), the data stream is chopped into relatively small pieces called blocks. The coding rules or algorithm is then carried out on these blocks. Block codes were the first to be developed due to their simplicity. Unfortunately, in practice they have all proved to be rather weak, as only a very few bits per block can be corrected. The (24,12) Golay code for example can only correct a maximum of three bits in a block of 24, even though there is a redundancy of twelve bits contained in each block. The coding rate is therefore classed as 1/2. (for insiders: The problem with block codes is mainly that they do not adhere to one of Shannon's theorems. According to Shannon, good codes should be as long as possible, and as unsystematic as possible).

At the beginning of the sixties, the convolutional codes began to slowly gain importance. In this form of coding, a message (or a data packet) is coded as a complete entity. The actual encoder consists of a tapped shift register, and carries out an algorithm which strongly resembles the mathematical convolution integral - hence the name. The length of the shift register is called the *constraint length*, and sets a limit to the correction capacity that can be achieved. To decode convolutional codes, a number of different methods can be employed. The optimum decoder, that really can achieve the maximum possible gain from the code, is called a Viterbi decoder. Unfortunately, there is an exponential relationship between constraint length and the computing time required by a Viterbi decoder. This is why the use of the Viterbi decoder for real time tasks has been limited to a maximum constraint length of six for many years. The present day generation of DSP's in the meantime, allow use to constraint length nine or in special cases, even more. As opposed to block codes, convolutional codes with a Viterbi decoder easily allow the fine analogue resolution of the received signal to be included in the decoding process, and hence even more gain to be obtained. This method is called *soft decision*, and, depending on the form of interference present, can give several dB additional gain compared to *hard decision*.

Another point, which occurs often in connection with coding, is so-called interleaving. This is nothing more than a shuffling of the data. All codes, irrespective of whether block codes or convolutional codes, when developed for maximum gain in noise, react more or less over sensitively to short error bursts. On HF channels, the error burst (QRN, clicks, short *fadeouts* etc). is about the most prevalent form of error found. In any optimized error correction method for shortwave use, it is obligatory to use interleaving. Usually the transmitted data is dismembered into short blocks (e.g. 16 bit long strings) that are stacked one over another in a memory. The data is then transmitted, not in the original

sequence, but in vertical rows. At the receiver, exactly the reverse operation occurs. If during transmission, an error burst takes place, this is cut into relatively widely spaced single bit errors by the interleaving / de-interleaving process. These bit errors resemble noise during the de coding, which the decoder is designed to handle easily.

PACTOR-II is based on a convolutional code, with a constraint length of 9 and a Viterbi decoder with soft decision. The coding rate varies between 1/2 and 7/8. The four possible speeds are shown in Table 16.2

Modulation	Coderate	
DBPSK	1/2	100
DQPSK	1/2	200
8-DPSK	2/3	400
16-DPSK	7/8	700

Table 16.2: The four speed settings and coding.

### 16.3.4 Online data compression

As with the Level-I protocol, PACTOR-II uses Huffman coding for text compression on a packet by packet basis. As an alternative, PACTOR-II can also use pseudo Markov coding (PMC) as a compression method. PMC has been developed by **SCS**, and increases the throughput of plain text by a factor of 1.3 compared to Huffman coding. The PTC-IIpro examines each packet individually to see if it would be faster to send it using Huffman, PMC, or normal ASCII transmission. There are thus no disadvantages incurred by using PMC. As a further selection criterion, the PT-II protocol supports separate German and English coding tables for PMC, as well as a capitals mode for Huffman coding and PMC. There is a total of 6 different compression variations available for use. The PTC-IIpro checks each packet automatically, and then very reliably chooses the best compression method for transmitting the data. Additionally, PT-II uses "run length coding", so that sequences of repeated characters, e.g. underlining, or columns in graphics, may be transmitted very efficiently. With "run length coding", the system does not transmit each character individually, instead an sample character is sent, followed by the required number of same.

A few words on how PMC functions would not be out of place here. Normal Huffman compression makes use of the statistical frequency distribution of characters in plain language text. The characters most used (e.g. 'e' and 'n' ) are coded with only two or three bits. Rare characters such as 'Y' can conversely be up to 15 bits long. On an average, one obtains a symbol length of around 4.7 bits, which is a considerable compression factor compared to 7 bit ASCII of constant length. The Markov coding, to put it very sloppily, is like a *doubled* Huffman compression. Here it is not just the simple frequency distribution of characters which plays a role. Instead, the interest is in the frequency distribution of the *leading*' or initial letter of any two byte sequence. Let us take our example of an 'e'. It is very probable that an 'n', an 'r' or a 't' may follow. On the other hand, it is extremely unlikely that an 'X' would be the next character. The resultant frequency distribution is more accurate than the simple frequency distribution of the characters in a text, and therefore allows a better compression. Every *leading* character should allow, in principle, its own Huffman code for the following character to be built

up. Every *leading* character therefore lays down its own Huffman table for the following characters.

Unfortunately, although very convincing in theory, this system has two very obvious weak points. Firstly, the coding table would be impracticably large, as there would have to be a Huffman table for every character. Secondly, the least common characters in particular, show a very unstable (context dependent) resultant probability, and it must be reckoned that particularly these characters would lead to a decrease in the effective transmission speed with (non-adaptive) Markov compression.

The **SCS** team, in developing PT-II, came up with a simple and clever answer to these problems. The Markov compression would be limited to the 16 most common *leading* characters. All other characters result in normal Huffman compression. We have thus a hybrid of Markov and Huffman coding, that we have named "pseudo Markov coding. The coding table remains reasonably small, and the uncommon characters can no longer cause trouble due to their unstable probability results. In practice it has been shown that PMC almost always produces a greater benefit compared to normal Huffman compression.

## 16.4 PACTOR-II in practice

### 16.4.1 General points

Those experienced users of PACTOR-I should have no trouble changing to PACTOR-II, particularly if they know the usual commands of the **SCS** controller for PACTOR operation. Before the first try-out on the air a check should be made, using the **MYcall** command (refer to chapter 6.63, page 90), to see that one's own callsign has been correctly loaded into the PTC-IIpro from the terminal program. If this should not be the case, then put in the callsign manually using the **MYcall** command. Other than this, it is essential that the AF output level, together with the maximum output power in FSK and DPSK are correctly set. For this, see the information contained in the description of the two commands **FSKAmp1** (refer to chapter 6.42, page 81) and **PSKAmp1** (refer to chapter 0, page 97). Once that has been done, then one is ready to start. The transceiver can be tuned to say 3583.7 kHz or 14079.0 kHz, and DL2FAK called (providing the frequency is clear). If there is PT traffic on the chosen frequency, irrespective whether PT-I or PT-II, the PTC-IIpro will automatically copy it, providing the `Listen` mode is turned on (refer to chapter 0, page 85). As with previous PTCs', a connect is started with

**cmd: c** CALLSIGN <Return>

At the very start of a link, the two controllers automatically agree to use the highest common level. This functions with all known PACTOR-I equipment, as these all contain a correct implementation of the Level-I protocol for the initial link. At present, we know of no PT-I implementation which does not work correctly with the automatic level setting during the initial link-up. The user knows virtually nothing of the auto level setting procedure and does not have to concern himself with it. In the case where a Level-II link is set up, the LED display jumps from `PT1:` to `PT2:` and the appearance of the tuning indicator changes drastically in comparison to the usual FSK tuning help.

## 16.4.2 The tuning indicator and tuning behavior

The tuning indicator consists of 15 dual color LED's, which, during Level-II operation, not only show the quality of the received signal, but also its frequency offset. Unlike with FSK operation, these two operations are practically independent of each other. With an error free received DPSK signal, only the two outer LED's should flicker. If the signal contains noise or other interference, then some of the middle LED's will flicker, more or less brightly, depending on interference.

The frequency offset is shown separately with one of the 13 inner tuning indicator LED's. If the tuning is exactly correct, then the centered LED is permanently lit. An offset of between ten and sixty Hz causes a shifting of this LED to the left or right by approximately one position per 10 Hz. A shift to the right means the frequency of the partner station is too high. A shift to the left means it is too low. If the difference is greater than  $\pm 60$  Hz, then the next to the last tuning LED blinks.

The DPSK demodulator can only operate correctly when it knows the receive frequency accurately to within a few hertz. Decisions of this accuracy require time. Manually tuning the VFO or using the RIT control on the transceiver **must** therefore cause a number of defective packets to be received, leading to repetition requests. The highly robust and reliable automatic frequency compensation, built into the PTC-IIpro, needs a few seconds to be sure that a sudden frequency change has in fact occurred.

Manual intervention to the tuning does not normally need to be undertaken, providing the automatic frequency parameter (**AQrg**) (refer to chapter 6.5, page 63) is set to '1'. The PTC then adjusts itself automatically to the optimum receive frequency. The QRG display LED can be seen to slowly but surely slide into the center position within a few minutes. (If this should not be the case, then check the AQrg command is set to '1', see AQrg command).

The tuning indicator functions also when using the 'Listen mode', copying PT-II signals within  $\pm 50$  Hz of the correct frequency, exactly as per the connected condition. Here however, the operator should undertake the frequency correction manually, as the PTC-IIpro does not operate with auto QRG in the Listen mode.

## 16.4.3 Speed and robustness

When compared to good old PACTOR-I, PACTOR-II achieves an effective text throughput of around 3 times that of PT-I under average to poor conditions. With very weak signals, or signals with heavy interference, PT-II still works when PACTOR-I will not allow any more data to be passed. Naturally however, the speed of transfer, even with PT-II, drops accordingly. One must get used to the fact, that, with practically inaudible signals, one must wait 20 or 30 seconds for a new line to appear on the computer screen. It has NOT proved to be a disadvantage to continue working with longer packets when signals are weak or under heavy interference. The transmit buffer naturally rapidly fills up under these conditions, causing the PTC-IIpro to switch automatically to longer packets. Only the waiting time until a new line of text appears on the screen increases with the longer packet length, under extremely unfavorable conditions. The effective throughput, however, remains considerably higher than when using shorter DBPSK packets. If the

link threatens to break, then the MAXError parameter (time-out) can be increased to 255, and the Memory ARQ parameter (MAXSum) may be increased to 60 during the contact. **NEVER tune the VFO by hand with very weak or inaudible signals!** With very weak or noisy signals, the PTC-IIpro adjusts its tuning very slowly to minimize tuning error. With good, to very good, propagation conditions, PT-II has shown itself to be 4 to 6 times faster than PACTOR-I. A maximum speed of 140 characters per second can be achieved. This is approximately 30 times the effective AMTOR speed.

Switching between speeds occurs automatically. The operator can influence this a little by using the MAXUp and MAXDown parameter, as with Level-I PACTOR. The PTC-IIpro not only uses the packet statistics as a switching criterion, but also measures the average phase offset from the correct value for every packet, and thereby obtains a very reliable measure of the optimum speed required.

**Important:** The PTC-IIpro only switches to a higher speed if there is more data available to be transmitted, than the actual speed could transmit.

### 16.4.4 CQ calls and broadcasts

As with PACTOR-I, a CQ call or broadcast is normally carried out with 100 Bd FSK UNPROTO mode (see the **Unproto** command (refer to chapter 6.102, page 113)). Such transmissions can be read by all PACTOR users. If, however, only those users with Level-II systems should be addressed, then a DPSK-Unproto transmission can be chosen (see the **Unproto** command (refer to chapter 6.102, page 113)). We recommend the Unproto-3 mode for a DPSK CQ call. This is DBPSK with short packets, and has proved to be the most robust broadcast mode under normal conditions.



## Chapter 17

### 17 Accessories

#### For the PTC-IIpro the following accessories are available:

For the **SCS** PTC series the following accessories are available:

- **Professional-Firmware**  
Firmware with PACTOR-III, PACTOR-IP-Bridge, PACTOR-Free-Signal, Robust-Connect and much more.
- **Packet-Radio 9k6 cable**  
Direct connection from VHF/UHF-transceivers with DATA-connector (6 pin Mini-DIN) to the PTC (5 pin DIN).  
Order-No.: 8050
- **ICOM 8 pin cable**  
ICOM audio cable, PTC 8 pin DIN to ICOM 8 pin DIN (e.g. for M710, IC-735, IC765, IC-M802 and more).  
Order-No.: 8090
- **ICOM 13 pin cable**  
ICOM audio cable, PTC 8 pin DIN to ICOM 13 pin DIN (e.g. for M706, IC-718)  
Order-No.: 8110
- **YAESU Audio cable**  
PTC 5 pin DIN to YAESU FT-817 6 pin Mini-DIN (e.g. for FT-100, FT-817, FT-897). Also usable for 1k2 Packet-Radio.  
Order-No.: 8120
- **KENWOOD Audio cable**  
PTC 8 pin DIN to KENWOOD ACC2 13 pin DIN.  
Order-No.: 8160
- **2 m Audio extention cable**  
8 pin DIN socket to 8 pin DIN connector.  
Order-No.: 8140
- **3 m Audio extention cable**  
8 pin DIN socket to 8 pin DIN connector.  
Order-No.: 8150
- **RS232 Y-cable**  
To easily connect a GPS-receiver to the PTC.  
Order-No.: 8060
- **Packet-Radio DSP Module-II**  
For R300, R600, 300 and 1200 Baud AFSK as well as 9K6 and 19K2 FSK (G3RUH

compatible), also have a look at page 23.

Order-No.: 2320

- **TRX-Control V24 cable**  
TRX-control (13 pin DIN) to 9 pin SUB-D connector and 3.5 mm speaker connector (e.g. for YAESU FT-1000 and KENWOOD TS-570, TS-870, TS-2000 and more).  
Order-No.: 8080
- **TRX-Control V24 cable YAESU**  
TRX-control (13 pin DIN) to 9 pin SUB-D connector and 3.5 mm speaker connector (e.g. for YAESU FT-847).  
Order-No.: 8085
- **TRX-Control cable YAESU**  
TRX-control (13 pin DIN) to YAESU FT-817 (8 pin Mini-DIN) (e.g. for YAESU FT-817, FT-100, FT-897...).  
Order-No.: 8130
- **TRX-Control cable ICOM CIV**  
TRX-control (13 pin DIN) to ICOM CIV port (3.5 mm pin connector) and 3.5 mm speaker connector.  
Order-No.: 8170
- **RS232 connection cable**  
9 pin SUB-D connector (male) to 9 pin SUB-D connector (female). Length 2 m.  
Order-No.: 8040

#### **USB to RS232 converter**

For computers that only have an USB connector but no COM-port.

Shielded cables with molded connectors on one side, tinned open ends on the other side (pigtail), 1,5 meter.

- **Cable with 5 pin DIN connector**  
Order-No.: 8010
- **Cable with 8 pin DIN connector**  
Order-No.: 8020
- **Cable with 13 pin DIN connector**  
Order-No.: 8070

**For price information please refer to our Internet homepage at**

**<http://www.scs-ptc.com>**

**or contact SCS**

---

## Chapter 18

### 18 History

Two German hams DF4KV and DL6MAA initiated the PACTOR project. As early as 1986, experiments with modified AMTOR protocols began. In tedious tests, the noise conditions on the HF-Bands were investigated, and the best transmission parameters were determined. Additionally, a lot of mathematical calculations were performed, the PACTOR protocol deduced from these results.

The first PTC's were wire-wrapped on bread-boards. DL6MAA built his PTC based on a SMD Z80 single-chip processor, while DF4KV wire-wrapped his PTC in conventional Z80 technology.

The third station that got on the air in PACTOR was DL2FAK. His PTC was based on DL6MAA's SMD Z80 version. DL2FAK and DL6MAA ran a lot of tests that resulted in considerable improvements to PACTOR. In the fall of 1989 he developed a PT-link system that facilitated access to Packet-Radio nets from PACTOR.

Since the SMD based PTC of DL6MAA was too difficult for home construction (SMD), and DF4KV's version contained too many parts, it was decided to develop a completely new hardware design.

DL3FCJ developed the digital section of this hardware, DL6MAA developing the modem, and carried out software adjustments. The software was rounded out with inclusion of an RTTY and AMTOR routine from DK4FV. DL1ZAM revised the circuit diagram and produced the printed-circuit-board layout, and so the well known **SCS**-PTC came about, and quickly covered the globe.

In 1993 the production of the Z80-STI peripheral chip, used in the Z80 PTC, ended. This was then the opportunity to develop the PTCplus. Based on an MC68000 processor, the PTCplus is the springboard to a totally new dimension in modern HF communications.

Together with the PTCplus, the development of the PTC-II was also undertaken. The PTC-II project required a thorough knowledge of signal processing technology and it's associated programming. Much research work was necessary to develop the present PACTOR-II modulation process. Despite all this, it was possible to astonish visitors to the 1994 HAM-Radio convention with the first prototype PTC-II.

In summer of 1999 the "small brother" of the PTC-II, the PTC-IIe was ready for sale. Being less expensive at excellent performance and the increasing need of email via HF made the PTC-IIe to be THE standard modem for HF-email within a short time.

Summer 2001 is the time of the PTC-IIpro. Being the successor of the PTC-II, the first PACTOR-II modem, the PTC-IIpro now establishes the new top of **SCS**'s goal to provide the best modem-technology for data transmission via HF at all.

At the first of May 2002 **SCS** introduced the new developed high speed data mode PACTOR-III. PACTOR-III is a third generation HF protocol building on latest developments in 2-dimensional orthogonal pulse shaping, advanced error control coding, and efficient source coding. Due to the advanced signal processing methods applied, PACTOR-III provides outstanding performance under poor and moderate signal

conditions. As PACTOR-III also achieves very high throughput rates under good signal conditions, it is well-suited to HF channels with good SNR and low signal distortion as well. During the development of PACTOR-III, high importance was attached to compatibility with ordinary SSB transceivers (using standard 2.2-2.4 kHz wide IF-filters). Therefore, PACTOR-III can achieve its maximum speed with using unmodified, common SSB transceivers. The occupied bandwidth is around 2200 Hz.

Thus PACTOR-III is the ideal means of fast and reliable data communication over (the sometimes difficult medium) HF-radio. The new protocol is fully backwards compatible to existing PACTOR-I/II networks.

In summer 2003 the PTC-IIex succeeded the PTC-IIe. Although both models nearly not differ from their outer appearance, in the inside the PTC-IIex has been deeply reworked. The PTC-IIex comes with a more powerful DSP section, a TXCO stabilized oscillator, a better power supply and with 2 MB of static RAM.

As an answer to the increasing demand for a modem with USB connection, **SCS** introduced the PTC-IIusb in the mid of 2005.

The ease the use of the PACTOR-IP-Bridge, the same time **SCS** introduced the PTC-IInet. This unit is a neat combination of a HF radio modem with a miniature Linux computer with Ethernet connection, all fitting inside the modem enclosure itself.

## Appendix A

### 19 Technical Data

Audio input impedance:	47 k $\Omega$
Audio input level:	10 mVp-p... 2Vp-p
Audio output impedance:	1 k $\Omega$
Audio output level:	Max. 3 Vp-p (open circuit), adjustable in 1 mV steps.
Audio processing:	Digital signal processor XC56303 clocked at 100 MHz 768 kByte additional DSP-RAM for data and program.
FSK output:	TTL-levels High - mark, Low - space.
Serial interface:	9-PIN Sub-D socket (AT type) 2400... 115200 Baud
Central processor:	Motorola MC68360 QUICC 32 bit CMOS CPU clocked at 25 MHz
ROM:	Max. 256 kByte, CMOS, Flash FLASH-ROM for easy updates
RAM:	static: 2 MByte, CMOS, Battery Backup
Real time clock:	With battery back up.
System monitoring:	With an internal processor watchdog.
Battery:	3 V high capacity Lithium cell.
Front panel:	Labelled. 10 character LED dot-matrix alphanumeric display. A total of 30 LED's split into various functional groups.
Rear panel:	Labelled Input for power supply. On / Off switch. Two sockets for the Packet-Radio ports. Sockets for connection to the transceiver. Socket for transceiver remote control connections. Socket for the serial interface.
Power Supplies:	+10 to +20 V DC, 500 mA max. Reverse polarity protected Fuse selfresetting The current consumed depends on the operating condition and the built in Packet-Radio modems.
Dimensions:	Width 172 x Height 43 x Depth 205 mm
Weight:	730 g
Operating temperature:	-10 to +50 °C



B.1 1k2/2k4 AFSK-Modul

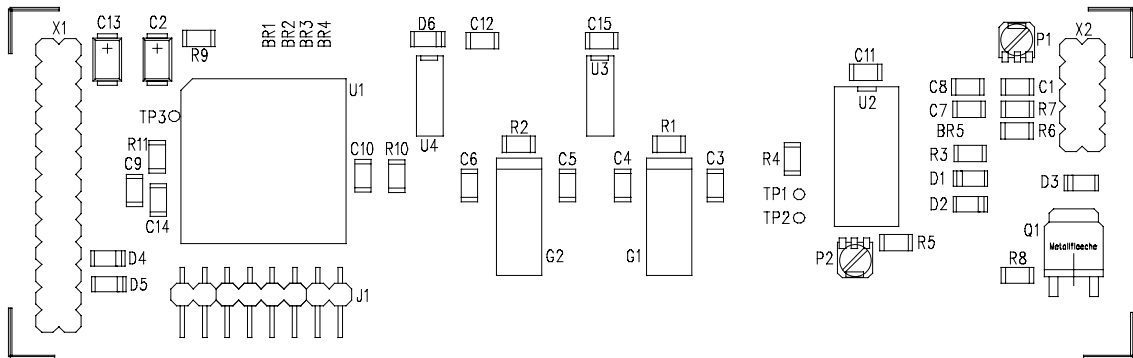

Figure B.1: 1k2/2k4 AFSK module

B.2 9k6 FSK-Modul

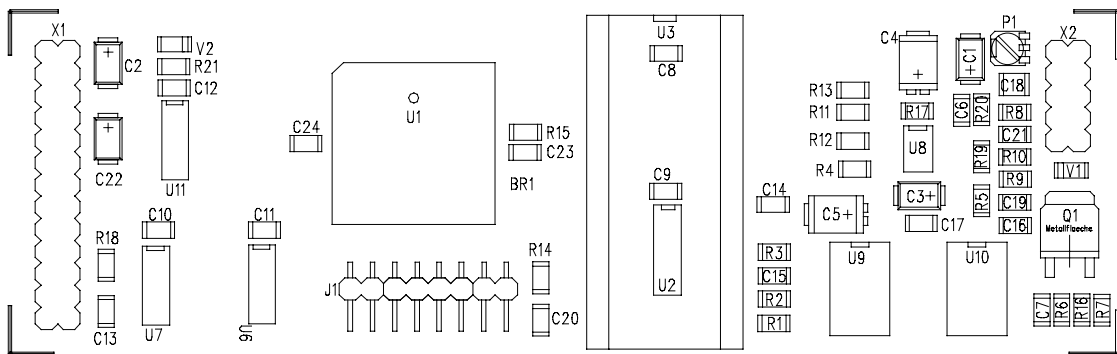

Figure B.2: High Speed FSK module



## B. Layout

### B.6 Motherboard

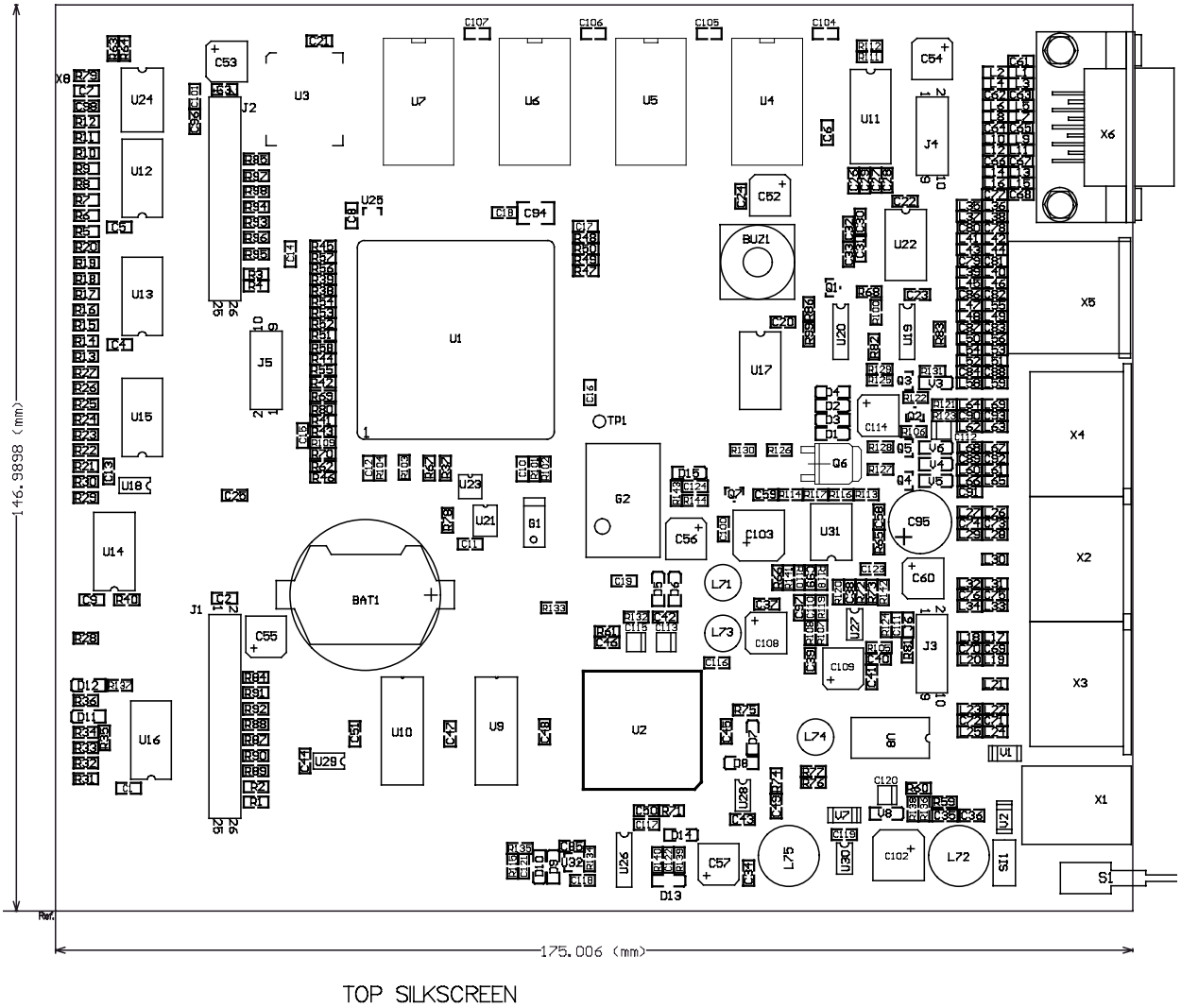

Figure B.6: Motherboard

## B. Layout

---

## Appendix C

### 21 Circuits

The following pages show the most important details of the PTC-IIpro circuit and the circuits of the Packet-Radio modules.

- The Power-Supply
- RS232 Interface
- HF-Transceiver Audio Interface
- HF-Transceiver Control Board
- Packet-Radio AFSK module (1200/2400 Baud module)
- Packet-Radio FSK module (9600 Baud module)
- Packet-Radio DSP module (300... 19200 Baud, multi mode)
- The Y-Cable

#### C.1 The Power-Supply

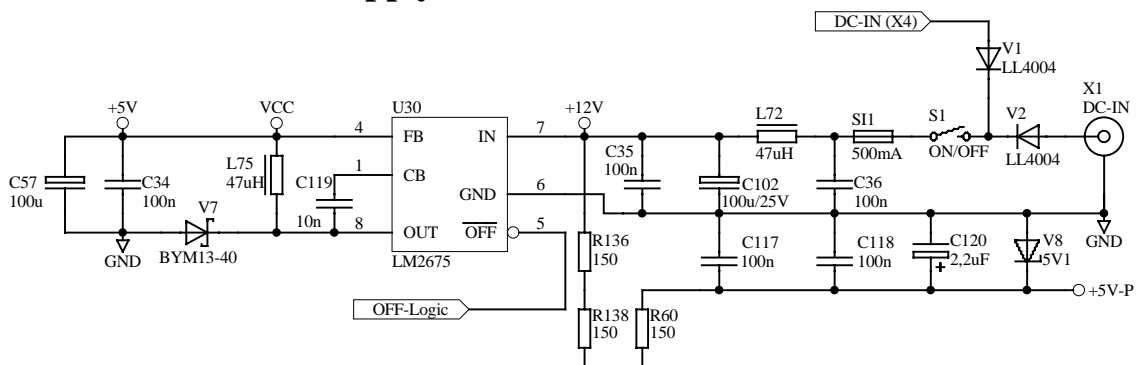

Figure C.1: The Power-Supply



## C. Circuits

### C.3 HF-Transceiver Audio

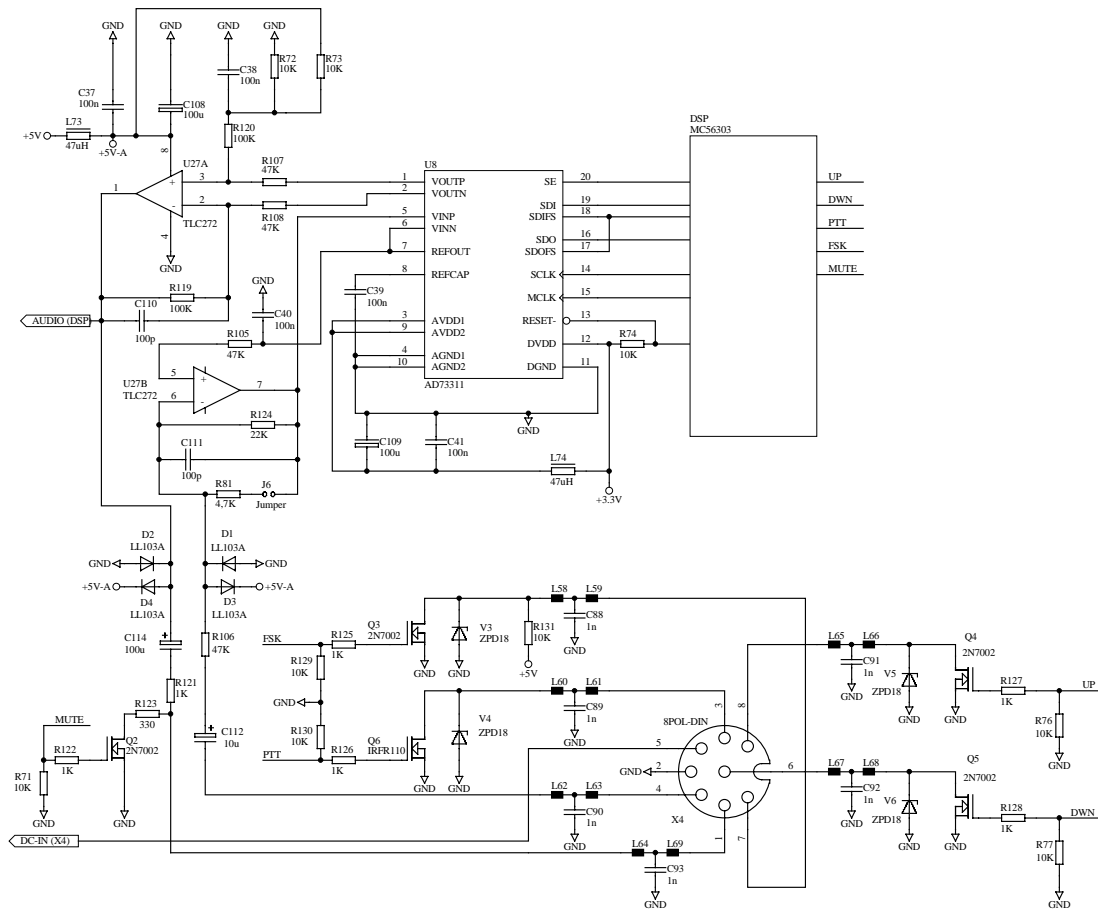

Figure C.3: HF transceiver audio

### C.4 HF-Transceiver Control

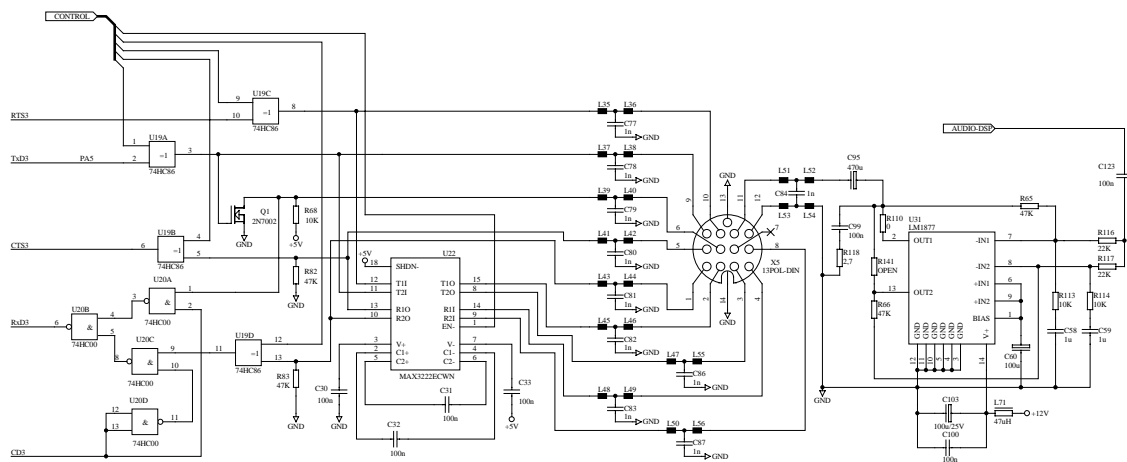

Figure C.4: HF transceiver control

### C.5 Packet-Radio AFSK-Module

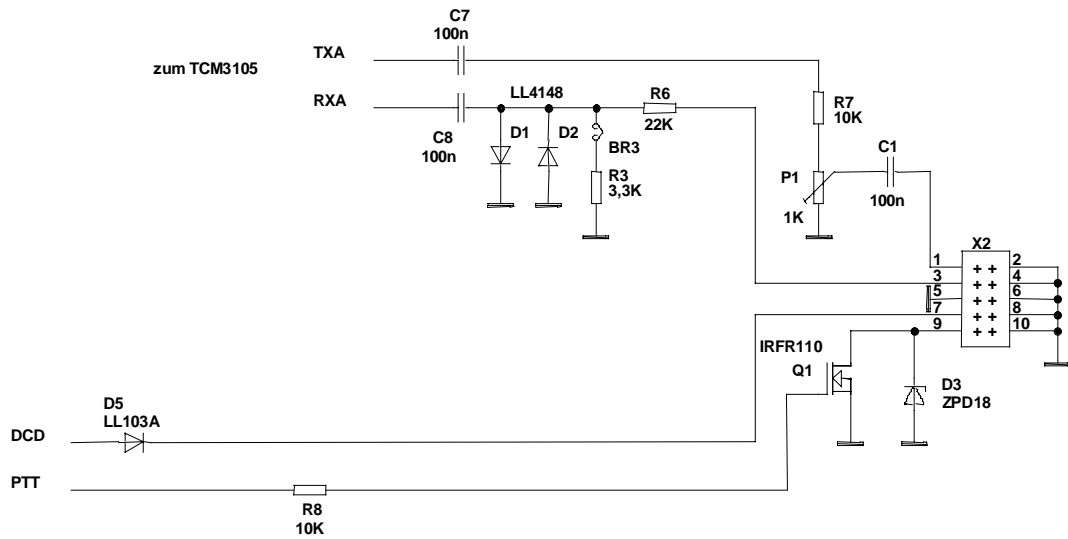

Figure C.5: Packet-Radio AFSK- module

### C.6 Packet-Radio FSK-Module

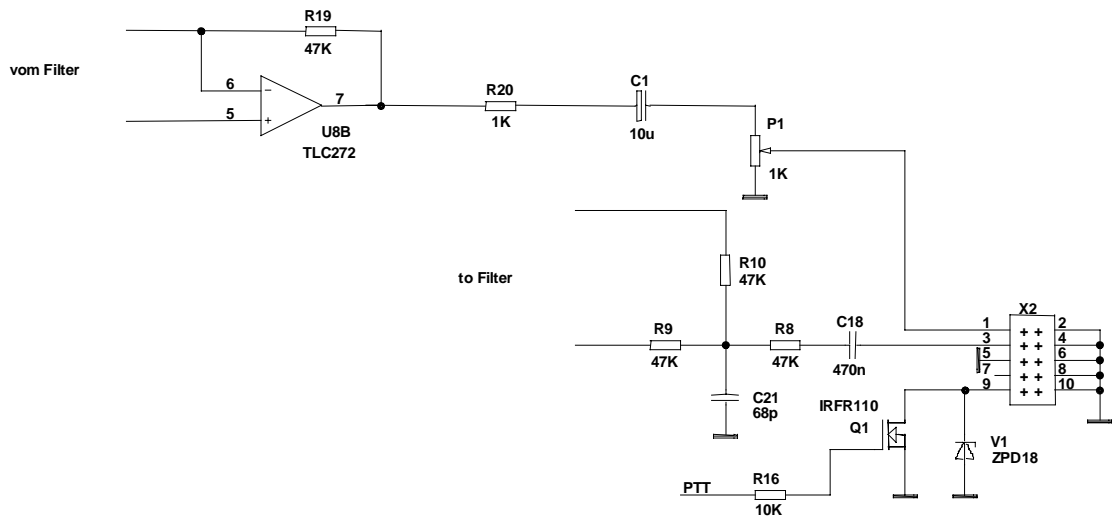

Figure C.6: Packet-Radio FSK- module

## C. Circuits

### C.7 Packet-Radio DSP-Module

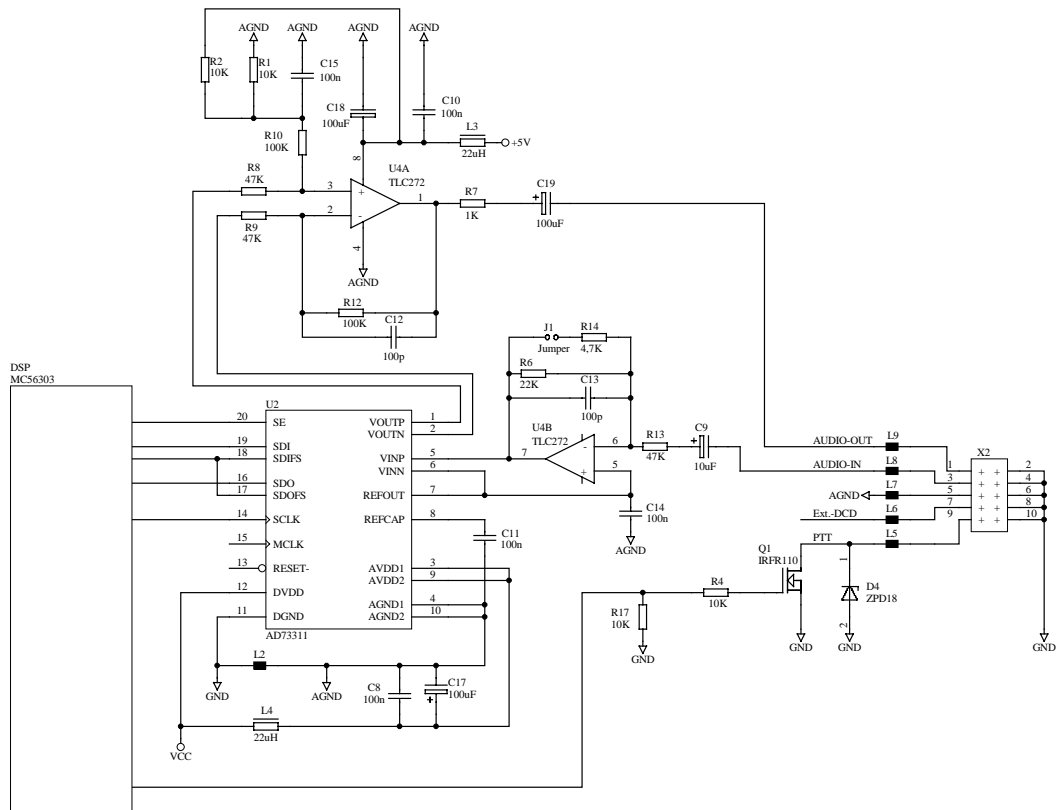

Figure C.7: DSP-Packet-Radio- module

C.8 The Y-Cable

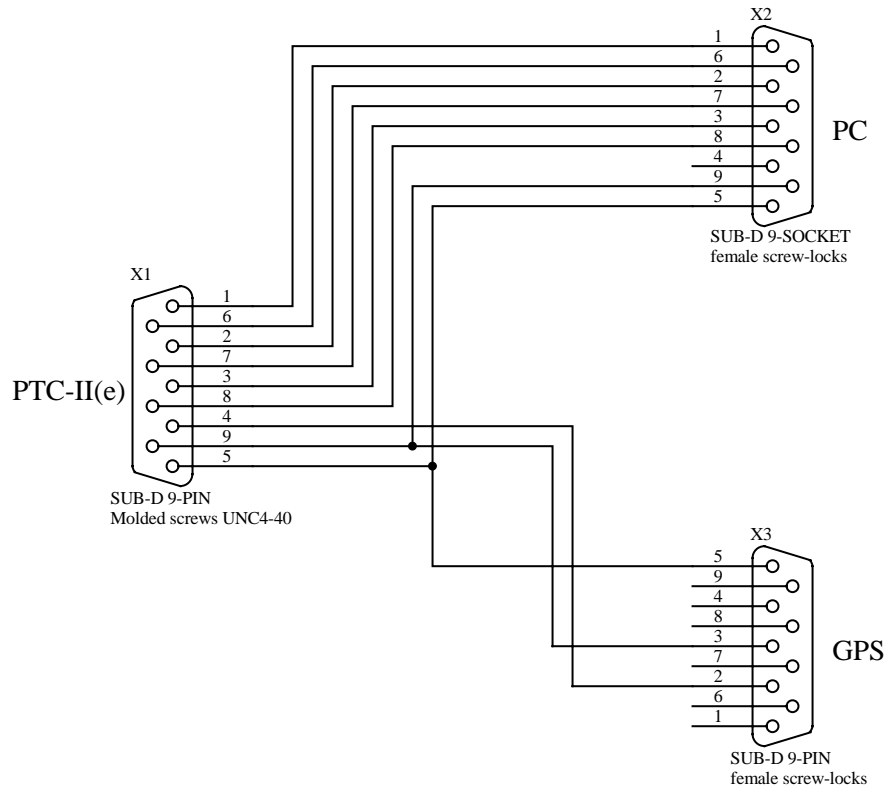

Figure C.8: The Y – cable for GPS

## Appendix D

### 22 Connector Pin-out

This Appendix shows the connector Pin-out of the PTC.  
**The view from the backside is always displayed.**

#### D.1 The power supply connector

The PTC can be powered from the coaxial low voltage socket, on the rear panel, where the center conductor is positive, the outer conductor being connected to ground. The center pin has a diameter of 2.1mm. The socket is designed for a plug with an outside diameter of 5.5 mm.

#### D.2 The 9 PIN SUB-D socket

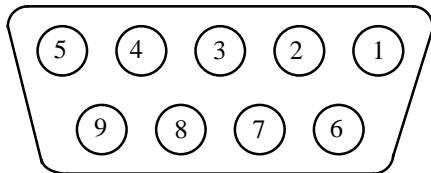

Figure D.1: RS232 Connections

- Pin 1: DCD – Output (Scan-Stop).
- Pin 2: TxD - Transmit data output. (to computer)
- Pin 3: RxD - Receive data input. (from computer)
- Pin 4: DTR - Input (RxD secondary serial port).
- Pin 5: Ground (GND).
- Pin 6: DSR - Output.
- Pin 7: CTS - Input.
- Pin 8: RTS - Output.
- Pin 9: RI - Output (TxD secondary serial port).

#### D.3 Transceiver remote-control socket

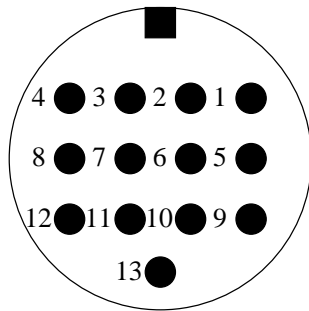

Figure D.2: Transceiver remote-control

- Pin 1:RxD TTL.
- Pin 2: RTS V24.
- Pin 3: TXD V24.
- Pin 4: CTS V24.
- Pin 5: CTS TTL.
- Pin 6: ICOM.
- Pin 7: Not connected.
- Pin 8: RxD V24.
- Pin 9: TxD TTL.
- Pin 10:RTS TTL.
- Pin 11:NF out.
- Pin 12:NF GND.
- Pin 13:GND.

**Warning: Do not interchange the TTL and V24 level connections**



## D Connector Pin-out

---

Pin	Signal	Function
1	+ 5 Volt	Power Supply of the Modems from the PTC-IIpro
3	+ 5 Volt	Power Supply of the Modems from the PTC-IIpro
5	*Reset	Reset-signal of the PTC-IIpro (e.g. for DSP-Modems)
7	*DCD	Data Carrier Detect (from the Modem to the PTC-IIpro)
9	*CTS	Transmitter is keyed (from the Modem to the PTC-IIpro)
11	*PTT	Transmitter keyed (from the PTC-IIpro to the Modem)
13	TxD	Transmission data (from the PTC-IIpro to the Modem)
15	RxD	Receiving data (from the Modem to the PTC-IIpro)
17	TxC	Transmission clock (from the Modem to the PTC-IIpro)
19	RxC	Receiving clock (from the Modem to the PTC-IIpro)
23	CFG1	Modem configuration
24	CFG2	Modem configuration
25	Clk	2,4576 Mhz Clock (e.g.: for the DSP-Modems)

Table D.1: Function of Modem signals

The name and function of the connections are only valid for external modems. For the **SCS** Packet-Radio module these connections are completely new programmed and get a totally different behavior.

The pins 21 to 26 are an extension especially used for the PTC-IIpro and must remain unused, refer to chapter [9.3](#), page [146](#).

## D Connector Pin-out

---

### D.7 Cable Color Code

#### 8-pole DIN

PIN	Color	PIN	Color
1	Violet	5	Blue
2	White	6	Red
3	Yellow	7	Black
4	Green	8	Brown

Table D.2: Cable Colors: 8-pole DIN-cable

#### 5-pole DIN

PIN	Color
1	Violet
2	White
3	Yellow
4	Green
5	Blue

Table D.3: Cable Colors: 5-pole DIN-cable

#### 8-pole Mini-DIN

PIN	Color	PIN	Color
1	Violet	5	Blue
2	White	6	Black
3	Yellow	7	Brown
4	Green	8	Red

Table D.4: Cable Colors: 8-pole Mini-DIN-cable

#### 13-pole-DIN

PIN	Color	PIN	Color
1	violet	8	red
2	white	9	pink
3	yellow	10	light blue
4	green	11	black/white
5	blue	12	grey
6	black	13	orange
7	brown		

Table D.5: Cable Colors: 13-pole -DIN-cable

## Appendix E

### 23 Glossary

#### **ADC**

Analog Digital Converter

#### **AFSK**

Audio Frequency Shift Keying

#### **AMTOR**

AMateur Teletype Over Radio – ARQ-FAX process developed out of the SITOR process by G3PLX.

#### **ANSI**

American National Standardization Institute. A Terminal-Emulation-Protocol was determined by ANSI, which has been established as a standard for mailbox systems. The ANSI-Terminal Emulation offers cursor control, color support, block graphic and generation of signal tones.

#### **ARQ**

Automatic Request. A procedure to transmit data without errors. If the transmitted data occurs with errors at the receiver, the defect information block will be called from the transceiver once again.

#### **ASCII**

American Standard Code of Information Interchange. 7-bit code for numbers, characters, special characters and control characters.

#### **Backup**

Another word for safety copies, which should be done regularly. Very special (often created with a lot of work) program configurations should be saved regularly too.

#### **Baudot Code**

5-bit code used to transmit characters in RTTY and AMTOR.

#### **BIOS**

Basic Input Output System. The BIOS contains initialization and test programs for the system start as far for the driver (relatively simple) for the peripherals.

#### **Boot**

The whole system start from switching on the system to the moment the system is ready to be used by the operator is called “Boot”.

#### **BREAKIN**

Interrupt. The current receiver is able to interrupt the transceiver and because of this forces a key transmission.

## E. Glossary

---

### **CHANGEOVER**

Key transmission from the transceiver to the receiver.

### **CPU**

Central Processing Unit.

### **CSMA**

Carrier Sense Multiple Access (to the transmission channel). A channel access process used for Packet-Radio, each station by their own has the possibility to decide if the transmission channel is free by carrier recognition.

### **DAC**

Digital Analog Converter

### **DAMA**

Demand Assigned Multiple Access. A channel access process for Packet-Radio where each station using the digipeater, the DAMA master, will be prompted definitely to transmit.

### **DSP**

Digital Signal Processor or Digital Signal Processing

### **FEC**

Forward Error Correction. Test pattern are added to the real information or the information is transmitted multiple. Because of this the receiver has the possibility to notice and correct transmission errors without transmitting the information again.

### **FIR**

Finite impulse response. Digital filter with finite impulse response.

### **Firmware**

Firmware offering necessary functions to the user, e.g. PACTOR, AMTOR, RTTY, etc. including command interpreter and multitasking. Therefore often new improved and enlarged versions are available.

### **FLASH**

Special type of ROM, which can be programmed new within the circuit.

### **FlexNet**

Software concept for digipeater which usually runs with the RMNC hardware. A time ago the FlexNet packet was transferred onto the PC hardware using the name PC-FlexNet. Further information about FlexNet and PC-FlexNet are available via Internet

<http://d10td.afthd.th-darmstadt.de/~flexnet/index.html>

### **FSK**

Frequency Shift Keying

## E. Glossary

---

### **GPS**

Global Positioning System

### **Hot-key**

The hot-key is a key or a key combination a reaction of the system follows immediately.

### **Idle**

Transmission of idle characters to keep the connection alive.

### **ISI**

Inter Symbol Interference. Interference of information symbols caused by distortions at the channel.

### **ISR**

Information Receiving Station. The current information receiver.

### **ISS**

Information Sending Station. The current information transceiver.

### **NRZ**

Non Return to Zero.

### **NRZI**

Non Return to Zero Inverse.

### **Prompt**

The input request. The prompt indicates the readiness of the system to receive commands. The PTC-IIpro indicates e.g. the readiness with **cmd:**. TNCs using **TheFirmware** will display only an asterisk \* as a prompt. Using DOS for example the prompt looks like: **C:\DOS>**.

### **PSK**

Phase Shift Keying

### **RAM**

Random Access memory

### **RMNC**

The short expression for Rhein-Main-Network-Controller. A special hardware especially developed for the use as a digipeater.

### **ROM**

Read Only Memory. In the **SCS** PTC-IIpro a special form of the ROM is used, the so called FLASH-memory.

## E. Glossary

---

### **RS232**

Standard for the transmission of serial data. Defines the pin-out of the connectors and the voltage levels.

### **RS232 level**

The voltage level of a serial interface in accordance with RS232 standard is defined as follows: -3 to -15 V for a logical 1, and +3 to +15 V for a logical 0. The range between -3 V and +3 V is not defined.

### **RTTY**

Radio Tele TYpe.

### **Rx**

Receive. Short name for receive.

### **RxD**

Receive data. Short name for receiving data.

### **SNR**

Signal Noise Ratio.

### **TAPR**

Short name for the Tucson Amateur Packet-Radio Corporation located in Tucson/Arizona (USA). The TAPR group was most responsible for the outline for the AX.25 protocol for Packet-Radio and developed the first TNC (about 1983) and the following standards like TNC2 (about 1985). Further information about TAPR are available via Internet: <http://www.tapr.org>

### **Terminal**

Simple input/output device of the early beginning of the computer area. A terminal offers a serial interface, a screen and a keyboard. All signals received by the serial interface are displayed on the screen. All inputs made at the keyboard are transmitted via the serial interface.

### **TTL**

Transceiver Transistor Logic. Integrated circuits completely built up using transistors.

### **TTL-level**

Logic level used in TTL circuits. Usually 0V for a logical 0 (low), and +5 V for a logical 1 (high) are used.

### **Tx**

Short name for transmit.

### **TxD**

Short name for transmit data.

## E. Glossary

---

### **Version number**

Each *device* has its own version number. The BIOS, the Firmware, PlusTerm, PTCFAX, the manual and the other system utilities. Perhaps you will ask why, because you are confused about the many version numbers. But it is easy to understand: Without these numbers how would it be possible to differentiate between old and new versions of the single parts?

## Applicable Literature

---

## Applicable Literature

- [1] DON MOE, KE6MN / DJ0HC: *PACTOR*. QEX, 10, 1991. CQ DL Artikel [1] und [2] in Englisch.
- [2] DR. TOM RINK, DL2FAK: *PTCplus*. RTTY Digital Journal, 2, 1994.
- [3] DR. TOM RINK, DL2FAK: *PACTOR*. Digital Journal, 6, 1994.
- [4] DR. TOM RINK, DL2FAK and HANS-PETER HELFERT, DL6MAA : *PACTOR-II - Part I*. Digital Journal, 1, 1995.
- [5] DR. TOM RINK, DL2FAK and HANS-PETER HELFERT, DL6MAA : *PACTOR-II – Part II* Digital Journal, 2, 1995.
- [6] DR. TOM RINK, DL2FAK and HANS-PETER HELFERT, DL6MAA : *PACTOR-II – Part III* Digital Journal, 3, 1995.
- [7] DR. TOM RINK, DL2FAK and HANS-PETER HELFERT, DL6MAA : *PACTOR-II – Part IV* Digital Journal, 4, 1995.
- [8] A. WALLACE, ZL1AMW: *A new digital mode PACTOR*. Break In, January/February, 1992.
- [9] ROY PHILPOT, DJ0OW: *PACTOR...Here and Now*. Amateur Radio, 12, 1992.
- [10] C. RICHARDS, 9M2CR: *PACTOR-The Magic Successor to RTTY and AMTOR*. Amateur Radio, 3, 1993.
- [11] ROY PHILPOT, DJ0OW: *PACTOR*. The Canadian Amateur Radio Magazine, 1992.
- [12] JA5TX: *PACTOR*. CQ ham radio, 10, 1992.
- [13] JA1GGA: *PACTOR PTC*. CQ ham radio, 2, 1993.
- [14] J. MEHAFFEY, K4IHP: *PACTOR Phone Home*. QST, 9, 1993.
- [15] STEVE FORD, WB8IMY: **SCS** *PTC-IIpro Multimode Controller with PACTOR-II*. QST, 1, 1997.
- [16] STAN HORZEPA, W1LOU: *Do You Need PACTOR-II, Too?* QST, 12, 1996.
- [17] VARIOUS: *A Comparison Of HF Digital Protocols*. QST, 7, 1996.
- [18] CHRIS LOREK, G4HCL: *PTC-2 Communications Controller*. HAM RADIO TODAY, 9, 1995.
- [19] DENIS BONOMO, F6GKQ: **SCS** *PTC-IIpro: controleur PACTOR multimodes*. MEGAHERTZ magazine, 4, 1997.
- [20] BUCK ROGERS, K4ABT: *PACTOR: la nueva frontera*. Radio Amateur, 12, 1993.

## Applicable Literature

---

<b>Index</b>	
<p><b>%</b></p> <p>%B ..... 177</p> <p>%C ..... 178</p> <p>%E ..... 178</p> <p>%F ..... 178</p> <p>%I ..... 178</p> <p>%L ..... 179</p> <p>%M ..... 179</p> <p>%O ..... 179</p> <p>%P ..... 180</p> <p>%T ..... 180</p> <p>%V ..... 180</p> <p>%W ..... 180</p> <p><b>@</b></p> <p>@B ..... 175</p> <p>@D ..... 175</p> <p>@F ..... 175</p> <p>@S ..... 177</p> <p>@T2 ..... 177</p> <p>@T3 ..... 177</p> <p><b>1</b></p> <p>13-pol-DIN ..... 260</p> <p><b>5</b></p> <p>5-pol DIN ..... 260</p> <p><b>8</b></p> <p>8 pole DIN socket ..... 258</p> <p>8-pol DIN ..... 260</p> <p>8-pol Mini-DIN ..... 260</p> <p><b>9</b></p> <p>9 pin SUB-D socket ..... 257</p> <p><b>A</b></p> <p>About this manual ..... 1</p> <p>Accessories ..... 241</p> <p>ACheck (AMTOR Check) ..... 61</p> <p>ADdlf ..... 61</p> <p>AGain ..... 135</p> <p>Alias ..... 161</p> <p>Amfax ..... 129</p> <p>AM-FAX ..... 123</p>	<p>Amplitude Settings ..... 17</p> <p>AMTEX ..... 48, 93</p> <p>Amtor ..... 61</p> <p>AMTOR ..... 71</p> <p>AMTOR listen ..... 90</p> <p>Antenna-switch ..... 211</p> <p>APower ..... 62</p> <p>APRS ..... 50, 150</p> <p>APRS Comment ..... 151</p> <p>APRS Path ..... 151</p> <p>APRS Position ..... 152</p> <p>APRS Short ..... 152</p> <p>APRS Symbol ..... 152</p> <p>APRS Timer ..... 153</p> <p>AQrg ..... 63</p> <p>AResolut ..... 136</p> <p>ARX ..... 64, 66</p> <p>Audio ..... 119, 195</p> <p>AUdio ..... 64</p> <p>Audio functions ..... 57</p> <p>Audio output level ..... 81, 97</p> <p>AUDPerm ..... 195</p> <p>Auto status in hostmode ..... 183</p> <p>Avoid incompatibility ..... 56</p> <p><b>B</b></p> <p>BAKup ..... 64</p> <p>Bandwidth ..... 119</p> <p>Basic principles ..... 185</p> <p>Basics of the PACTOR-II protocol ... 231</p> <p>Battery ..... 196</p> <p>BATtery ..... 219</p> <p>Baud ..... 154</p> <p>BAUdot ..... 65</p> <p>Baudrate ..... 101</p> <p>BC ..... 66</p> <p>Beep ..... 196, 219</p> <p>BEll ..... 66</p> <p>BIOS ..... 215</p> <p>BIOS activating ..... 216</p> <p>BIOS and Firmware ..... 215</p> <p>BKchr ..... 66</p> <p>BMsg ..... 67</p> <p>BOOT ..... 67</p> <p>Box ..... 67</p> <p>Breakin ..... 76</p> <p>BRightn ..... 68</p>

## Index

<b>C</b>		
C .....	170	
Callsign .....	162	
CBell .....	155	
Center .....	119	
CFg .....	219	
CHANGEOVER problems .....	54	
Channel .....	199	
CHeck .....	68, 155	
CHKFlash .....	219	
CHKRam .....	219	
CHOBell .....	68	
CHOchr .....	69	
CLr .....	69, 219, 220	
CMsg .....	69, 155	
Command structure .....	38	
Commands .....	169	
Comparator .....	133	
COMPARATOR-MODEM .....	129	
Connect .....	155, 170	
Connect message .....	155	
Connections to the transceiver .....	12	
Connect-text .....	156	
CONStamp .....	156	
Contact <b>SCS</b> .....	9	
CONVerse .....	156	
CQ Calls and broadcasts .....	239	
CRC hostmode in detail .....	184	
CSDelay .....	73	
CStatus .....	156	
CText .....	156	
CTExt .....	73	
CTrlchr .....	74	
CWfilter .....	119	
CWid .....	74	
CWMoni .....	75	
CWSpeed .....	75	
CWTerm .....	75	
CWWeight .....	77	
CYcle .....	78	
<b>D</b>		
D .....	171	
DAMA .....	143, 169	
Data transparency .....	55	
DAtc .....	78, 216	
DD .....	78, 120, 196, 200	
Delay .....	120	
DELeTe .....	78	
Deviation .....	137	
DIGIpeat .....	157	
DIR .....	79	
Disconnect .....	78, 80, 99, 157, 171	
Display and indicator unit .....	226	
Displayboard .....	248	
Down .....	201	
DSP Packet-module .....	25	
DUmp .....	201	
Duplex in PACTOR .....	56	
DWell .....	203	
<b>E</b>		
EQualize .....	80	
Error control coding .....	235	
ESCchr .....	80	
Extended Hostmode .....	182	
External modems .....	147	
<b>F</b>		
F .....	171	
FAX .....	80, 81, 123, 175	
FAX and SSTV basics .....	123	
Fax menu command .....	128	
FCall .....	217	
FEc .....	81	
FEC .....	66	
Firmware of the PTC-IIpro .....	37	
Firmware update .....	114	
FlexNet-Gateway .....	72	
Fmfax .....	130	
FM-FAX .....	124	
Frack .....	171	
FRack .....	157	
Frequency .....	203	
FResolut .....	136	
FSelcall .....	217	
FSK .....	132, 196	
FSKAmpl .....	81	
FSKBaud .....	137	
FSKFilter .....	158	
Fulldup .....	158	
<b>G</b>		
Gate .....	82	
Gate command .....	52	
Gateway PR → PACTOR .....	51	
General Information .....	123	

## Index

- General points ..... 237  
Glossary ..... 261  
GPS ..... 49, 97, 173  
    connect a receiver ..... 49  
    NMEA ..... 49  
    POSition command ..... 49  
    Y-cable ..... 49, 241
- H**
- HCr ..... 83  
Help ..... 83, 120, 158, 196, 204, 217, 219  
HF modem with signal processor ..... 223  
HF-Transceiver Audio ..... 253  
HF-Transceiver Control ..... 253  
High tones ..... 111  
Hostmode ..... 58, 159, 167  
How it all began ..... 243  
HSynch ..... 137
- I**
- I ..... 171  
ICOM connection ..... 21  
IF-SHIFT ..... 141  
Installation ..... 11  
Invert ..... 120, 121
- J**
- JHOST ..... 159, 172  
JSynch ..... 138  
JVComm ..... 132  
JVComm32 ..... 126  
Jvfax ..... 131, 132
- K**
- K ..... 172  
KENWOOD TTL connection ..... 20  
KENWOOD V24 connection ..... 20  
Kill ..... 197
- L**
- L ..... 172  
Led ..... 197  
LED description ..... 33  
LED functions and the matrix-display  
    ..... 140  
LED functions with FAX ..... 127  
LED's in PR300 operation ..... 141  
LEDs whilst receiving ..... 140  
LEDs whilst transmitting ..... 140
- LFignore ..... 83  
LIN ..... 84  
List ..... 204  
List ..... 84  
Listen mode ..... 85, 160  
LOCK ..... 86  
Logbook ..... 86  
LOGIn ..... 86  
Longpath connect ..... 70  
Low tones ..... 111
- M**
- M ..... 172  
MAil ..... 87  
Mail announcement ..... 87  
Mailbox ..... 40, 67  
    command properties ..... 45  
    commands ..... 41  
    file operations ..... 42  
    Packet-Radio ..... 42, 43, 163  
    passing PR to ..... 45  
    read ..... 99  
    reading files ..... 42  
    reload ..... 100  
Mainboard ..... 249  
MARK ..... 87  
MASTER protocol ..... 186  
Matrix Display ..... 140  
MAXDown ..... 87  
MAXErr ..... 88  
MAXframe ..... 159  
MAXSum ..... 88  
MAXTry ..... 88  
MAXUp ..... 89  
MBaud ..... 137  
MCon ..... 159  
Menus ..... 38, 39  
MFilter ..... 159  
MOde ..... 89  
Modern Times ..... 150, 168  
Modulation system ..... 232  
Monitor ..... 160  
MONitor ..... 90, 197  
MStamp ..... 160  
MText ..... 161  
MYAlias ..... 161  
MYcall ..... 90, 162  
MYLevel ..... 91  
MYMail ..... 162  
MYSelc ..... 91

## Index

- N**
- N .....173
  - NAVTEX .....91
  - NAVTEX area code .....92
  - NAVTEX details .....46
  - NAVTEX general .....45
  - NAVTEX in practice .....48
  - NAVTEX latency .....93
  - NMEA .....49, 97, 173
  - NMEA channel .....184
  - Notch .....120
  - NULI .....94, 95, 217
- O**
- O .....173
  - Offset .....204
  - Online data compression .....236
- P**
- P .....173
  - PACket .....95
  - Packet-Radio .....143
    - 300 baud via HF .....133
    - Enabling the mailbox .....163
    - Hostmode .....167
    - Installing the modules .....23
    - Internal modem interface .....258
    - Listen mode .....160
    - PR → PACTOR Gateway .....51
    - The AFSK-module .....28, 247, 254
    - The connectors .....31, 258
    - The DSP-module .....25, 143, 248
    - The FSK-module .....29, 247, 254
    - The modules .....23, 143, 226
  - PACLen .....162
  - PACTOR data transparency .....57
  - PACTOR-II in practice .....237
  - Parameter Commands .....135
  - Parity .....205
  - PDTimer .....96
  - PDuplex .....96
  - Peak .....121
  - PErsist .....162
  - Phase .....96
  - PLI .....197
  - Port .....163
  - Port & Channel .....149
  - POSition command .....97, 173
  - Power supply .....11, 225
  - Power supply connector .....257
  - Processor section .....221
  - PSK31
    - Activating the terminal .....191
    - Carrier Frequencies .....192
    - CW-Identification .....194
    - Hot-keys .....194
    - In general .....191
    - Level Setting .....192
    - Prompt and Status .....192
    - Receiver Tuning .....194
  - PSKAmpl .....98
  - PSKTerm .....98
  - PT .....98
  - PTChn .....98
  - PTC-IIpro construction .....226
  - Ptime .....205
  - Ptt .....197
- Q**
- Qrt .....98
  - QRTChr .....99
  - Quit .....121, 163, 198, 205, 220
- R**
- Ram .....198
  - Read .....99
  - Recommended baudrate .....188
  - RELOad .....100
  - REMote .....100
  - Remote commands .....39
  - Repair .....10
  - Requirements .....1
  - Reset .....100, 101
  - RESptime .....163
  - REStart .....10, 101
  - REtry .....163
  - RLe .....101
  - Robust connect .....70
  - Robust HF-Packet .....50
  - RS232 Interface .....252
  - RTCTrim .....220
  - RTTY .....65
  - RTTY squelch .....103
  - RType .....205
  - RUN .....220
- S**
- Scan .....206
  - Scan stop signal .....210
  - SCS**-PTC the original .....1

## Index

- Send ..... 101  
SERBaud ..... 101, 218  
Serial interface (RS232/V24) ..... 11  
SERNum ..... 198  
Setchn ..... 164  
SFile ..... 102  
SHow ..... 102  
Simultaneous STBY mode ..... 39  
Sinewave generator ..... 121  
SLAVE-protocol ..... 186  
SLOttime ..... 164  
SMode ..... 139  
SPAcE ..... 103  
Speed and robustness ..... 238  
SQuelch ..... 103, 104  
SResolut ..... 136  
SSTV ..... 125, 126, 130  
Start of the CRC-hostmode ..... 187  
SStatus ..... 104, 106  
Status output in hostmode ..... 182  
Stuffing errors ..... 187  
SYStest ..... 106, 195, 218
- T**
- T ..... 173  
Technical Data ..... 245  
Term ..... 107  
Through ..... 121  
TIme ..... 109, 218  
Timeout ..... 88  
TImer ..... 206  
Tips and Tricks ..... 141  
TNC ..... 109  
TOne ..... 121  
TOnes ..... 110  
TR ..... 112  
TRACE ..... 164  
Transceiver control ..... 18, 112, 199  
Transceiver remote-control socket .... 257  
Transfer ..... 207  
Transmission at Modem operation .... 134  
Transmit in AM-FAX ..... 134  
Transmit in COMPARATOR mode.. 135  
Transmit in FM-FAX/FSK/SSTV ..... 134  
TRX ..... 112, 199  
TRX command ..... 52  
TRX frequency list ..... 52  
Trxtest ..... 220  
Tuning indicator and behavior ..... 238
- Tuning indicator and LED display .... 140  
Tuning with SSTV ..... 141  
TXcomp ..... 139  
TXdelay ..... 164  
TXDelay ..... 112  
TXLevel ..... 165  
TYpe ..... 207, 208  
Typography ..... 2
- U**
- U ..... 174  
Umlauts ..... 113  
Unproto ..... 113, 166  
Up ..... 208  
UPDATE ..... 114, 219  
USer ..... 115  
USers ..... 166  
USOs (Unshift On Space) ..... 115
- V**
- VERIfy ..... 115  
Version ..... 115, 219  
Version numbering ..... 5
- W**
- W ..... 174  
Wait ..... 209  
Why PACTOR? ..... 229  
Why PACTOR-II ? ..... 230  
Write ..... 116
- X**
- XGate ..... 209  
XScan ..... 209  
XUser ..... 116
- Y**
- Y ..... 175  
YAESU 757 connection ..... 21  
YAESU connection ..... 21  
YAESU Transceiver control ..... 210  
YAESU V24 connection ..... 21  
Y-cable ..... 256  
YType ..... 210